

Oct. 31, 1967

E. J. MOYER ET AL

3,349,934

BELT EJECTOR BUCKET AND CONTROL LINKAGE THEREFOR

Filed April 26, 1966

4 Sheets-Sheet 1

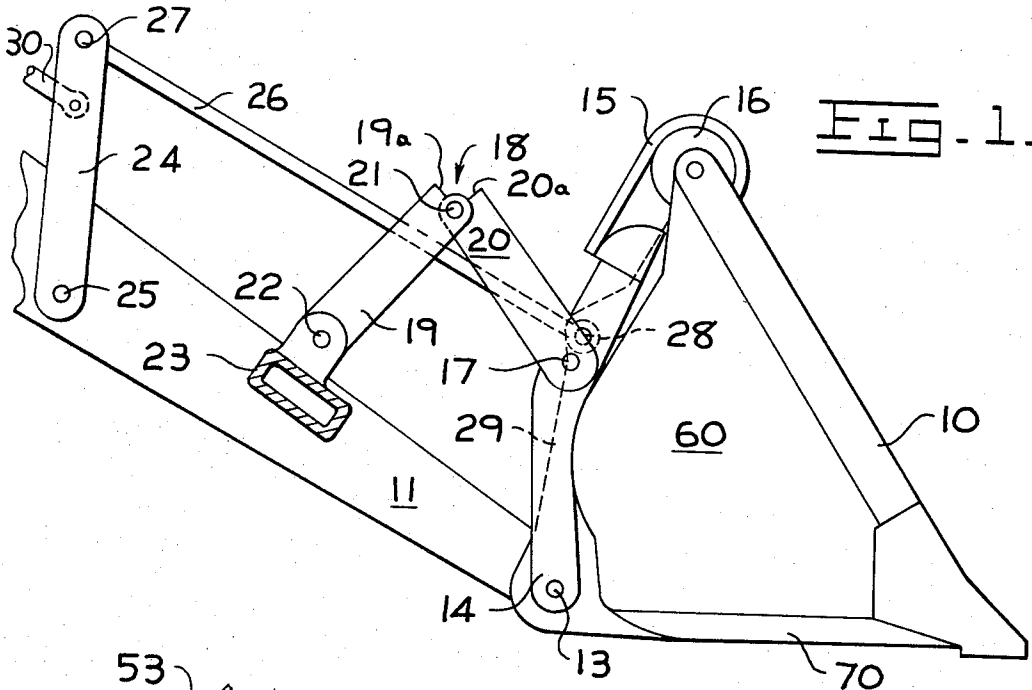

FIG. 1.

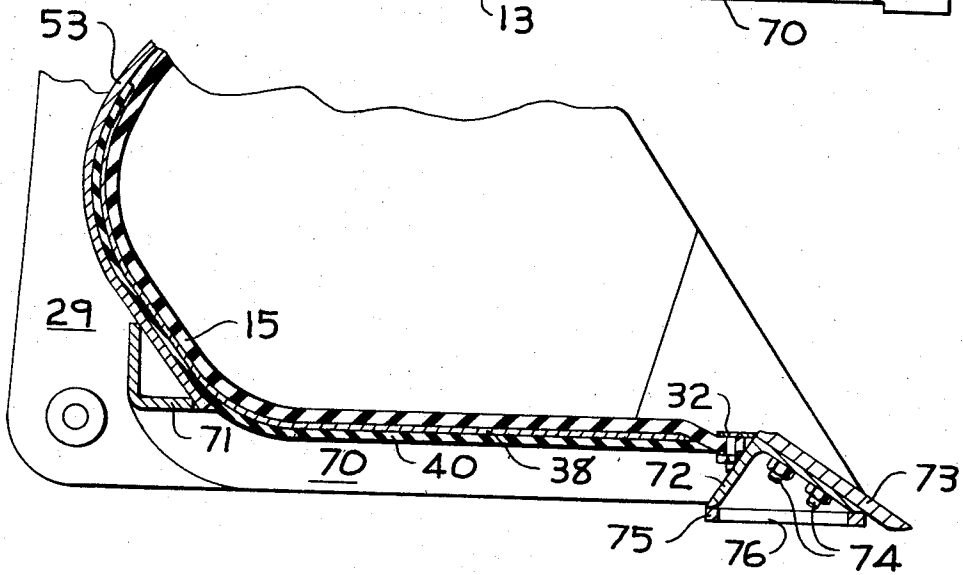

FIG. 2.

INVENTORS
EDWARD J. MOYER
ROBERT J. SULLIVAN
BY *Fryer, Zimmervoll, First & Phillips*
ATTORNEYS

Oct. 31, 1967

E. J. MOYER ETAL

3,349,934

BELT EJECTOR BUCKET AND CONTROL LINKAGE THEREFOR

Filed April 26, 1966

4 Sheets-Sheet 2

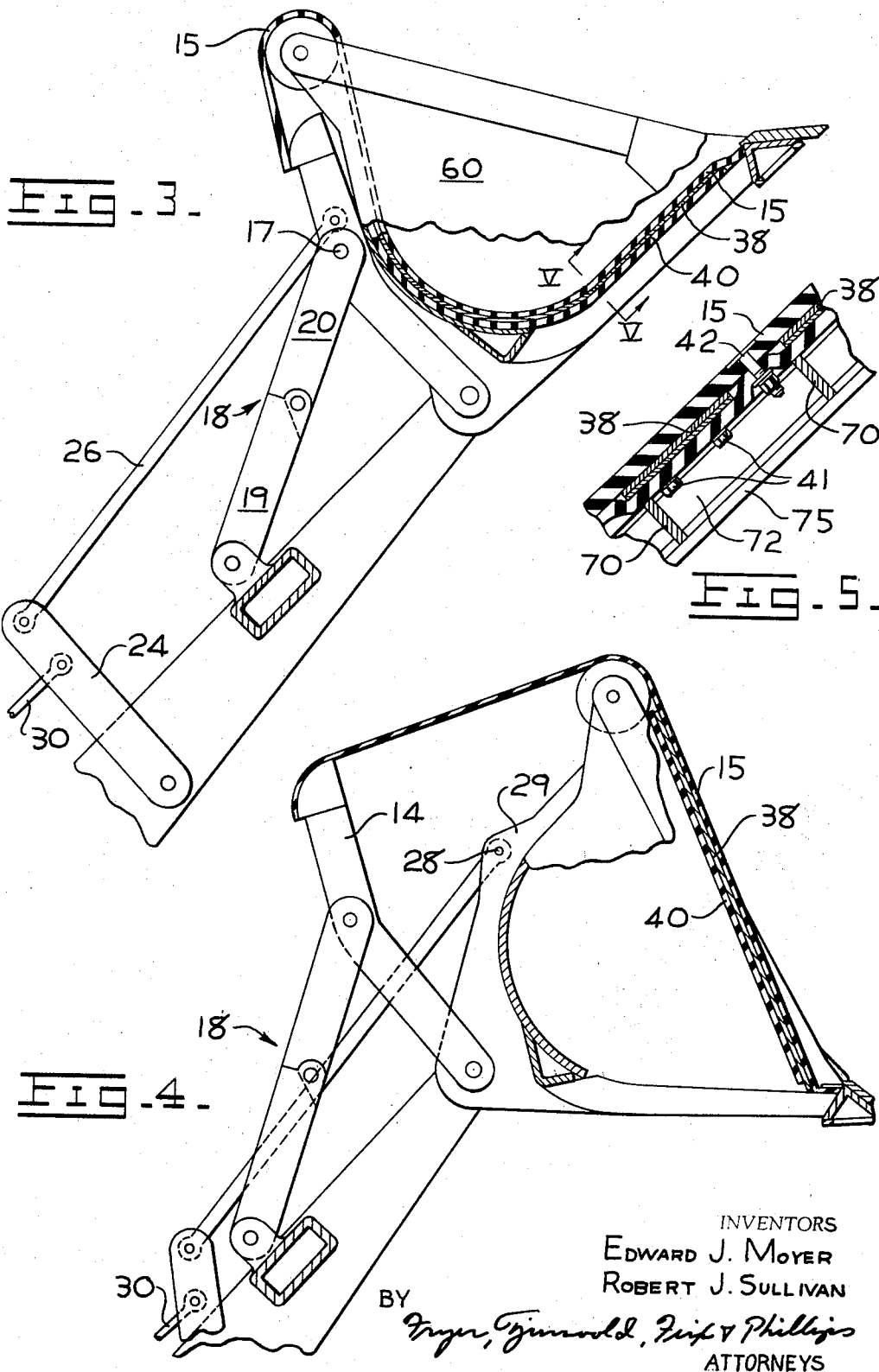

INVENTORS
EDWARD J. MOYER
ROBERT J. SULLIVAN
BY *Myer, Ginnwood, Zeit & Phillips*
ATTORNEYS

Oct. 31, 1967

E. J. MOYER ET AL

3,349,934

BELT EJECTOR BUCKET AND CONTROL LINKAGE THEREFOR

Filed April 26, 1966

4 Sheets-Sheet 3

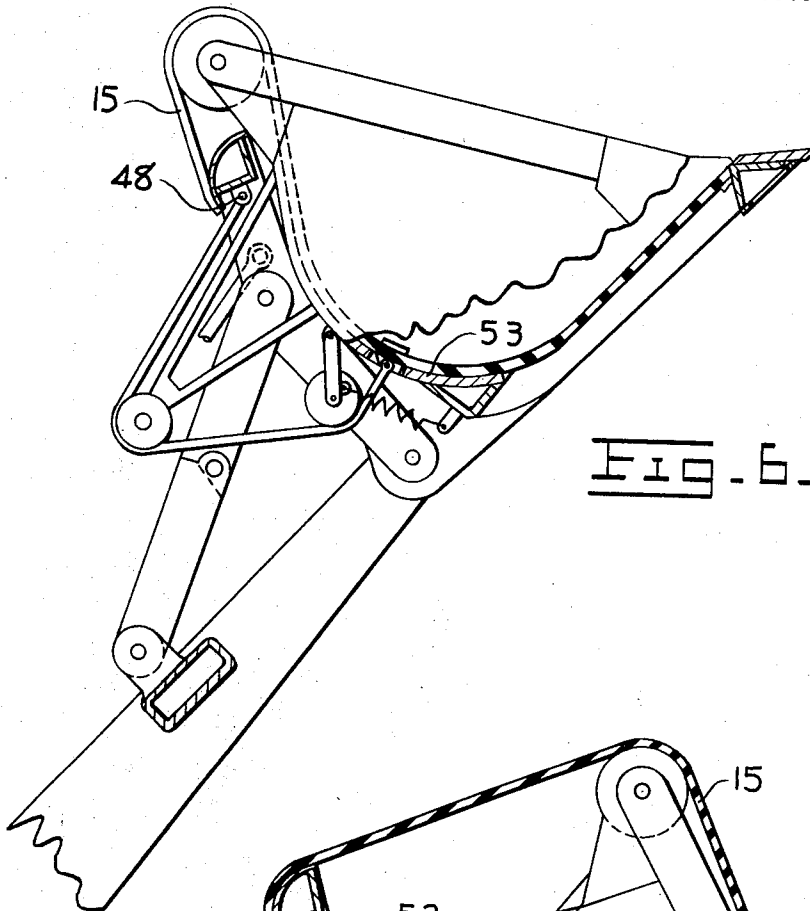

FIG. 6.

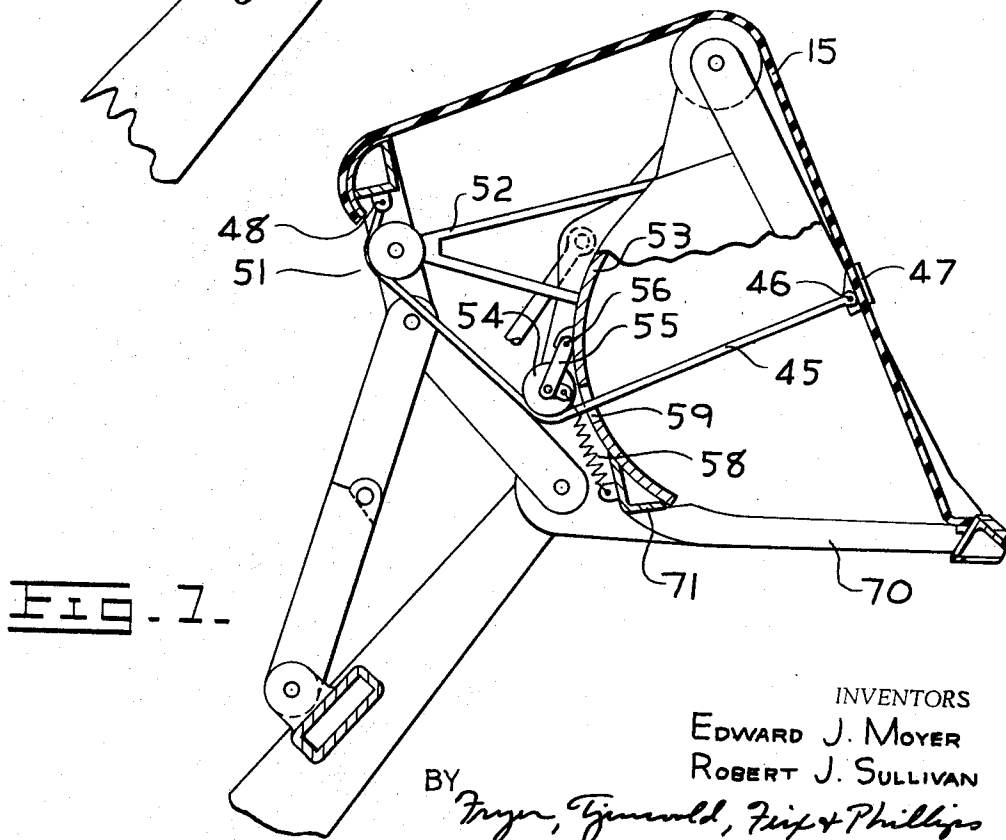

FIG. 7.

INVENTORS
EDWARD J. MOYER
ROBERT J. SULLIVAN
BY *Fryer, General, Fitz & Phillips*
ATTORNEYS

Oct. 31, 1967

E. J. MOYER ETAL

3,349,934

BELT EJECTOR BUCKET AND CONTROL LINKAGE THEREFOR

Filed April 26, 1966

4 Sheets-Sheet 4

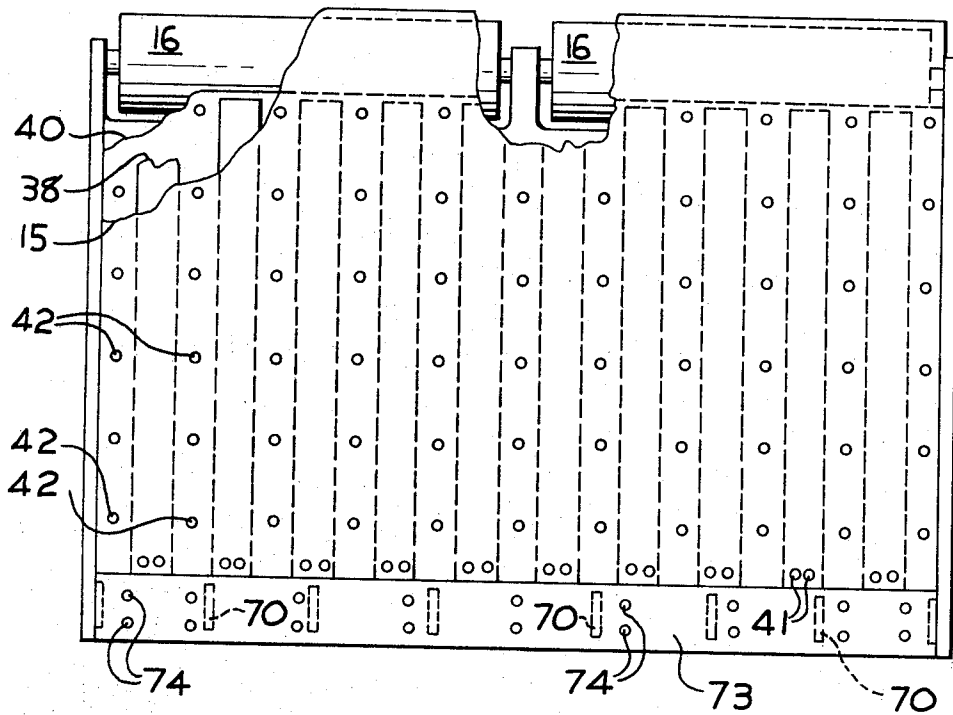

Fig. 9.

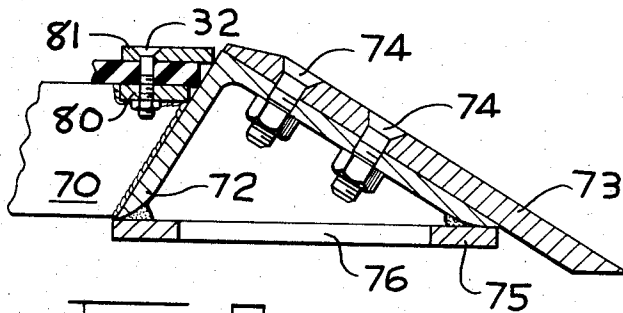

Fig. 8.

INVENTORS

EDWARD J. MOYER

ROBERT J. SULLIVAN

BY

Fryer, Gemmald, Fink & Phillips

ATTORNEYS

1

2

3,349,934

BELT EJECTOR BUCKET AND CONTROL LINKAGE THEREFOR

Edward J. Moyer, Morton, and Robert J. Sullivan, Peoria, Ill., assignors to Caterpillar Tractor Co., Peoria, Ill., a corporation of California

Filed Apr. 26, 1966, Ser. No. 545,334

7 Claims. (Cl. 214-767)

ABSTRACT OF THE DISCLOSURE

A plurality of spring leaves, having an inherent tendency to assume the shape of the back and bottom of the interior of the bucket, is sandwiched between an ejector belt and a backing belt, the combination of which is secured at one of its ends adjacent the lower lip of the bucket. As the bucket is returned to its loading position by conventional linkage, control linkage, disposed to control the movement of a pair of ejector legs secured to the other end of the ejector belt in the combination, no longer prevents the ejector legs from allowing the ejector belt to assume a relaxed ejector belt position. The tension in the combination being relaxed, the ejector belt is automatically returned to the interior of the bucket under the influence of the residual spring force of the spring leaves.

This invention relates to loader buckets and more particularly to an improved loader bucket which has an ejector belt for automatically ejecting loads which by their nature tend to adhere to the inside of the bucket, and in control linkages associated therewith.

Reference is made to the disclosure in assignee's U.S. Patent No. 3,035,724 entitled "Ejector for Loader Buckets" where a bucket of the kind to which the present invention relates is described as being pivotally mounted at the end of elevatable lift arms pivotally mounted to a tractor loader. The present invention is directed to improvements in the construction of this type of bucket and control linkage associated therewith.

It is an object of the present invention to provide a loader bucket which has improved material handling and automatic load ejecting reliability and efficiency.

It is also an object of the present invention to provide an improved automatic load ejecting bucket having an improved bucket control linkage.

Further and more specific objects and advantages of the present invention are made apparent in the following specification wherein reference is made to the accompanying drawings.

In the drawings:

FIG. 1 is a side elevation of one embodiment of the improved loader bucket and control linkage of the present invention;

FIG. 2 is a fragmentary sectional side elevational view of the bucket of FIG. 1;

FIG. 3 is a side elevation, partly in section, of the embodiment of the bucket and linkage of FIG. 1 in its raised and racked-back carrying position;

FIG. 4 is a view similar to FIG. 3 illustrating the bucket and linkage in its dumping or automatically load ejecting condition;

FIG. 5 is an enlarged fragmentary section taken on the line V-V of FIG. 3;

FIG. 6 is a side elevation, partly in section, and with parts broken away of a modification of the bucket and linkage of the present invention in its raised and racked-back carrying position;

FIG. 7 is a view similar to that in FIG. 6 showing the bucket in its dumping position;

FIG. 8 is an enlarged cross-sectional view of the cutting edge assembly of the bucket; and

FIG. 9 is a front elevation of the bucket of FIG. 4 partly in section and with portions broken away.

Referring to FIGS. 1, 2, 3 and 4, one embodiment of the improved bucket 10 of the present invention is shown pivotally mounted as at 13 to the forward end of one of two lift arms 11 which are pivotally mounted in a conventional manner to a tractor loader or to a similar earth moving unit (not shown). The lower end of an ejector belt control leg 14 is also pivotally mounted to the bucket as at 13, and the upper end of the leg is fixedly connected to one end of an ejector belt 15 trained over rollers 16 journaled at the top of the bucket. The other end of the ejector belt is fixedly connected adjacent the lower forward edge of the bucket as by bolts 32. The mid portion of the ejector leg is pivotally attached as at 17, to one end of control link 18 which consists of two links 19 and 20 pivotally connected to each other as at 21. Ends 19a and 20a abut when the control link is in its extended position as shown in FIG. 3. Link 19 is pivotally mounted as at 22 to a lift arm bracket 23.

Lever 24 of conventional bucket tilt linkage (not shown) is pivoted to the lift arm as at 25. The lever pivotally supports one end of a link 26 as at 27. The other end of this link is pivoted as at 28 to a back bucket support 29. The lever 24 is adapted to be rocket in a conventional manner by link 30, only a portion of which is shown.

After the bucket has been filled and raised by means of the lift arms 11 and lift jacks (not shown) from the loading position of FIG. 1 to the position illustrated in FIG. 3, forward movement of link 30 by tilt jacks (not shown) will cause lever 24 and link 26 to pivot the bucket to its dumping position illustrated in FIG. 4. As the bucket pivots to its dumping position, the belt becomes taut and automatically ejects the load from the interior of the bucket. Since control link 18 limits the clockwise movement of the ejector leg, the fixed ends of the ejector belt assure that it will become taut and that the load will be automatically ejected as the bucket is pivoted to its dumping position.

Referring next to the ejector belt, its improved construction assures that it will consistently tend to return inwardly and to line the back and bottom interior of the bucket once the load has been ejected and the bucket is racked back from its dumping position. In the embodiment illustrated in FIGS. 1, 2, 3, 4, 5 and 9, the belt is shown backed with leaf springs 38 which in turn are backed by a thin backing belt 40. In FIG. 5, the leaf springs are illustrated in layered pairs sandwiched between the ejector belt and thin backing belt. The leaf springs are formed to the shape of the interior of the bucket and, therefore, have a residual tendency to withdraw the composite belt into the interior of the bucket. The ends of the springs adjacent the cutting edge 73 of the bucket are bolted between the belt and the backing belt as by bolts 41 and the other ends of the springs are free to have relative movement with respect to the inner and outer belts in between the parallel paths formed by bolts 42.

As illustrated in FIG. 9 when the bucket is in its automatically ejecting position, the free ends of the ten pairs of leaf springs have extended in between these parallel paths to a position adjacent rollers 16.

A second embodiment of the invention which assures that the ejector belt will return to the interior of the bucket after its load has been ejected is illustrated in FIGS. 6 and 7. In this embodiment, one end of a cable 45 is pivotally attached as at 46 to an element 47 permanently affixed to a single ejector belt 15 at a location approximately one-third of its length. The other end of the

cable is pivotally connected as at 48 to the free end of the ejector leg. The cable is trained over pulley 51 journalled to bracket 52 fixedly attached to the back shell 53 of the bucket and is also trained over pulley 54 journalled to arm 55 pivotally mounted as at 56 to the back shell of the bucket. Pulley 54 is spring loaded as by spring 58 one end of which is attached to a transverse support member 71.

It will be seen that as the bucket is rocked in the manner previously explained from its raised and racked back carrying position as illustrated in FIG. 6 to its dumping and automatically ejecting position of FIG. 7, the cable is pulled through hole 59 in the bucket shell by element 47 on the belt. As the bucket is racked back from its dumping position, pulley 51 is forced in a counter-clockwise direction. Since pulley 51 rides on the cable, it urges the cable rearwardly which in turn pulls the belt inwardly.

In both embodiments of the ejector bucket of the present invention, the bottom of the bucket is formed from a number of parallel ribs 70 welded at their back ends to a transverse support member 71 (see FIG. 2) which in turn is welded to back shell 53. The shell in turn is supported by back bucket support 29. The forward ends of the ribs are welded to a cutting edge support assembly which consists of an angle member 72 to which a cutting edge 73 is bolted as by bolts 74. The bottom of the angle member is closed by transverse plate 75 through which holes 76 are drilled to provide access to bolts 74. Transverse plate 75 acts as a skid shoe, stabilizes the working edge of the bucket and tends to prevent the cutting edge from burying itself as the bucket is worked into the material to be loaded.

Referring to FIG. 8, transverse metal strips 80 are welded between the longitudinally extending ribs and adjacent the rear of angle member 72. To prevent dirt from accumulating between the angle member and the end of the belt and thereby to prevent abrasion of this end of the belt; a second metal strip 81 is placed on top of the belt. The belt is bolted between these metal strips as by bolts 32.

It will be appreciated that since the ribs form the bottom of the bucket, they provide an open support area for the ejector belt and a means of escape for dirt which otherwise might accumulate between the ejector belt and a bucket which has a continuous bottom.

We claim:

1. In a loader bucket assembly which is pivotally mounted to the ends of a pair of elevatable lift arms and

which has ejector mechanism for automatic load dumping including a belt and a pair of ejector legs; the improvement comprising: means attached to the belt for urging it towards the interior of the bucket.

2. The improvement as defined in claim 1 further comprising lever means consisting of two interpivot links and pivotally connected to the pair of lift arms and to the pair of ejector legs and means defining a partly open bucket bottom.

3. The improvement as defined in claim 1 wherein said means attached to the belt comprises spring leaf means having an inherent tendency to assume the shape of the bottom and back of the interior of the bucket.

4. The improvement as defined in claim 3 further comprising a backing belt disposed behind and fixedly attached to the belt and sandwiching the spring leaf means therebetween.

5. The improvement as defined in claim 4 wherein the belt and backing belt are bolted together along a plurality of parallel bolt paths and wherein spring leaf means are both disposed between each of the plurality of bolt paths and secured to said belt and backing belt at one location therealong.

6. The improvement as defined in claim 1 wherein said means attached to the belt includes a cable and further comprising pulley means rigidly mounted at the rear of the bucket; wherein said cable is drawn over the pulley means through the back of the bucket and fixedly connected to both the ejector legs and to the belt and wherein progressive racking back of the bucket causes the pulley means to progressively urge the belt to return to the interior of the bucket.

7. The improvement as defined in claim 2 wherein said means attached to the belt includes a cable and further comprising pulley means rigidly mounted at the rear of the bucket; wherein said cable is drawn over the pulley means through the back of the bucket and fixedly connected to both the ejector legs and to the belt and wherein progressive racking back of the bucket causes the pulley means to progressively urge the belt to return to the interior of the bucket.

References Cited

UNITED STATES PATENTS

45 3,035,724 5/1962 Clark et al. ----- 214-767

HUGO O. SCHULZ, *Primary Examiner.*