

**This is not a peer-reviewed article.**

K. N. Brodbeck, 2004. *Choosing the Right Tire*: ASAE Distinguished Lecture # 28, pp. 1-13. Agricultural Equipment Technology Conference, 8-10 February 2004, Louisville, Kentucky USA. ASAE Publication Number 913C0204.

## Choosing the Right Tire

**Kenneth N. Brodbeck**

Manager, OE/Export Sales Engineering, Firestone Agricultural Tire Division, Des Moines, Iowa 50313  
phone: 515-242-2308; e-mail: brodbeckken@firestoneag.com

**Abstract.** *This lecture provides a short history of agricultural tractors and wheel equipment. A list of basic tire terms used to describe the tire profile is covered, along with performance criteria used to match mechanical front drive axles to the rear axle for proper gearing. In addition, the RCI table is introduced to provide a visual example of how tires can be grouped by rolling circumference and overall diameter. A description of tire size designations is listed for bias, radial, and flotation sizing. The load rating designations for ply, star, and load index is also explained. The five most common tread designs for powered axles are defined, with examples of the different patterns. Two examples of the creation of new tire sizes are given: one for large, high-horsepower, four-wheel drive tractors, and one for high-capacity row crop sprayers. Cyclical loads and their restrictions are also discussed.*

**Keywords.** *Aspect ratio, Cyclical loading, Load index, Load rating, Overall diameter, Rolling circumference, Rolling circumference index, Section height, Section width, Star rating, Static loaded ratio, Tread designations.*

Pneumatic tires have greatly improved the performance of agricultural machines since their first introduction in the 1930s. Tread designs, sizes, and uses continue to evolve with the ever-increasing size, weight, speed, and complexity of today's machines. These parameters continually challenge the tire company's ability to meet the needs of its customers.

### Tire and Tractor History

Farmers relied on horse-drawn equipment for their workload for many years. Heavier tasks were next taken over by steam-powered tractors, with some machines exceeding 150 hp and weighing over 25 tons. Steam tractors, with steel wheels with bolt-on or cast cleats, can develop high drawbar loads but have several limitations:

- They cannot be run on paved roads.
- Their ride is extremely rough.
- They cause high soil compaction.
- They have limited mobility in wet soils.

In the early 1920s, machinery companies began to manufacture tractors with internal combustion engines, but these tractors still had steel wheels and the same drawbacks for traction and mobility as steam tractors. For increased maneuverability in their orchards, Florida citrus farmers began using Goodyear aircraft tires on their orchard tractors in 1931 (Goodyear, 2003a).

In 1934, a model WC Allis-Chalmers was the first tractor to be tested with pneumatic Firestone tires at the Nebraska Tractor Test lab. The lab conducted a 4-hour economy test with both steel wheels and pneumatic tires. The steel wheels produced 5.62 horsepower hours/ gallon. The rubber tires developed 8.18 horsepower hours/

gallon, a 45% fuel economy advantage over steel wheels. This is even more impressive when one realizes that both tests were conducted on soil (Wendel, 1985).

In the early 1930s, tire companies began to offer pneumatic tires for farm tractors. By 1939, 85% of the original equipment manufacturers (OEMs) tractors came with rubber tires rather than steel (Lief, 1951). The earlier aircraft tires evolved into 45° bar bias-ply tires and into today's modern radial designs.

### Tire Terminology

Refer to figures 1 and 2 for illustration of the following terms:

- Section height is the design height of a tire section measured from the base of the tire bead to the top of the tread.
- Section width is the width of a new tire, including 24-hour inflation growth and normal sidewalls, but not including protective side ribs, bars, or decorations.
- Aspect ratio is the section height divided by section width, and is measured as a percentage.
- Static loaded radius (SLR) is the dimension measured from the axle centerline to the ground when the tire is under load. SLR is usually specified at the tire's maximum load and inflation for that particular tire.
- Overall diameter is twice the section height of a new tire, including 24-hour inflation growth, plus the nominal rim diameter.

Rolling circumference (RC) is the distance traveled in one revolution of the tire under maximum load and inflation for that particular tire on a level, paved surface (for a measurement method, refer to ISO, 1997). The rolling circumference index (RCI) system is based on a

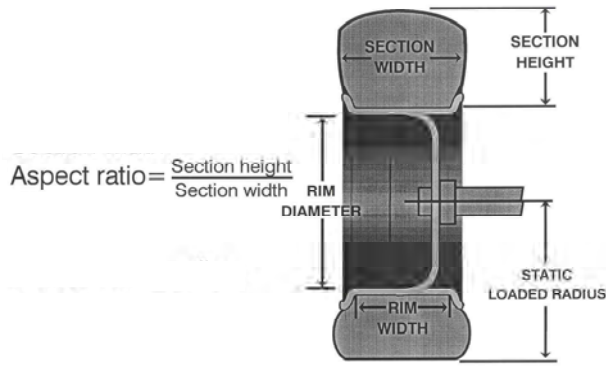

Figure 1. Tire terminology.

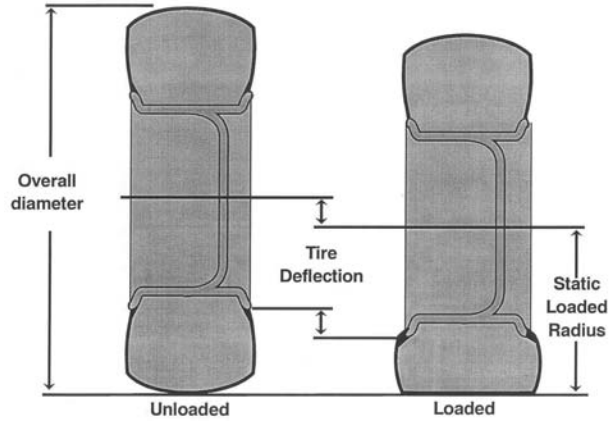

Figure 2. Tractor tire, unloaded and loaded.

geometric progression in which each indexed rolling circumference is a constant proportion to the rolling circumferences above and below it (for the calculation method, refer to Tire and Rim Association, 1997). Table 1 lists RCI and RC values for agricultural tires.

Cyclical loading means the tire load cycles between the maximum allowable load and the transport load. Unloading must occur before road transport. Maximum load may not be carried for more than one mile before unloading operations begins (refer to the appropriate cyclic load and inflation tables; Tire and Rim Association, 2003a).

## Example Tire Construction Designations

Radial tire, standard size is indicated as 18.4R46 (3\*) (fig. 3):

- 18.4 = tire section width in inches.
- R = radial construction
- 46 = rim diameter in inches
- (3\*) = load designation per load and inflation tables 5-(14-16) (Tire and Rim Association, 2003a).

Radial tire, metric size is indicated as 480/80R46 155A8 (fig. 3):

- 480 = tire section width in mm
- 80 = aspect ratio as a percentage
- R = radial construction
- 46 = rim diameter in inches
- 155 = load index value (fig. 4 and table 2)
- A8 = refers to a speed of 25 mph (40 km/h).

Bias-ply tire, size is indicated as 18.4-38 (10):

- 18.4 = tire section width in inches
- = denotes bias ply
- 38 = rim diameter in inches
- (10) = ply rating, not the actual number of plies.

Flotation bias-ply tire, size is indicated as 76x50.00B32 standard, or 1250/45B32 metric (fig. 5):

- 76 = tire design diameter in inches
- 50.00 = tire section width in inches
- B = denotes the tire has tread plies in the crown of the tire
- 32 = rim diameter in inches.



Figure 3. Standard and metric size designation.

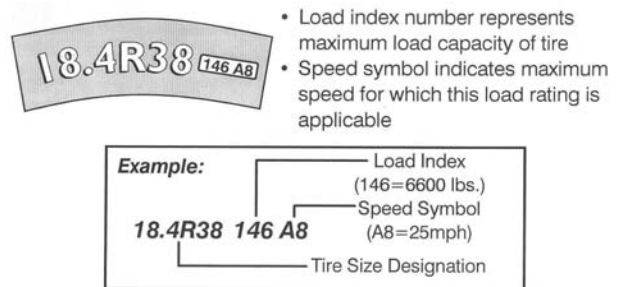

Figure 4. Load index and speed symbol.

**Table 1. Rolling circumference tire families.<sup>[a]</sup>**

RCI <sup>[b]</sup> Group	RC <sup>[c]</sup> (in.)	OD <sup>[d]</sup> (in., approx.)	Minimum Recommended Row Width <sup>[e]</sup>						40+ Non-Row Crop	Flotation																																		
			18	20	22	26	30	32																																				
48	243	81	290 (11.2)	320 (12.4)	380 (14.9)	420 (16.9)	480 (18.4)	520 (20.8)	620 (24.5)	710 (28.0)	800-900 (30.5-35.5)	1000+ (40+)																																
													47	230	77	320/90R54 (12.4R54)	380/90R50	420/80R46	480/80R50	520/85R46	650/85R38	710/70R42	800/70R38 900/65R32	76×50-32 78×45-32 VA73×44-32																				
																									46	219	73	320/90R50	380/90R46 (14.9R46)	420/80R46	480/80R42 (18.4R42)	520/85R38 (20.8R38)	620/70R42	900/50R42 900/60R32	68×50.00-32									
																																				45	207	69	320/90R46	480/80R38 (18.4R38)	520/85R32 (24.5R32) (23.1R34)	600/65R38	800/65R32 (30.5LR32) 67×34.00-25	68×50.00-32
43	187	63	320/90R42 (12.4-42)	380/80R38	420/85R34	480/70R34	540/65R34	600/70R30 (23.1-26)	620/75R30 (23.1-30)	66×43-25 66×44-25																																		
											42	177	59	320/85R38 (12.4-38)	380/85R34 (14.9R34)	420/90R30 (16.9R30)	480/70R30 (18.4-30)	540/65R30	600/65R28	58×31.00-26																								
																					41	168	56	290/95R34 (14.9R30)	380/85R30 (16.9R28)	420/85R28 (18.4R26)	480/70R28 (18.4R26)	540/65R28	800/50-25 54×31.00-25															
40	160	53	380/85R28 (14.9R28)	420/85R26 (16.9R26)	480/65R28	540/65R24	48×25.00-20	48×31.00-20																																				
									39	152	50.5	340/85R28 (13.6R28)	480/65R24	480/65R24	48×25.00-20	48×31.00-20																												

<sup>[a]</sup> Tire sizes are listed in metric (and standard) dimensions:

All sizes in the same row are approximately the same outside diameter.

All sizes in the same column are approximately the same width.

For specific applications, consult OEM data books for actual dimensions.

<sup>[b]</sup> RCI = rolling circumference index; indicates family of tires with similar rolling circumferences (Tire and Rim Association, 1997).

<sup>[c]</sup> RC = rolling circumference (ISO, 1997).

<sup>[d]</sup> OD = overall diameter, the approximate height of the tire in inches.

<sup>[e]</sup> The minimum row width in which the operator can comfortably guide the tire between the crop rows.

**Table 2. International load index numbers, kilogram loads, and equivalent pound loads (Goodyear, 2003b, pp. 13).**

Load Index			Load Index			Load Index		
Index	kg	lbs	Index	kg	lbs	Index	kg	lbs
80	450	990	120	1400	3080	160	4500	9900
81	462	1020	121	1450	3200	161	4625	10200
82	475	1050	122	1500	3300	162	4750	10500
83	487	1070	123	1550	3420	163	4875	10700
84	500	1100	124	1600	3520	164	5000	11000
85	515	1140	125	1650	3640	165	5150	11400
86	530	1170	126	1700	3740	166	5300	11700
87	545	1200	127	1750	3860	167	5450	12000
88	560	1230	128	1800	3960	168	5600	12300
89	580	1280	129	1850	4080	169	5800	12800
90	600	1320	130	1900	4180	170	6000	13200
91	615	1360	131	1950	4300	171	6150	13600
92	630	1390	132	2000	4400	172	6300	13900
93	650	1430	133	2060	4540	173	6500	14300
94	670	1480	134	2120	4680	174	6700	14800
95	690	1520	135	2180	4800	175	6900	15200
96	710	1570	136	2240	4940	176	7100	15700
97	730	1610	137	2300	5080	177	7300	16100
98	750	1650	138	2360	5200	178	7500	16500
99	775	1710	139	2430	5360	179	7750	17100
100	800	1760	140	2500	5520	180	8000	17600
101	825	1820	141	2575	5680	181	8250	18200
102	850	1870	142	2650	5840	182	8500	18700
103	875	1930	143	2725	6000	183	8750	19300
104	900	1980	144	2800	6150	184	9000	19800
105	925	2040	145	2900	6400	185	9250	20400
106	950	2090	146	3000	6600	186	9500	20900
107	975	2150	147	3075	6800	187	9750	21500
108	1000	2200	148	3150	6950	188	10000	22000
109	1030	2270	149	3250	7150	189	10300	22700
110	1060	2340	150	3350	7400	190	10600	23400
111	1090	2400	151	3450	7600	191	10900	24000
112	1120	2470	152	3550	7850	192	11200	24700
113	1150	2540	153	3650	8050	193	11500	25400
114	1180	2600	154	3750	8250	194	11800	26000
115	1215	2680	155	3875	8550	195	12150	26800
116	1250	2760	156	4000	8800	196	12500	27600
117	1285	2830	157	4125	9100	197	12850	28300
118	1320	2910	158	4250	9350	198	13200	29100
119	1360	3000	159	4375	9650	199	13600	30000



**Figure 5. Flotation size designation.**

## Load Ratings

In the past, bias-ply or cross-ply tires were rated by the actual number of plies used in the tire to carry the vertical load. A 6-ply tire had six actual plies and carried 2000 lbs. During and after World War II, man-made materials such as nylon, polyester, rayon, and steel become available for the tire body and are several times stronger than the original cotton body plies. Today, an 8-ply rated tire may have only six actual plies, but it carries an 8-ply load rating.

Radial tires originally carried the same ply rating with equivalent loads and inflation pressures as the equivalent-size bias tire. In 1987, the Tire and Rim Association increased the radial load by 7% over the equivalent-size bias tire. This change allowed radial tires to better utilize their radial construction for better traction and load capabilities than bias tires.

At the same time, the Tire and Rim Association created a star rating system for radial tires to denote a maximum pressure for a given load rating. This eliminated the varied inflation pressures called for in the bias load tables (see bias load table example; Tire and Rim Association, 2003b). No matter what size of radial tire, all one-star tires' maximum inflation is 18 psi (fig. 6 and table 3). Each additional star rating requires an additional 6 psi increase in inflation pressure (Tire and Rim Association, 2003b, pp. 5-12).

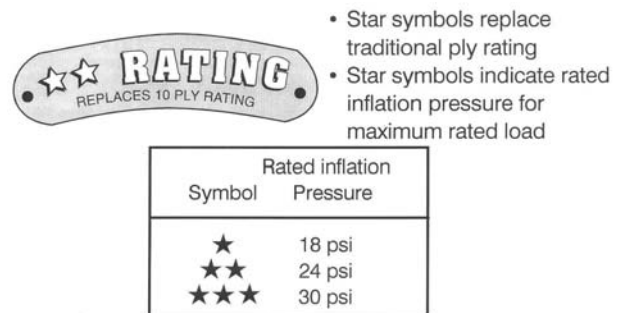

**Figure 6. Radial star symbol per maximum inflation pressure.**

**Table 3. Radial star, service index, and ply rating comparison.**

Tire Size	Symbol	Service Index	Ply Rating
20.8R42	*	149A8	10
	**	155A8	
	***	159A8	
23.1R34	*	151A8	8
	**	157A8	
	***	161A8	
24.5R32	*	154A8	10
	**	159A8	
	***	164A8	
30.5LR32	*	159A8	10, 12
	**	166A8	
	***	170A8	

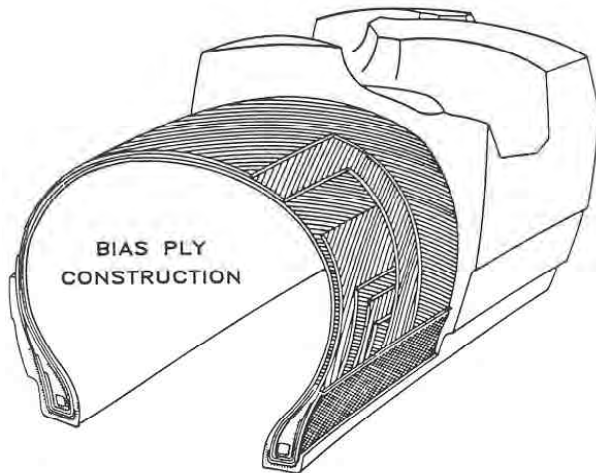

Figure 7. Bias-ply tire construction.

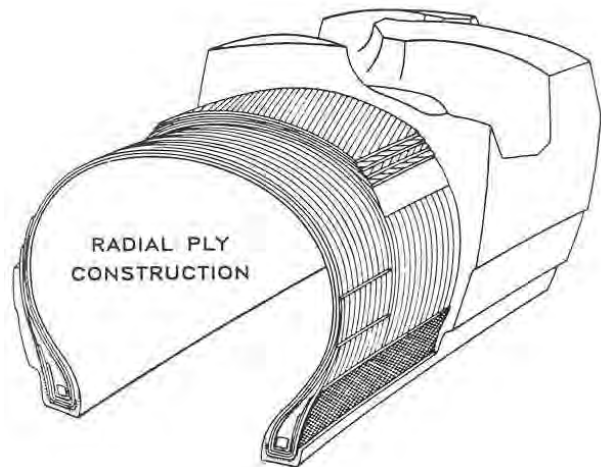

Figure 8. Radial tire construction.

## Bias Tire Construction

The carcass of a bias-ply tire consists of layers (or plies) of fabric with cords that run diagonally from bead to bead at an angle called a bias angle (fig. 7). The cords of adjacent plies run in opposite directions, giving stability to the tire. The sidewalls of a bias tire are relatively stiff due to this criss-crossing of the body plies.

The bias tire's relatively stiff sidewall offers advantages over the radial tire in certain applications, such as forestry, where the radial tire sidewall can be prone to cuts and punctures while working in a severe environment.

Because of the criss-crossing of the body plies, the bias tire has more internal friction than the radial tire. This is one of the major reasons that bias tires have been replaced in many applications, the radial runs cooler and more efficiently. Depending on conditions, radial tires show an advantage of 6% to 14% in traction, fuel efficiency, and reduced wheel slippage over bias tires.

## Radial Tire Construction

The body cords of a radial tire run parallel to each other from bead to bead at right angles to the tread centerline (fig. 8). Radial tires also have stabilizer plies (or belts) beneath the tread, with cords that run in a nearly circumferential direction (at a small angle to the tread center-line). Most of the flexing in the radial tire occurs in the sidewall area, while the tread area remains relatively stiff due to the belts.

## Tread Designs for Powered Axles

There are five principle drive tire tread designs: R1, R1W, R2, R3, and R4 (fig. 9).

R1 tread is used for general farming and typically provides the best traction in most soil conditions. The tread is an aggressive pattern for developing traction in hard to soft soil conditions. The tread void area is approximately 70% of the total footprint for good cleaning in wet soils and good penetration in firmer soils.



Figure 9. Basic drive tire tread patterns.

R1W tread originated in Europe and has a 20% deeper skid depth than R1. European tractors often spend a higher percentage time on paved surfaces, and the deeper tread increases tire life. This tread depth is popular in Europe and is becoming more prominent in North American markets.

R2 tread is used in wet farming applications where the machine must run through mud and standing water. Typical applications are rice, sugar cane, and high-value vegetable crops. The tread is twice as deep as the standard R1 tread. While R2 looks extremely aggressive, the typical 45° bar angle is maximized for cleaning in wet soils and is not as efficient for developing traction as R1 in general farming conditions.

R3 tread is a non-aggressive pattern where minimal ground disturbance is required, such as for airports, golf courses, cemeteries, roadside maintenance, dryland combining, and on large heavy trailers such as manure and grain carts. The tread typically has a relatively closed tread pattern to evenly distribute the load, with void area in the 30% range.

R4 treads are for construction and light industrial equipment such as backhoes and small end loaders. The tread depth is approximately 70% of the R1 tread and is designed for good wear on roads and reasonable traction on soils at a construction site. The tread-to-void ratio is typically 50/50.

## Choosing the Right Tire for MFD Tractors

For many years, tractors were powered by a single drive axle; this is called a two-wheel drive tractor. Front wheel assist tractors became available in the 1960s and 1970s. They offered a hydraulically powered front axle with one or two field speeds for extra traction. In the 1960s through the 1980s, tractor manufacturers began to offer tractors with mechanically powered front axles, called mechanical front drive (or MFD) tractors. These tractors have a mechanical drive shaft that powers the front axle and allows the tractor to utilize the front axle in every gear of the tractor's transmission.

Because the front and rear tires are of different diameters, matching the front and rear tires is important for proper gearing between the two axles. A desired overspeed on the front tire, relative to the rear, is in the range of 0% to 6%, depending on the tractor manufacturer. Rolling circumference is the best dimension to work with in calculating the lead/lag of the two axles on an MFD tractor. In the past, tractor engineers, implement manufacturers, and tire dealers had to work through these calculations to determine the proper front and rear tire sizes. Today, the tractor and tire industries have attempted to standardize new tires and tractors within the RCI chart (table 1).

The RCI chart (table 1) lists sizes of tires with equivalent RCI values from the narrowest to the widest tires that are commercially available. The RCI groups in table 1 are listed by tire diameter, from largest to smallest, for high-horsepower row crop tractors. RCI groups 48 to 45 are considered rear-axle sizes, and RCI groups 44 to 39 are considered front-axle sizes. Obviously, smaller MFD tractors can utilize the chart, but the RCI indices need to be extended to incorporate the smaller front drive tire families.

North American tractor manufacturers largely use a 5-step RCI difference between the front and rear axle. Any group 47 rear tire will match up with any group 42 front tire. For example:

Rear = 18.4R46 RCI 47

Front = 14.9R34 or 16.9R30; both are RCI 42 tires.

European tractor manufacturers often use a 4-step difference. A 710/70R38 group 47 rear tire will match up with a 600/70R30 group 43 front tire. Basically, any row of rear sizes will match up with the corresponding row of front sizes because they are within the accepted range of RC values.

## Creating a New Low-Pressure Traction Tire

As equipment continues to increase in size, horsepower, and weight, tougher demands are made on tires. The tire industry was challenged to create a tire for a high-horsepower four-wheel drive tractor that would fulfill the following criteria:

- Easily control power hop with higher load capacity without an increase in inflation pressure and keep soil compaction to a minimum (Wiley, 1992; Abu-Hamdeh, 1995a).
- Maximum overall diameter of approximately 206 cm (81 in.), RCI group 48, for current tractor chassis limits.
- Maximum width of 800 mm, so that the overall width on a 4WD tractor with dual tires is under 490 cm (16 ft).
- Minimum rim diameter of 38 inches to minimize the chance of rim slip and yet provide the largest air chamber within the tire to maximize load capacity.

Existing large rear sizes include the 710/70R42 tire in group 48 and a 900/50R42 tire in group 47. Neither tire adequately controls power hop on the larger 4WD tractors. Subtracting the 38 inch rim diameter from the 206 cm (81 in.) OD for RCI 48 leaves 109 cm (43 in.) of tire section height. Dividing the 109 cm (43 in.) by 2 leaves a single section height of 54.6 cm (21.5 in.). The aspect ratio is the section height divided by the section width. In this case, we have 54.6 cm (21.5 in.) divided by a maximum section width of 800 mm, for an aspect ratio of 68.2%. Rounding to 70% then describes the new size as an 800/70R38 173A8 at 160 kPa (23 psi) (fig. 10).



Figure 10. 710/70R42 tires versus 800/70R38 tires.

The new size provides up to 6500 kg (14,300 lbs) of vertical load capacity at 160 kPa (23 psi) at 40 km/h (25 mph) for tractors. For cyclical work on combines, the tire will carry 11,100 kg (24,300 lbs) at 10 km/h (6 mph) at 200 kPa (29 psi).

## Creating a New High-Load Narrow Tire

The farming industry continues to move from mechanical weed control to liquid herbicides applied with high-capacity row crop sprayers. Again, faster speeds and larger payloads are demanded by the original equipment manufacturers. The machine requirements are as follows:

- Operate a fully loaded sprayer at transport speed of 50 km/h (30 mph) within the Tire and Rim Association's load formula.
- Maximum overall diameter of approximately 206 cm (81 in.), RCI group 48, for maximum ground clearance and fit within the existing RCI group 48 family of tractor sizes.
- Maximum width of 380 mm (14.9 in.) so that the tires will negotiate 30 inch crop rows.
- Minimum rim diameter of 46 inches to fit around planned wheel accessories.
- Load per tire is just under 5440 kg (12,000 lbs).

The smaller size most often used on existing machines is the 380/90R46 R1W. This tire will carry 3875 kg (8550 lbs) at 320 kPa (46 psi) and has an overall diameter of 182 cm (71.8 in.) in RCI group 46. However, the new sprayers require higher loads, and the tire must be able to operate on a continual basis at full load and not reduce sprayer performance due to heat concerns while running at 50 km/h (30 mph).

A portion of the Tire and Rim Association's load formula utilizes contained air volume and internal inflation pressure to calculate the maximum load for the tire.

Table 4. Tire size, load index, load, and inflation pressure.

Tire Size	Load Index	Load		Inflation	
		kg	lbs	kPa	psi
380/90R54	152	3550	7850	240	35
380/90R54	168	5600	12,300	480	70
380/105R50	168	5600	12,300	440	64

In this case, the overall diameter and section width are fixed. The only remaining variables are the section height and rim diameter. Obviously, the largest air volume will provide the largest load capacity at the lowest internal tire pressure. A lower tire pressure is desirable both for minimizing soil compaction and for minimizing stresses within the tire and wheel.

The existing tractor tire size that fits the diameter and width is the 380/90R54 152A8/B. However, the rated load is much lower than the required 5440 kg (12,000 lbs). The load and inflation for the tractor tire are 3550 kg at 200 kPa (35 psi). To reach the required load, the 380/90R54 requires 480 kPa (70 psi) (table 4).

A lower inflation pressure is desirable. Increasing the tire internal volume will require a larger aspect ratio and a correspondingly smaller rim. The approximate overall diameter for the 380/90R54 tire, or any metric marked tire, is calculated as:

$$OD = \text{section width} \times \text{aspect ratio} + \text{rim diameter}$$

In this case:

$$\begin{aligned} OD &= (380 \text{ mm} \times 90\% \times 2 \text{ sections}) + \\ &\quad (54 \text{ in. rim diameter} \times 25.4 \text{ mm/in.}) \\ &= 2,056 \text{ mm (80.9 in.)} \end{aligned}$$

This value is approximate because of tire growth tolerances with inflation and usage. Agricultural rims, typically, run in 4-inch graduations. The next smaller rim diameter is 50 inches in diameter and is commercially available. The aspect ratio required to meet the previously listed criteria is calculated as:

$$\text{Aspect ratio} = \frac{(\text{overall diameter} - \text{rim diameter})}{(\text{section width} \times 2 \text{ sections})} \times 100\%$$

In this case:

$$\text{Aspect ratio} = \frac{(2056 \text{ mm} - 50 \text{ in.} \times 25.4)}{(380 \text{ mm} \times 2)} \times 100\% = 103.4$$

or 105%, when rounded to the closest value divisible by 5, which suggests the 380/105R50 tire (fig. 11).

## What is a Cyclical Loaded Tire?

Harvesting, spraying, and fertilizer work involve cyclical loaded tires. The load ratings for both bias-ply and radial tires for these operations reflect a different duty cycle when compared to agricultural tractors. Cyclical service ratings are intended for use on vehicles with minimal requirements for torque transmission and with



Figure 11. 380/105R50 tire.

appreciable total weight fluctuations (e.g., combine grain tanks that are repeatedly filled and emptied, when unloading occurs before off-field transport).

Bias-ply tires (Tire and Rim Association, 2003b):

- Require a 30% inflation increase over the standard tractor inflation pressure.
- At 10 km/h (6 mph), tractor loads can be increased an additional 87%.
- At 15 km/h (10 mph), tractor loads can be increased an additional 70%.

Radial tires (Tire and Rim Association, 2003c):

- Require a 40 kPa (6 psi) inflation increase over the standard tractor inflation pressure.
- At 10 km/h (6 mph), tractor loads can be increased an additional 70%.
- At 15 km/h, (10 mph) tractor loads can be increased an additional 55%.

Due to the higher inflation pressures specified for these tires, tire and wheel manufacturers must be consulted.

If a farmer purchases a larger machine and keeps the same size tire, then the inflation pressure must be increased to carry the heavier mass. This higher inflation pressure causes increased soil compaction; therefore, lower inflations pressures are more desirable on soft soils (Abu-Hamdeh, 1995b). Choosing larger single tire and/or larger radial dual configurations will minimize soil compaction and maximize flotation along with increased yields and profits for the customer (table 5).

If dual tires are used, loads must be multiplied by 0.88. This protects tires when running over uneven surfaces and crowned roads. In these conditions, one of the two tires could carry a disproportionate part of the machine weight (Tire and Rim Association, 2003b).

Table 5. Combine tire options.

Axle Configuration	Tire Size	Load Index	Axle Load (kg)	Tire Pressure (kPa)
Single	800/65R32	172	21,400	280
Dual	20.8R42	155	23,200	210
Single	76×50.00-32	176	24,500	140

What can the industry expect in the future? Larger machines with tires requiring higher load capacities and higher transport speeds, all at a lower cost to the customer. Central tire inflation systems are currently being used and sold in Europe that increase inflation for high transport speeds and reduce inflation for slower field speeds. This allows for extended tire durability on the road and less soil compaction in the soft fields.

## Summary

This lecture provided a short history of agricultural tractors and wheel equipment, beginning with steam tractors and early internal combustion engines with steel wheels, through the first pneumatic tire used at the Nebraska tractor test, to today's high-performance machinery capable of speeds in excess of 50 km/h (30 mph).

A list of basic tire terms used to describe the tire profile was covered, along with performance criteria used to match mechanical front drive axles to the rear axle for proper gearing. In addition, the RCI table was introduced to provide a visual example of how tires can be grouped by rolling circumference and overall diameter.

A description of tire size designations was listed for bias, radial, and flotation sizing. The load rating designations for ply, star, and load index were also explained. The five most common tread designs for powered axles were defined, with examples of the different patterns.

Two examples of the creation of new tire sizes were given: one for large, high-horsepower, four-wheel drive tractors, and one for high-capacity row crop sprayers. Cyclical loads and their restrictions were also discussed.

## References

- Abu-Hamdeh, N. H., T. G. Carpenter, R. K. Wood, and R. G. Holmes. 1995a. Soil compaction of four-wheel drive and tracked tractors under various draft loads. SAE Technical Paper 952098. Warrendale, Pa.: SAE.
- Abu-Hamdeh, N. H., T. G. Carpenter, R. K. Wood, and R. G. Holmes. 1995b. Combine tractive devices: Effects of soil compaction. SAE Technical Paper 952159. Warrendale, Pa.: SAE.
- Goodyear. 2003a. Landmarks in tire design. Available at: [www.goodyear.com/about/history.html](http://www.goodyear.com/about/history.html).

- Goodyear. 2003b. Farm tire handbook. Available at: [www.goodyearag.com/img/tires/farmFarmHndbk\\_1.pdf](http://www.goodyearag.com/img/tires/farmFarmHndbk_1.pdf).
- ISO. 1997. ISO 11795: Agricultural tractor drive wheel tires—Method of measuring tire rolling circumference. Geneva, Switzerland: ISO.
- Lief, A. 1951. *The Firestone Story*. New York, N.Y.: Whittlesey House, a McGraw-Hill Company.
- Tire and Rim Association. 1997. *Engineering Design Information*, section 5-20. Copley, Ohio: Tire and Rim Association.
- Tire and Rim Association. 2003a. Cyclic load and inflation tables. In *Engineering Design Information*, section 5-26 to 5-29. Copley, Ohio: Tire and Rim Association.
- Tire and Rim Association. 2003b. Bias cyclic loads. In *Engineering Design Information*, section 5-26 to 5-27. Copley, Ohio: Tire and Rim Association.
- Tire and Rim Association. 2003c. Radial cyclic loads. In *Engineering Design Information*, section 5-28. Copley, Ohio: Tire and Rim Association.
- Wendel, C. H. 1985. Test No. 223. In *Nebraska Tractor Tests Since 1920*. St. Paul, Minn.: Motorbooks International.
- Wiley, J.C., B. E. Romig, L. V. Anderson, and F. M. Zoz. 1992. Optimizing dynamic stability and performance of tractors with radial tires. ASAE Paper No. 921586. St. Joseph, Mich.: ASAE.