

B. DRAFT CONTROL LEVER (IF EQUIPPED)

1. Lower the elevating arm, loosen the lock nut (1) and push backward.
2. Disengage the lock bolt (2).
3. Adjust the length of the feedback rod.

Length of feedback rod (L)	Reference dimension	135 mm 5.3149 in.
----------------------------	---------------------	----------------------

4. With minimum rpm, lower the position control lever (6) to the stopper (8), and then slowly raise the Draft control lever (5) toward the stopper (7) so that the elevating arm might be raised.
5. Decrease and adjust the length (L) of feedback rod gradually one rotation a time, until the rod smooth lowers.
6. After a completion of the adjustment, tighten the nut (1) and lock bolt (2).

(Ref.)

When raised to max. using the Draft control lever, height (H) will be higher between 15 and 20 mm (0.59 ~ 0.79 in.) than the max, using the position control lever.

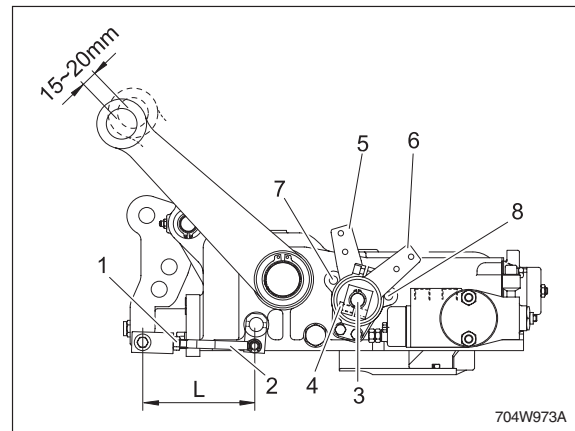

- (1) Nut
- (2) Bolt
- (3) Position Control Shaft
- (4) Hex. Bolt
- (5) Draft Control Lever
- (6) Position Control Lever
- (7) Stopper
- (8) Stopper

4.4.6 SENSIBILITY ADJUSTMENT

Position the rockshaft lifting arms, with a weight applied, so that they reach about half their angular movement range.

In this way the Control Valve is positioned in its neutral phase.

Loosen nut "A" and turn the embedded hexagonal screw "B" in a counterclockwise direction until the lifting arms start swaying continuously.

With a slow movement stop the movement of the arms by rotating screw "B" in a clockwise direction.

When the arms remain blocked in their position, which can be controlled with the relevant instrument positioned on the end of the lifting arm, rotate (clockwise) the screw "B" for 1/2~3/4 of a turn max. Lock the position with the self-locking nut "A".

In this way the Control Valve is sensitivity adjusted.

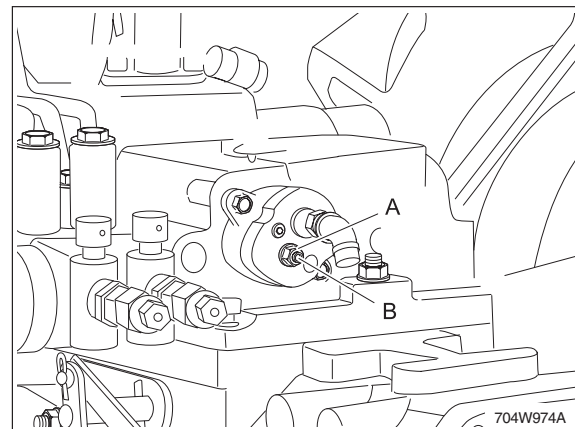

- (A) Nut
- (B) Screw

- GENERAL
- ENGINE
- CLUTCH
- TRANSMISSION
- HST
- REARAXLE
- BARKE
- FRONTAXLE
- STEERING
- HYDRAULIC**
- ELECTRIC
- INDEX