

FREDRICKS FAMILY 4

**Mounting Instructions
With Parts Listing and Drawing For**

2-POST FOLDING ROLLBAR

**Part No.
A-11366**

Manufactured by:



BOX 718 • LITCHFIELD, MINNESOTA 55355

Ph: (320) 693-3221 Fax: (320) 693-7252

1-800-222-5463

www.800cabline.com

INSTALLATION INSTRUCTIONS FOR ROLLOVER PROTECTION SYSTEM (ROPS)

This manual contains assembly, operating, maintenance and safety instructions for your ROPS. Before installing the ROPS or operating a machine equipped with a ROPS, carefully read these instructions completely. The ROPS will reduce the risk of serious or fatal injury in the unlikely event of a tip over although the system cannot protect the operator from all possible injuries. By following the operating, maintenance, and safety instructions, you will prolong the life of the machine and the ROPS, maintain its maximum efficiency and promote safe operation.

If additional information is needed, contact your authorized equipment dealer or distributor. **Keep this manual with the operator's manual for the machine for future reference.**

IMPORTANT:

1. Do not cut, drill, modify or repair ROPS in any manner.
2. Always replace a damaged ROPS.
3. Always use the seatbelt and ROPS together.
4. Frequently inspect rollbar and seat belts for damage or loose hardware.
5. Use extreme care when working close to fences, ditches, trees and on hills.
6. Check overhead clearances carefully before driving under any objects.
7. Do not leave operator's position while unit is running.
8. Do not carry riders.

WARNING!

This ROPS is certified for use on machines with a maximum gross vehicle weight (GVW) of 4000 LB. The GVW INCLUDES the weight of the base machine, operator, fuel, ROPS, and other attachments and payloads. When attachments are added, causing the GVW of the machine to be more than 4000 LB., the ROPS may not provide adequate protection resulting in serious injury or death. Use caution when installing attachments and **DO NOT EXCEED** the GVW rating of the ROPS.

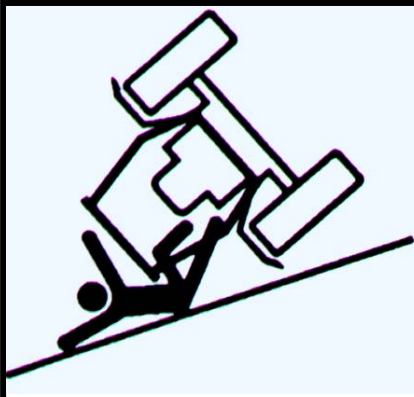

WARNING!

SERIOUS INJURY OR DEATH MAY RESULT FROM MACHINE ROLLOVER

- DO NOT OPERATE MACHINE ON STEEP SLOPES OR NEAR DROP OFFS
- ALWAYS USE SEAT BELTS
- AVOID SHARP AND/OR QUICK TURNS
- DO NOT EXCEED THE MACHINE WEIGHT RATING OF THE ROPS

WARNING

ROLLOVER MAY CAUSE PERMANENT INJURY OR DEATH.

- ROPS RAISES THE CENTER OF GRAVITY AND REDUCES STABILITY ON SLOPES.
- SUDDEN STARTS OR TURNS ON RAMPS OR SLOPES CAN CAUSE OVERTURN.
- USE GREATER CARE ON RAMPS AND AS THE SLOPE INCREASES.

MOUNTING INSTRUCTIONS 2-POST FOLDING ROLLBAR

- 1) Park the tractor on a level surface and set the brakes.
- 2) Remove the inside rear fender mounting nuts and washers.
- 3) Remove the lift links from the 3 point lift arms.
- 4) Remove the hole plugs from the (4) 14MM holes in the rear of the axle housing.
- 5) The lower rollbar mount can now be installed onto the tractor. Fasten with (4) 14mm x 40 grd 8.8 bolts, (4) .50" flat washers and (4) .56" lock washers.
- 6) Reinstall the mounting nuts and washers on the inside rear fender mounts.

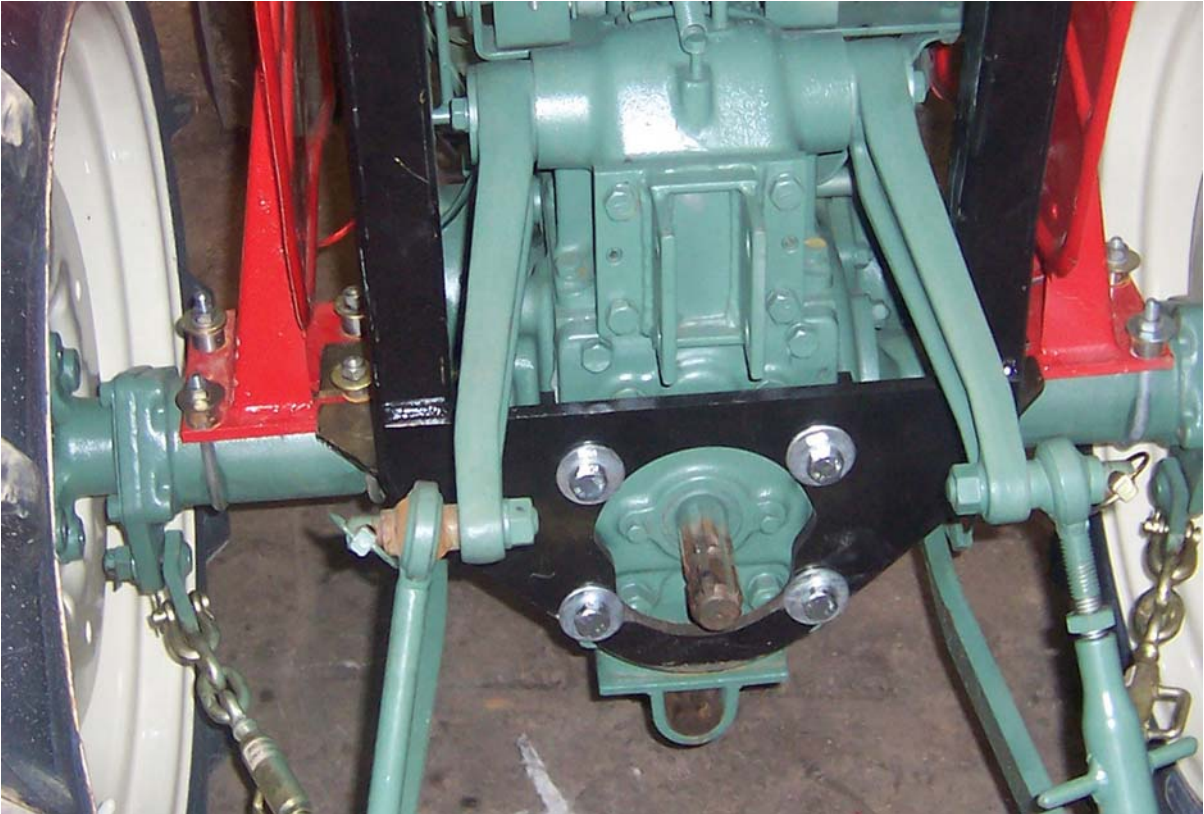

- 7) Install the upper rollbar hoop. Install a rubber bumper into the lower hole on each of the hinge plates. Fasten each side with a .50 x 3.00 bolt, a pin retainer washer and a .50 center lock nut into the upper mount hole. Tighten only until the nut contacts the bracket. Do not over tighten.
- 8) Install a epdm washer onto each of the hitch pins. Position the top hoop into the upright location and install the hitch pins.
- 9) Attach a lanyard to the handle of each hitch pin. Thread it through the retainer washer and attach the spring pin to the eye in the lanyard. Install the spring pins into the hitch pins.

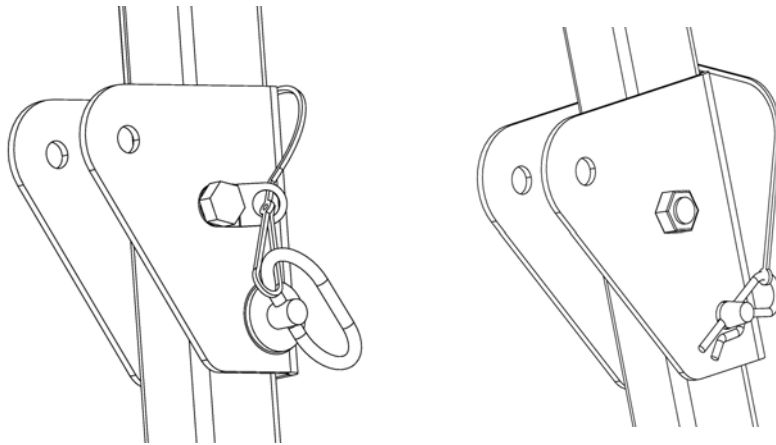

- 10) Install the seat belt to the rollbar with (2) .43 x 1.25 bolts, (4) .43 flat washers and (2) .43 nylock nuts.

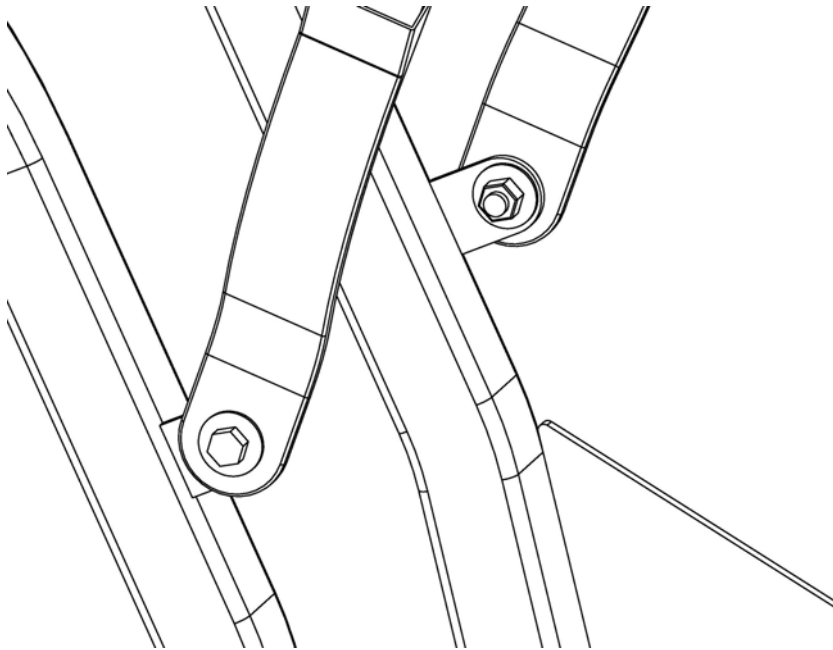

Replacement Parts List
Refer to Drawing #A-11366

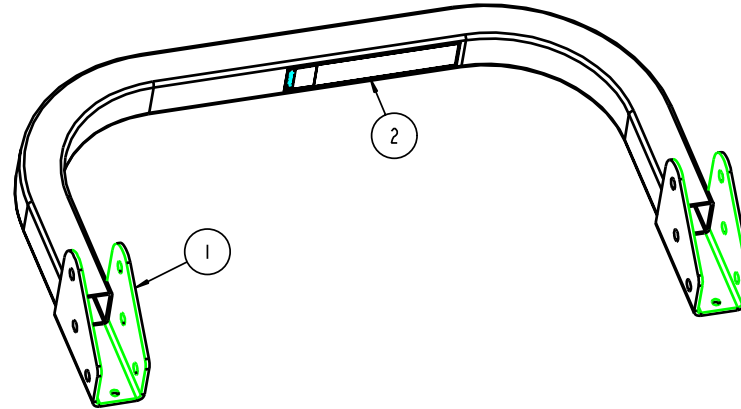
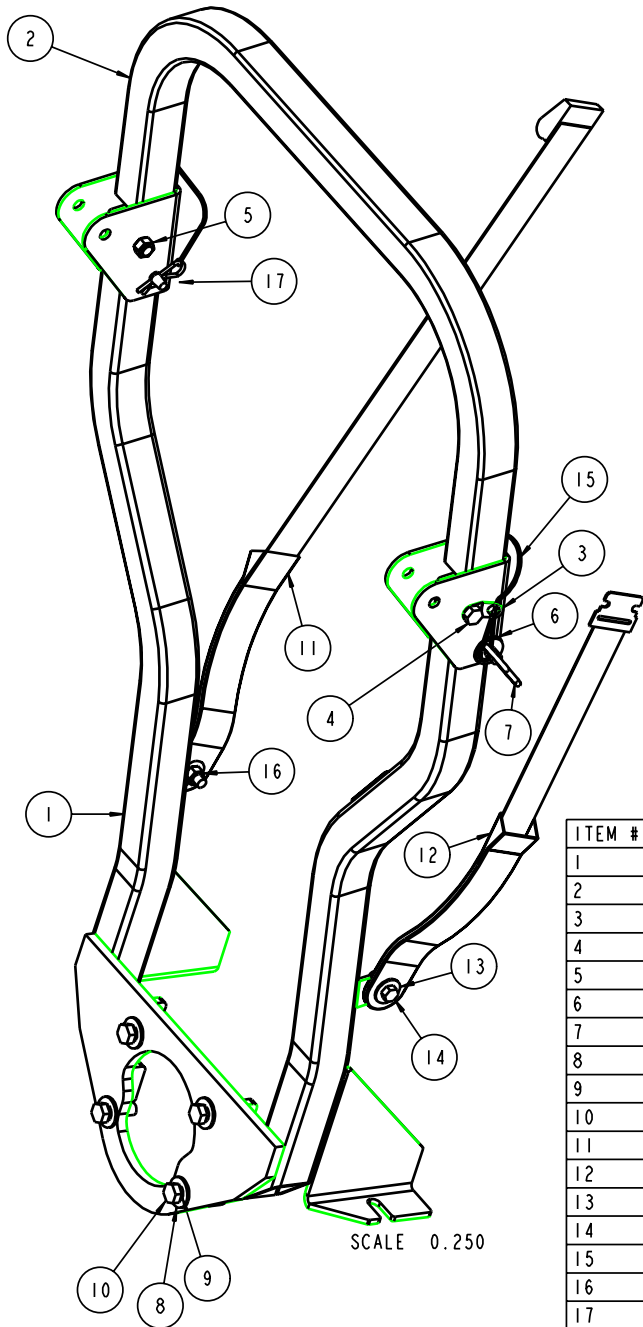

SCALE 0.250

ITEM #	DESCRIPTION	QTY
1	2-16048_WELDMENT_UPPER_HOOP	1
2	3-18401_FOLDING_ROPS_DECAL	1

ITEM #	DESCRIPTION	QTY
1	4-14991	1
2	4-14989_UPPER_HOOP	1
3	3-18413_WASHER_FORMED_RETAIN_50	2
4	3-10131_50_HHCS_X300	2
5	3-10485_50_NUT_HEX_CNTRLOCK	2
6	3-18418_WASHER_EPDM_500	2
7	3-18417_HITCH_PIN_500	2
8	3-10087_50_WASHER	4
9	3-12849_56_LOCK_WASHER	4
10	3-10214_HHCS_M14_X_40	4
11	3-17646_BUCKLE-SIDE	1
12	3-17646_LATCH-SIDE	1
13	3-10166_4375_WASHER	4
14	3-10026_44_HHCS_X125	2
15	3-17811_LANYARD_NYLON_180_LOOP	2
16	3-10472_4375_NYLOCK	2
17	3-18480 BUMPER RUBBER	2

SCALE 0.250

THIS DOCUMENT CONTAINS CONFIDENTIAL INFORMATION AND IS THE PROPERTY OF CUSTOM PRODUCTS OF LITCHFIELD, INC. AND MAY NOT BE COPIED, REPRODUCED OR DISCLOSED IN ANY MANNER WITHOUT EXPRESS WRITTEN CONSENT FROM CUSTOM PRODUCTS OF LITCHFIELD, INC.

TOLERANCES UNLESS NOTED OTHERWISE	CUSTOMER NAME & MOD NO:	FREDRICKS FAM 4	MATL SPEC:
	CUSTOM PRODUCTS 1715 SOUTH SIBLEY AVE LITCHFIELD, MN 55355		
X ± .09 XX ± .06 XXX ± .03 HOLE SIZE 100% DIA ANGLE ± 5°	TITLE:	ROLLBAR ASSEMBLY	REV LEVEL:
	DRWG SIZE:	C	DRWG NO:
			A-11366
	DRWN:	SRB	DATE: 8/3/05