

MF 1040/1045 DUAL CLUTCH

OPERATION

During operation the main friction disc is held against the engine flywheel by the main pressure plate under the influence of the main diaphragm spring. The PTO friction disc is held against the main clutch cover by the PTO pressure plate under the influence of the PTO diaphragm spring.

Initial movement of the clutch pedal rotates the shifter via the shifter rod which slides a release bearing into contact with three release levers. The release levers pivot on the PTO clutch cover and via the connecting links withdraw the main pressure plate rearwards compressing the main diaphragm spring. This action releases the main friction disc. Further downward movement of the clutch pedal will continue to withdraw the main pressure plate still further until the three set screws attached to the main pressure plate contact the PTO pressure plate. The PTO diaphragm spring is then compressed by the action of PTO pressure plate which releases the PTO friction disc. When the clutch pedal is released, the pressure plates return under the action of their respective spring mechanisms.

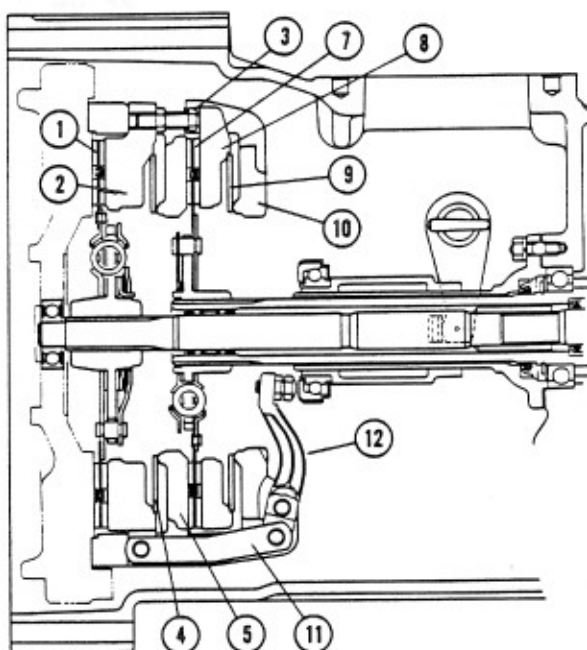

Key

1. Main Friction Disc
2. Main Pressure Plate
3. Set Screws
4. Diaphragm Spring (Main)
5. Clutch Cover (Main)
6. Dowel Pin
7. PTO Friction Disc
8. PTO Pressure Plate
9. Diaphragm Spring (PTO)
10. Clutch Cover (PTO)
11. Connecting Links
12. Lever Kit (Release Lever)

