

SECTION 50 - AUXILIARY UNITS**Chapter 1 - AIR CONDITIONING****CONTENT**

Section	Description	Page
50 000	Specifications	2
	Tightening Torques	2
	Special Tools	2
	Safety Precautions	3
	Description and Operation	4
	Fault Finding and System Testing	15
	Leak Testing, Charging, Discharging and System Flushing	32
	Flushing the System	34
	Evacuating the System	35
	Charging the System	36
	Component Overhaul (excluding compressor)	37
50 200	Compressor Overhaul	44
50 200	Compressor Removal and Installation	44

50 000 SPECIFICATIONS

Refrigerant Specification	New Holland Specification 82000810 (R134a)
Refrigerant Charge	1.1 kg (2.4 lbs)
Compressor Oil Specifications	New Holland Specification 82008750 (PAG Type) (ISO 46 Viscosity) Sanden SP10
Refrigerant Oil Capacity (Compressor and system)	186 cc-228 cc
Cooling capacity @ 22° C - 49° C (75° F - 120°F) ambient.	4.5 kW Typical (Actual capacity dependent on system control operator settings)
Combined High/Low/Fan Pressure Switch (Mounted Adjacent to Compressor)	
Low Pressure Switch	
On	2.06 bar (29.9 lbf/in ²)
Off	1.96 bar (28.4 lbf/in ²)
High pressure Switch	
On	22 bar (319 lbf/in ²)
Off	28 bar (406 lbf/in ²)
Low Pressure Cut Out Switch (Mounted in Evaporator Housing)	
On	2.3 bar (34 lbf/in ²)
Off	0.7 bar (10 lbf/in ²)

COMPRESSOR

Manufacturer and Type	Sanden SD7H15
Compressor Clutch and Pulley Air Gap	0.4-0.8 mm (0.016 and 0.031")
Drive Belt Tension	Automatic Belt Tensioner

TORQUES

Compressor Cylinder Head Bolts		24.5-26.5 Nm (18-19.5 lbf.ft)
Compressor Clutch Front Plate retaining Bolt		11.0-14.0 Nm (8-10 lbf.ft)
Self-sealing Couplings	small	40-54 Nm (29-40 lbf.ft)
	large	54-68 Nm (40-50 lbf.ft)
Compressor Mounting Bolts		20.5-25.5 Nm (15-19 lbf.ft)

SPECIAL TOOLS

Certified Refrigerant Recover, Recycling and Recharge Equipment suitable for the type of refrigerant gas used on tractor are required when servicing air conditioning systems.

This special equipment is available through recognised suppliers of air conditioning equipment. Refer to the Tool supplier for details on the latest equipment available for servicing the air conditioning system.

Vacuum/charge Portable system	New Holland Tool No.294030
Recovery/recharge Portable system	New Holland Tool No.294161
Evaporator and condenser cleaner	New Holland Tool No.293831
Electronic Gas Leak Detector	New Holland Tool No.294036
Manifold Gauge Set (Where required)	New Holland Tool No.292744

COMPRESSOR TOOLS:

Sanden SDH715 Kit	OTC/V.L Churchill Ltd Part No.297422 (NH.50-100)
-------------------	---

SAFETY PRECAUTIONS**WARNING**

Before overhauling an air conditioning system read and observe the following Safety Precautions. If a repair or replacement becomes necessary, ensure that only certified Air Conditioning technicians are employed, using approved equipment to effect repairs. Do **not** attempt to disassemble the air conditioning system, It is possible to be **severely frostbitten or injured** by escaping refrigerant.

IMPORTANT: Do **not** allow refrigerant to escape into the atmosphere.

Refrigerant must be handled with care in order to AVOID HAZARDS.

Undue direct contact with liquid refrigerant can produce freezing of skin and eyes.

Keep the refrigerant container and air conditioning system away from flame or heat sources, the resulting pressure increase can cause the container or system to explode.

If in direct contact with open flames or heated metal surfaces, the refrigerant will decompose and produce products that are toxic and acidic.

Make sure to comply with the following indications and simple precautions to avoid any risk of injury:

- Never discharge refrigerant into the atmosphere. When servicing air conditioning units a certified

refrigerant recovery unit operated by a certified technician must be used.

- When discharging the refrigerant in the system make sure you are operating in well-ventilated premises with good air circulation and far away from open flames.
- When charging and discharging the system always wear goggles and take suitable precautions to protect the face in general and the eyes in particular, from accidental spillage of the refrigerant fluid.
- The oil and refrigerant mixture inside the air conditioning system is pressurized. Consequently, never loosen fittings or tamper with lines unless the system has been properly discharged.
- Before loosening any connection, cover the fitting in question with a cloth and wear gloves and goggles in order to prevent refrigerant from reaching the skin or eyes.
- In the event of an accident, proceed as follows:-
If the refrigerant has reached the eyes, wash them immediately with copious amounts of sterilised water or mains pressure tap water and transfer to hospital for immediate medical help.
If the refrigerant has touched the skin, wash with cold water and transfer to hospital for immediate medical help.

PRINCIPALS OF AIR CONDITIONING

The function of the air conditioning system is to improve the operator's comfort by cooling the air temperature inside the cab and reducing the humidity level.

This temperature control is achieved by absorbing the heat within the cab into a refrigerant and then allowing the heat absorbed by the refrigerant to be transferred to the outside air

In order to achieve this heat transfer the following principals of heat generation and transfer are applied within the air conditioning system.

1. When two bodies of different temperature come together heat is transferred from one to another. On air conditioning systems an evaporator is used to hold the low temperature refrigerant which absorbs the heat from the air within the cab.
2. When a gas is pressurised the temperature of the gas will rise. In air conditioning systems the increase in pressure is achieved using a compressor.
3. When a gas is cooled it will condense into a liquid. In the air conditioning system a condenser is used to cool the gas and the resulting liquid is stored in a receiver dryer.
4. When a liquid is atomized through an orifice, the temperature of the resultant vapour will drop. The low temperature of the atomized liquid will then absorb heat from its surroundings. On air conditioning systems the refrigerant is atomized using an expansion valve.

It can now be seen that the principal components of an air conditioning system are:-

- Refrigerant
- Evaporator
- Compressor
- Condenser
- Receiver Dryer
- Expansion Valve

Figure 5, uses the examples above to illustrate the air conditioning cycle.

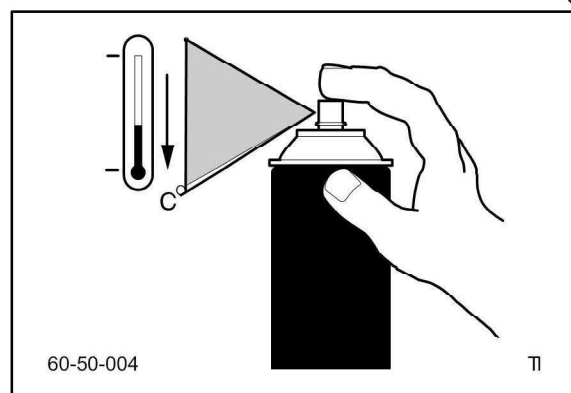
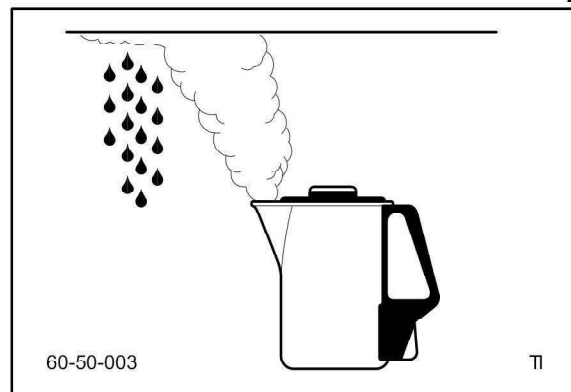
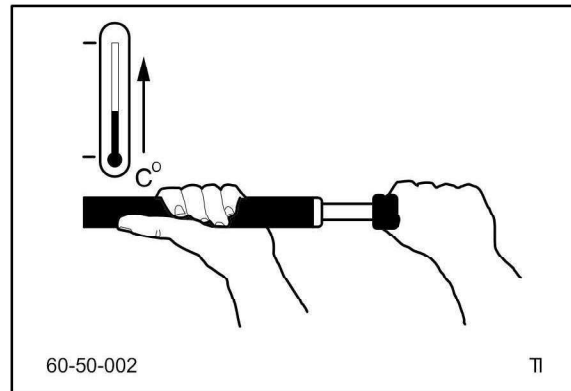
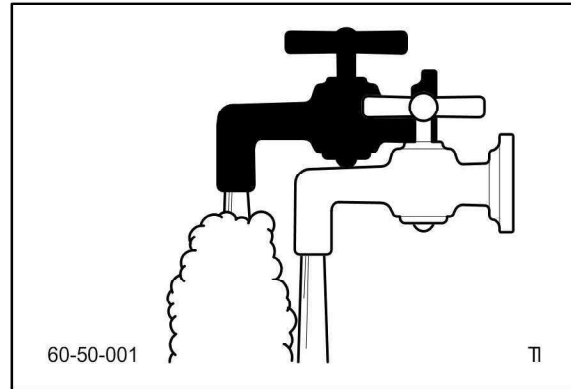

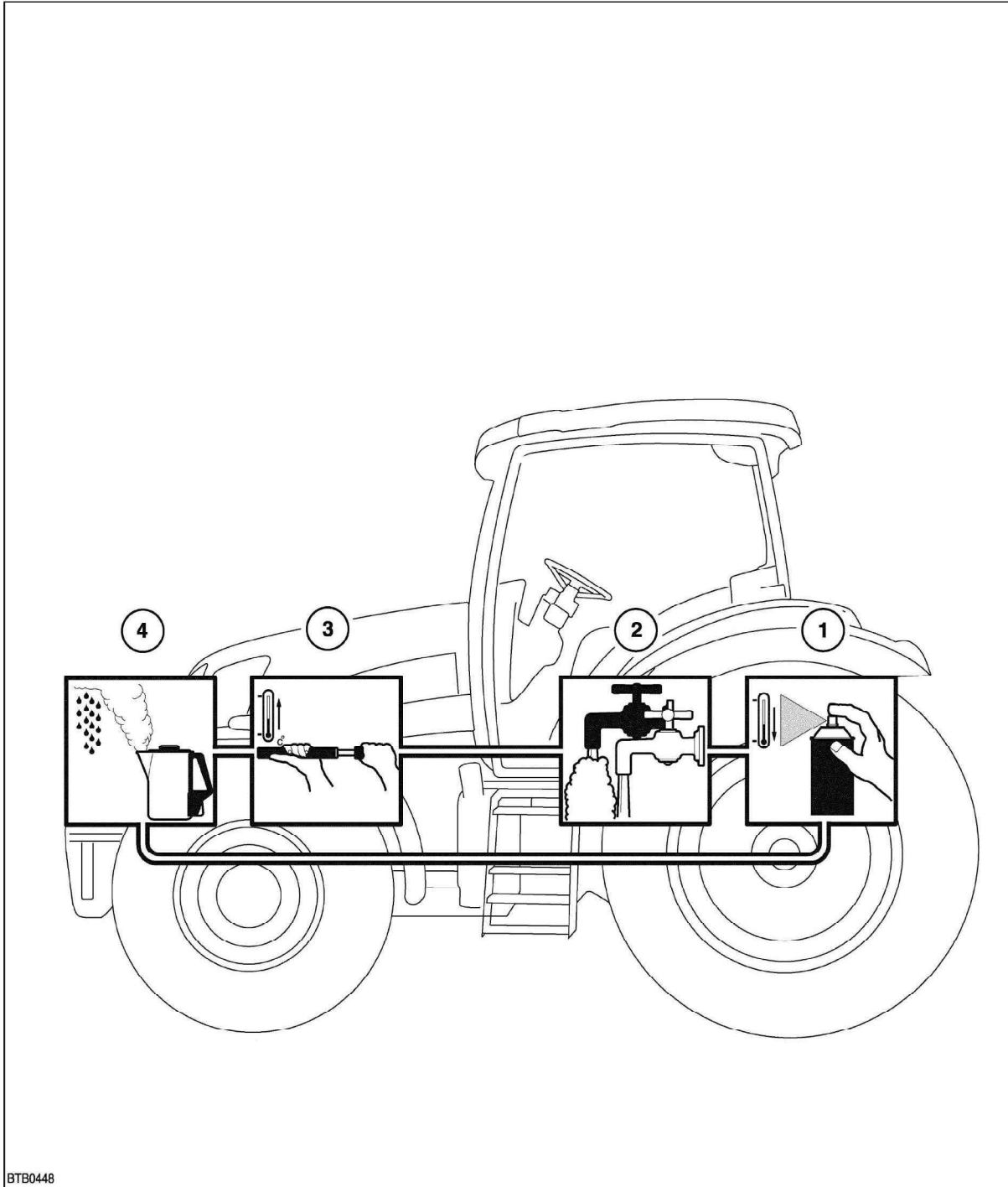

BTB0448

5

Air Conditioning Principal of Operation

1. Expansion Valve - Atomizes Liquid Refrigerant Before Passing to Evaporator
2. Evaporator- Absorbs Heat From Air In Cab
3. Compressor - Compresses and Raises Temperature Of Refrigerant Gas
4. Condenser, Evaporator and Dryer - Converts Refrigerant from Gas to a Liquid

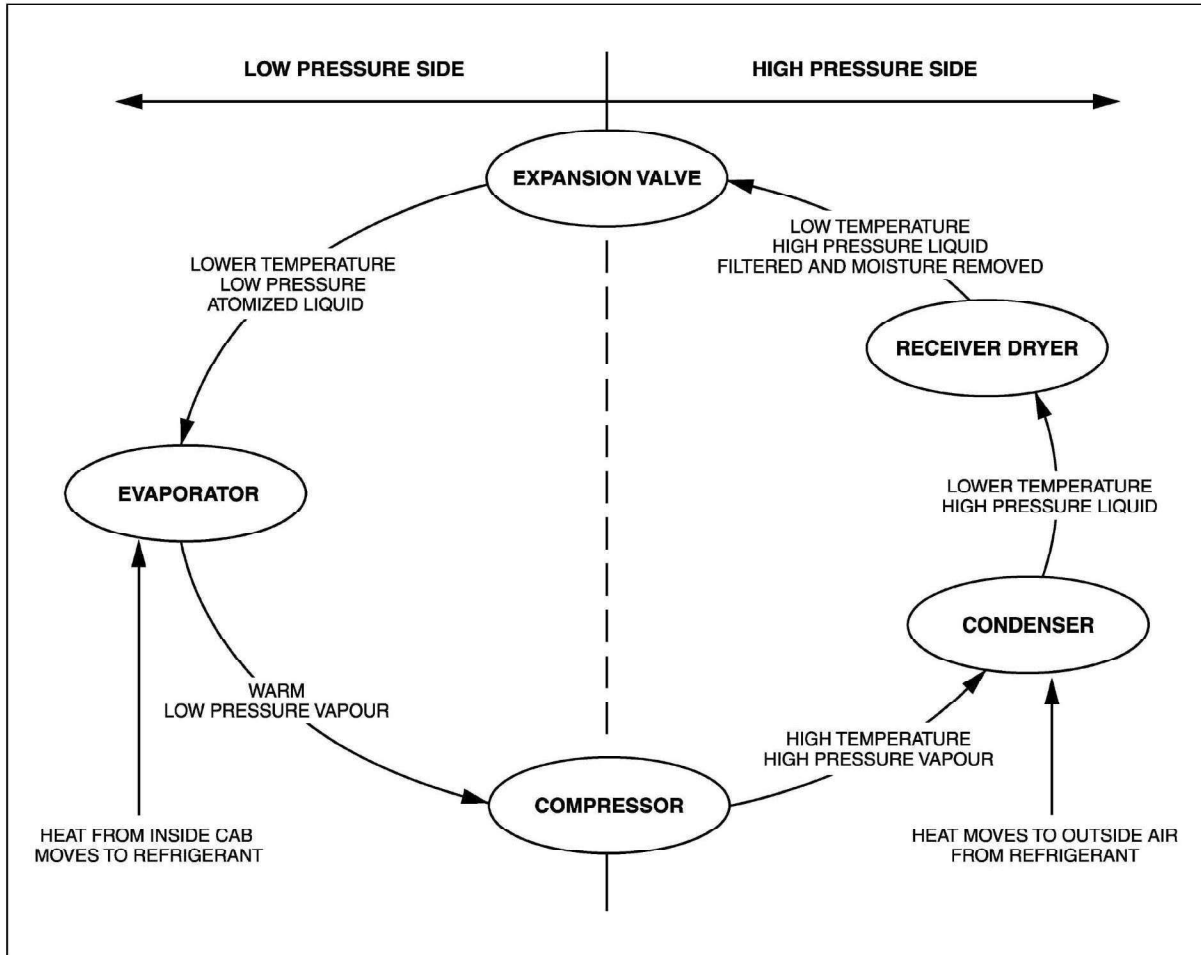

6

Air Conditioning Flow Diagram

Figure 6, shows in schematic form the flow of refrigerant through the five major components of an air conditioning system. Refer to, Figure 6, for the location of these components on the tractor.

Refrigerant is drawn into the compressor as a cool, low pressure vapor which is compressed and then pumped out as a hot, high pressure vapor to the condenser.

As the hot, high pressure vapor passes through the condenser core it gives off heat to the cooler outside air, being drawn past the fins by the engine cooling fan.

By giving off heat to the outside air, the vapor is condensed to a liquid which moves under high pressure to the receiver dryer where it is stored until released to the evaporator by the temperature sensing expansion valve.

As liquid refrigerant passes through the metered orifice in the expansion valve the refrigerant changes from a high pressure liquid to a low pressure atomized liquid with a lower temperature.

This low pressure, low temperature, atomized liquid enters the evaporator coils and absorbs heat from the cab warm air blown across the coils and fins by the cab blower motor. The refrigerant now changes from a cold low pressure atomized liquid to a warm low pressure vapor and leaves the evaporator outlet, moving to the suction (low pressure) side of the compressor to repeat the cycle.

As this heat loss is taking place, moisture (humidity) in the cab air will condense on the outside of the evaporator and drain off as water through the drain hoses attached to the evaporator drain pan, thereby reducing the humidity level of the cab.

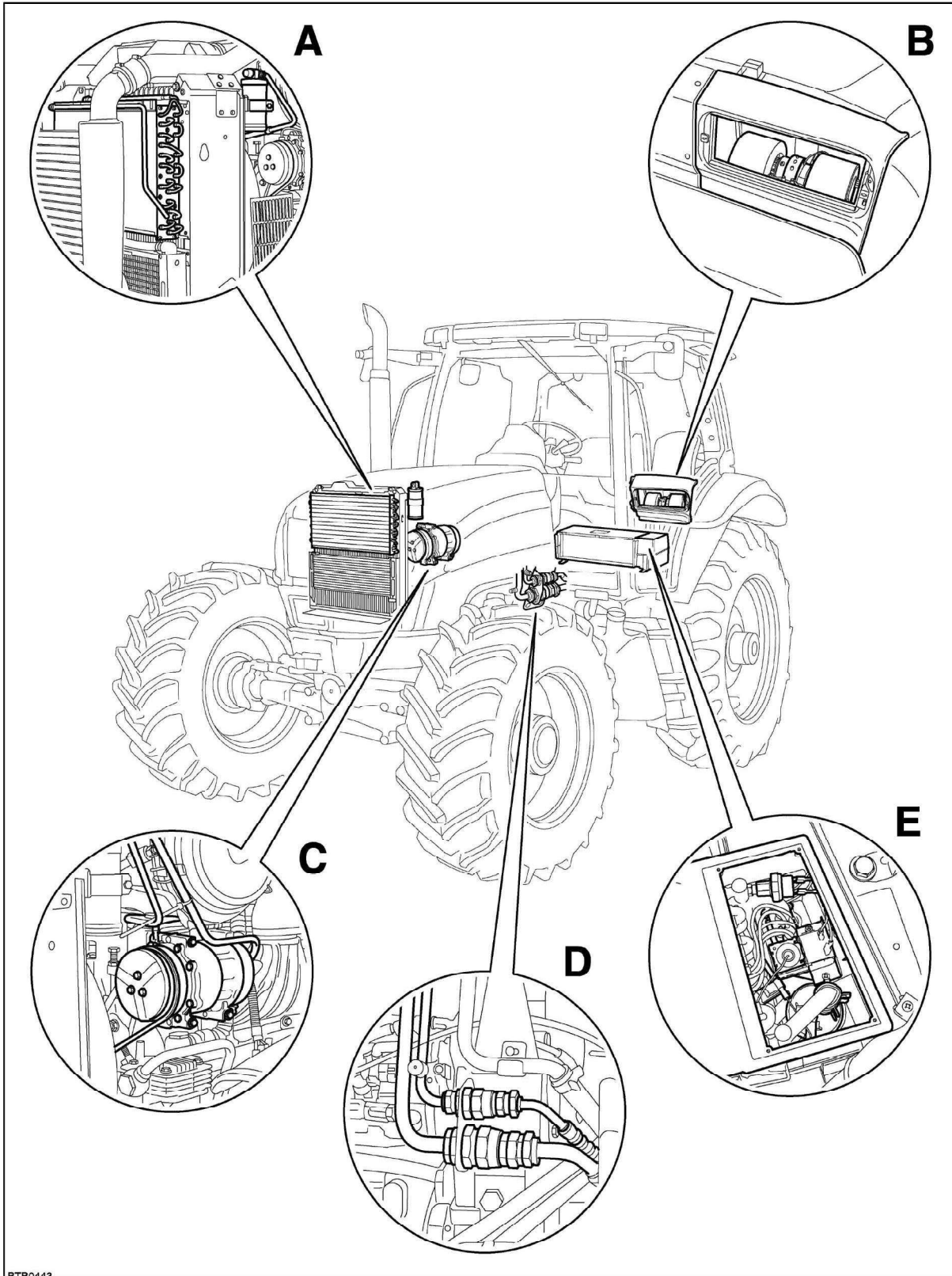

Air Conditioning Component Layout

A. Condenser and Receiver Dryer
 B. Blower Motor and Fan Assembly

C. Compressor
 D. Quick Release Self Sealing Couplings

E. Evaporator

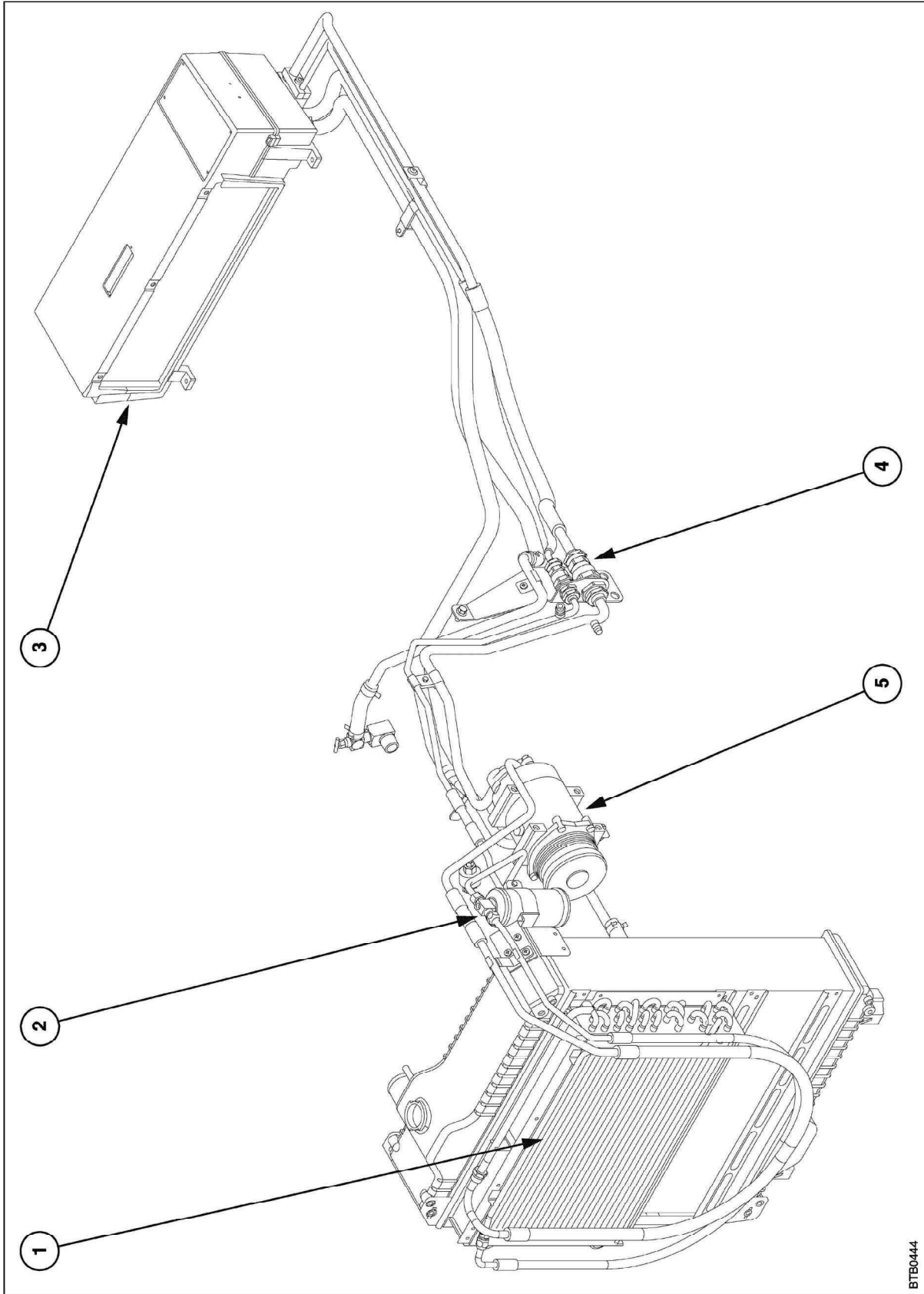

BTB0444

SYSTEM LAYOUT

1. Receiver Dryer
2. Condenser
3. Evaporator
4. Quick Release Self Sealing Couplings
5. Compressor

Refrigerant

To achieve the absorption and the release of heat which is, in essence, the function of an air conditioning system, requires the use of a suitable "refrigerant" - a liquid that has a relatively low temperature boiling point, plus certain desirable safety and stability features.

The refrigerant used in the air conditioning system is refrigerant R-134a.

NOTE: *To help protect the environment legislation has been introduced in most territories banning the release into the atmosphere of refrigerants, including R134a. All service procedures contained in this manual can be carried out without the need to release refrigerant into the atmosphere.*

In order to prevent the incorrect type of refrigerant being charged to the system the service valves fitted to the tractor and necessary to connect up refrigerant recovery, evacuation and recycling/recharging equipment will be of two different sizes as recognised and specified by the air conditioning industry.



WARNING



*R-134a refrigerant is **not compatible** with R-12 refrigerant. **Do not** attempt to replace R134a refrigerant with R-12 refrigerant or test the system using gauges or equipment previously used with R12 as damage to the system will result.*

R-134a refrigerant is stable at all operating temperatures and able to absorb great quantities of heat.

The boiling point of R-134a is -22° C (-15° F) at atmospheric pressure.

If the pressure is increased, R-134a will readily vaporize to absorb heat at temperatures between -11.7° C (11° F) at 1.9 bar (27.5 lbf/in²) and 0° C (32° F) at 42 lbf/in² (2.9 bar) in the evaporator.

At higher pressures, R-134a will condense and give off heat at temperatures between 48° C (118° F) at 12.4 bar (180 lbf/in²) and 58° C (136° F) at 15.85 bar (230 lbf/in²) in the condenser.

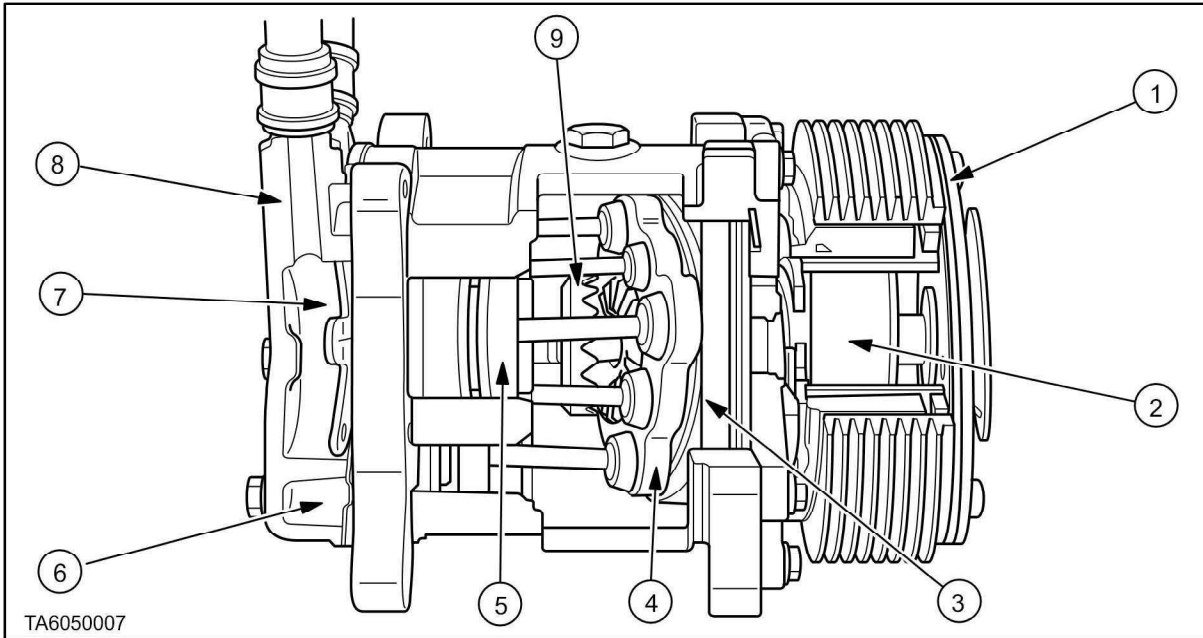

Air Conditioning Refrigerant Compressor

9

- | | |
|----------------------------|----------------------|
| 1. Electro-magnetic Clutch | 6. Suction Chamber |
| 2. Clutch Bearing | 7. Discharge Chamber |
| 3. Cam Rotor | 8. Cylinder Head |
| 4. Wobble Plate | 9. Static Gear |
| 5. Piston | |

Compressor Pump

The tractor air conditioning unit compressor pump is mounted on the left hand side of the engine and is belt driven by the crankshaft pulley, Figure 7.

The compressor separates the low and high pressure sides of the system and is basically a pump which has two functions:

- (1) To raise the refrigerant temperature by compression to a higher degree of temperature than the ambient (outside air) temperature.
- (2) To circulate the required volume of refrigerant through the system.

The refrigerant compressor is a seven cylinder wobble plate unit housed in a die cast aluminium housing.

Drive to the wobble plate is from the pulley, through the electro magnetic clutch to the main driveshaft. Attached to the driveshaft is a cam rotor which oscillates the wobble plate. The wobble plate is prevented from rotating by a static gear engaging with teeth formed in the face of the plate. The seven pistons are connected to the wobble plate by rods located in ball sockets.

Refrigerant is drawn in on the downward stroke of a piston through the reed valves located either end of the cylinder assembly. Refrigerant enters the cylinder assembly through a gallery in the outer circumference of the cylinder assembly.

The upwards stroke of the piston compresses the refrigerant and expels it through another reed valve into an inner gallery in the cylinder assembly and out into the refrigerant circuit.

The compressor is lubricated with a Polyalklene Glycol (PAG) oil. This oil is totally miscible with the refrigerant and is carried around the refrigerant circuit.

The compressor is activated by an electro-magnetic clutch which functions to engage or disengage the compressor as required in the operation of the air conditioning system.

The clutch is primarily activated by the:-

- Temperature cycling control switch
- Combined high/low pressure cut-out switch
- Low pressure cut-out switch

Low Pressure Cut-out Switch

The low pressure switch (1) Figure 10, is in the evaporator outlet line and is located under a lid in the evaporator housing under the rear floor.

The purpose of the switch is to shut off the compressor pump in the event of low pressure in the refrigerant system.

Low refrigerant pressure may occur due to a faulty expansion valve, icing up of the expansion valve orifice or refrigerant loss. Low refrigerant pressure may result in damage to the compressor pump.

The low pressure switch is factory set and cannot be adjusted.

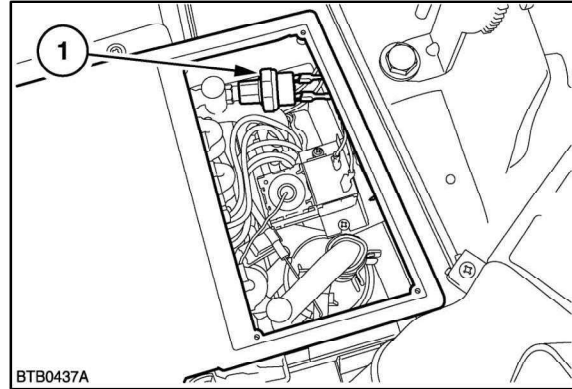

10

Combined High/Low Pressure Cut-out Switch

The combined high/low pressure switch, (1) Figure 11, is located in the condenser inlet line from the compressor. The switch shuts off the compressor pump in the event of a restriction in the high pressure line or excessively low pressure due to lack of refrigerant in the system.

Loss of refrigerant in the system will result in insufficient cooling and lubrication and continuous operation will cause damage to the compressor pump.

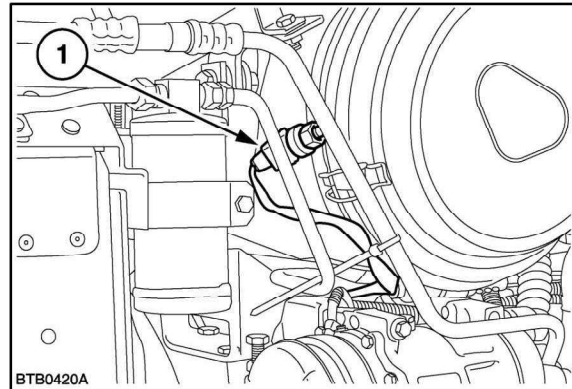

11

System Pressure Relief Valve

A relief valve is located at the discharge port on the compressor, (1) Figure 12. This allows the system refrigerant to be discharged into the engine bay (atmosphere) instead of in the cab, if the system pressure became such that a hose might fail in the cab and cause injury to the operator. This secondary safety feature will only operate in extreme conditions, for example, if the high pressure cut out switch were to fail, or in the event of an engine fire.

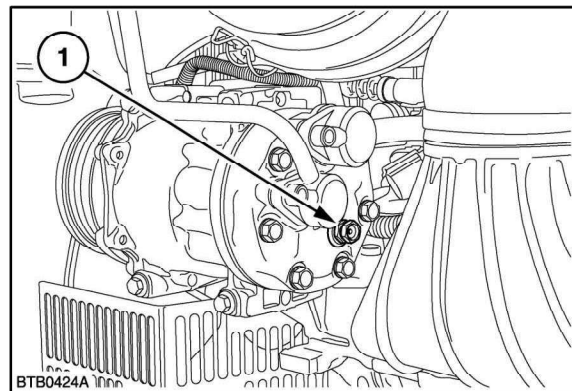

12

Condenser And Receiver Dryer

The condenser, (1) located at the front of the tractor, Figure 13, consists of a number of turns of continuous coil mounted in a series of thin cooling fins to provide a maximum of heat transfer in a minimum amount of space.

The condenser receives the hot, high pressure refrigerant vapour from the compressor. The hot vapour passes through the condenser coils and outside air is pulled through the condenser by the engine cooling fan.

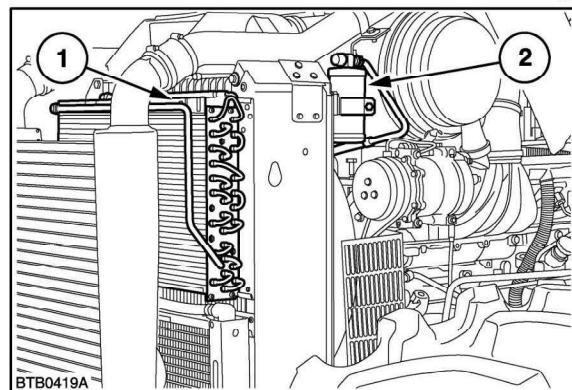

13

Heat moves from the hot refrigerant vapour into the cooler outside air flowing across the condenser coils and fins.

When the refrigerant vapour reaches the pressure and temperature that will induce a change of state, a large quantity of heat is transferred to the outside air and the refrigerant changes to a high pressure warm liquid.

The warm liquid refrigerant continues onto the receiver/drier where it is filtered and desiccated, to remove any moisture, before passing through an outlet line to the thermostatic expansion valve.

The receiver/dryer (2), Figure 13 stores the liquid refrigerant to be sure a steady flow to the thermostatic expansion valve is maintained under widely different operating conditions.

The drier section contains a desiccant (Molecular sieve) to absorb any moisture within the system and a filter prevents the entry of foreign particles.

NOTE: Any moisture in the air conditioning system is extremely harmful. Moisture not absorbed by the dehydrator will circulate with the refrigerant and droplets may collect and freeze in the thermostatic expansion valve orifice. This action will block the refrigerant flow and stop the cooling action. Moisture will also react with refrigerant R-134a and the lubricant to form a corrosive acid.

The desiccant can only absorb a limited amount of moisture before reaching saturation point. Because of this, after any system component replacement or repairs requiring entry into the system, the receiver/dryer should be replaced.

Expansion Valve

The expansion valve (1) Figure 14, is located next to the evaporator, in the pressure line leading from the receiver/dryer and performs the following functions:

1. **METERING ACTION** -
A metered orifice changes the liquid refrigerant from a high pressure low temperature liquid to a low pressure, lower temperature atomized liquid.
2. **MODULATING ACTION** -
A thermostatically controlled valve within the expansion valve body controls the volume of liquid refrigerant passing through the orifice and makes sure the refrigerant is fully vaporized within the evaporator. Liquid refrigerant would damage the compressor reed valves or freeze the pistons.
3. **CONTROLLING ACTION** -
The valve responds to changes in the cooling requirements. When increased cooling is required, the valve opens to increase the refrigerant flow and when less cooling is required the valve closes and decreases the refrigerant flow.

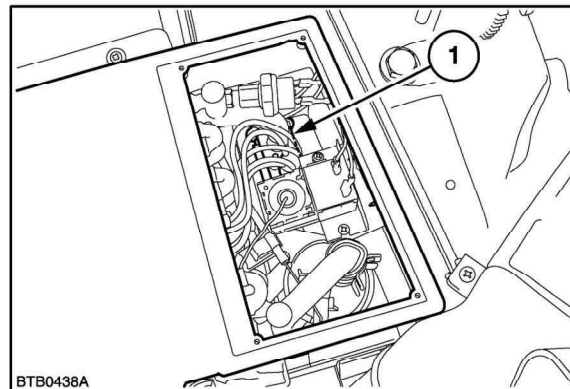

Expansion Valve - Operation

All of the needed temperature sensing and pressure sensing functions are consolidated into this basic unit and no external tubes are required for these purposes.

The refrigerant from the condenser and receiver dryer enters the thermostatic expansion valve as a high pressure warm liquid. Upon passing through the ball and spring controlled metering orifice, the pressure and temperature of the refrigerant is reduced and the refrigerant leaves the thermostatic expansion valve as a low pressure, lower temperature atomized liquid.

The atomized liquid now passes through the evaporator where it absorbs heat before returning via the expansion valve to the compressor as a warm Low pressure vapour.

There are two refrigerant passages in the valve. One passage is in the refrigerant line from the condenser to the evaporator and contains the ball and spring type orifice valve. The other passage is in the refrigerant line from the evaporator to the compressor and contains the valve's temperature sensing element.

Liquid refrigerant flow from the condenser and receiver dryer is controlled by a push-rod forcing the orifice valve ball off its seat and the spring exerting pressure on the ball to keep it on its seat.

During stabilized (vehicle shutdown) conditions, the pressure on the bottom of the expansion valve diaphragm rises above the pressure on the top of the diaphragm allowing the valve spring to close the orifice.

When the system is started, the pressure on the bottom of the diaphragm drops rapidly, allowing the orifice to open and meter atomized liquid refrigerant to the evaporator where it begins to vaporize.

Suction from the compressor draws the vaporized refrigerant out of the evaporator and back through a gallery in the top of the valve which passes the temperature sensor.

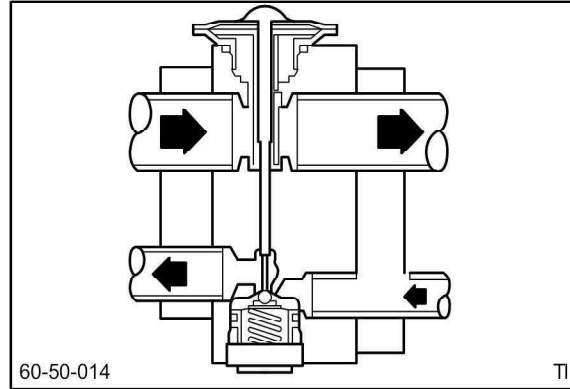

15

The temperature sensor reacts to variations in refrigerant gas pressure returning from the evaporator. When heat from the passenger compartment is absorbed by the refrigerant the pressure of the gas increases causing a differential pressure above and below the temperature sensor diaphragm. The diaphragm reacts to this pressure differential and a push rod forces the ball in the expansion valve orifice further off its seat. This reaction allows an increase in the atomized refrigerant to flow through the valve, to the evaporator, so that more heat can be absorbed by the air conditioning system.

Similarly when the temperature of the gas returning from the evaporator decreases the pressure of the gas decreases. This causes the diaphragm to react accordingly and allow the ball in the orifice to move closer towards its seat thus reducing the flow of refrigerant through the valve to the evaporator.

Evaporator

The evaporator, (2) Figure 16, is located under the rear seat floor and consists of a number of turns of continuous coils mounted in a series of thin cooling fins to provide a maximum of heat transfer in a minimum amount of space.

Low temperature refrigerant in the evaporator absorbs heat from the hotter air in the operator's compartment, thereby cooling the air.

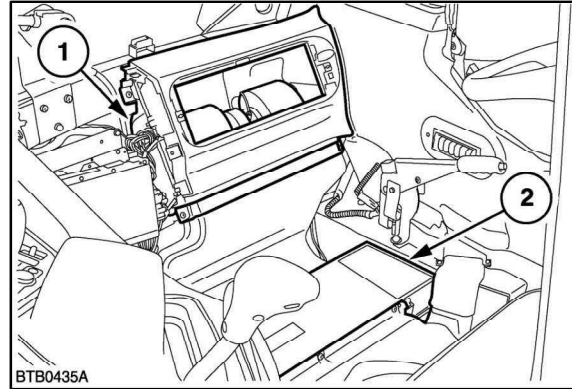

16

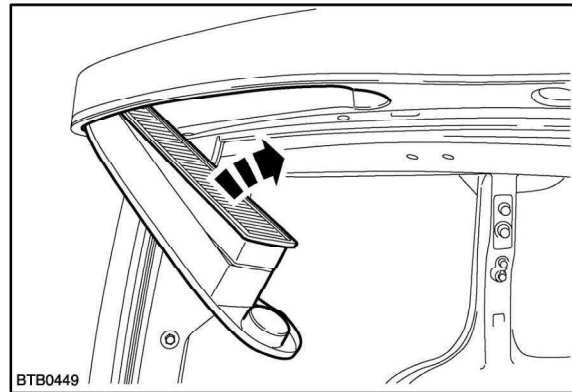

17

Blower Fan

The blower fan, (1) Figure 16, draws warm air from outside the cab through the intake filters, Figure 17 and forces it across the evaporator before entering the cab through louvered vents.

The blower motor is controlled by a four-speed switch (1), Figure 18. The switch uses a variable resistor to change the fan speed.

The coldest air will be obtained at the slowest fan speed but the greatest cooling capacity is obtained at the highest fan speed.

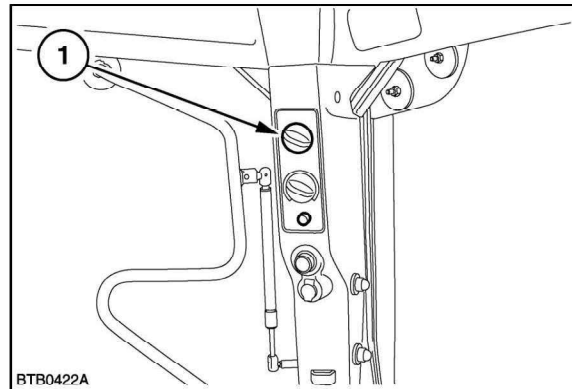

18

FAULT FINDING AND TESTING THE AIR CONDITIONING SYSTEM

General

Overhaul of the air conditioning system should only be undertaken by a certified specialist refrigeration engineer using a comprehensive air conditioning test kit, including a gas leak detector, suitable for R134a refrigerant gas.



*Before dismantling an air conditioning system for repair the gas within the system must be discharged and recovered using a **certified recovery unit** designed for the type of refrigerant gas used in the system.*

NEVER release refrigerant gas into the atmosphere.

ALWAYS wear safety goggles and gloves when servicing any part of the air conditioning system.

To prevent the entry of any foreign material, observe the following points:

- Ensure all tools, gauges, hoses and replacement parts are kept clean and dry and are suitable for the type of refrigerant gas used in the system.
- Clean all hoses and fittings before disconnecting. Cap or plug all openings when disconnected.
- When adding lubricating oil to the system always uncap and re-cap the oil container immediately before and after use. Always ensure the oil remains free of moisture.

Preliminary Fault Finding

Always conduct the preliminary fault finding checks before performance testing the system.

1. Run the engine at 1000-1200 rev/min for 10 minutes with the air conditioner set at maximum cooling and the blower on high speed.
2. Check that the heater temperature control is switched OFF.
3. Close the heater shut-off valve on the rear of the inlet manifold.
4. Check that the blower fan is operating at all speeds.
5. Check that the compressor clutch engages when the air conditioning switch is pressed in. A clicking sound indicates the clutch is engaging. If the clutch fails to operate it may indicate an electrical problem in the high or low pressure cut out switches or malfunction of the electric drive clutch on the compressor.
6. Check the engine cooling fan is drawing cool air through the condenser
7. Check the compressor drive belt tension.
8. Check the condenser core and grid is clean and free of obstruction.
9. Check the cab air filters are clean and free of obstruction.
10. Check the evaporator fins are not plugged or excessively dirty.

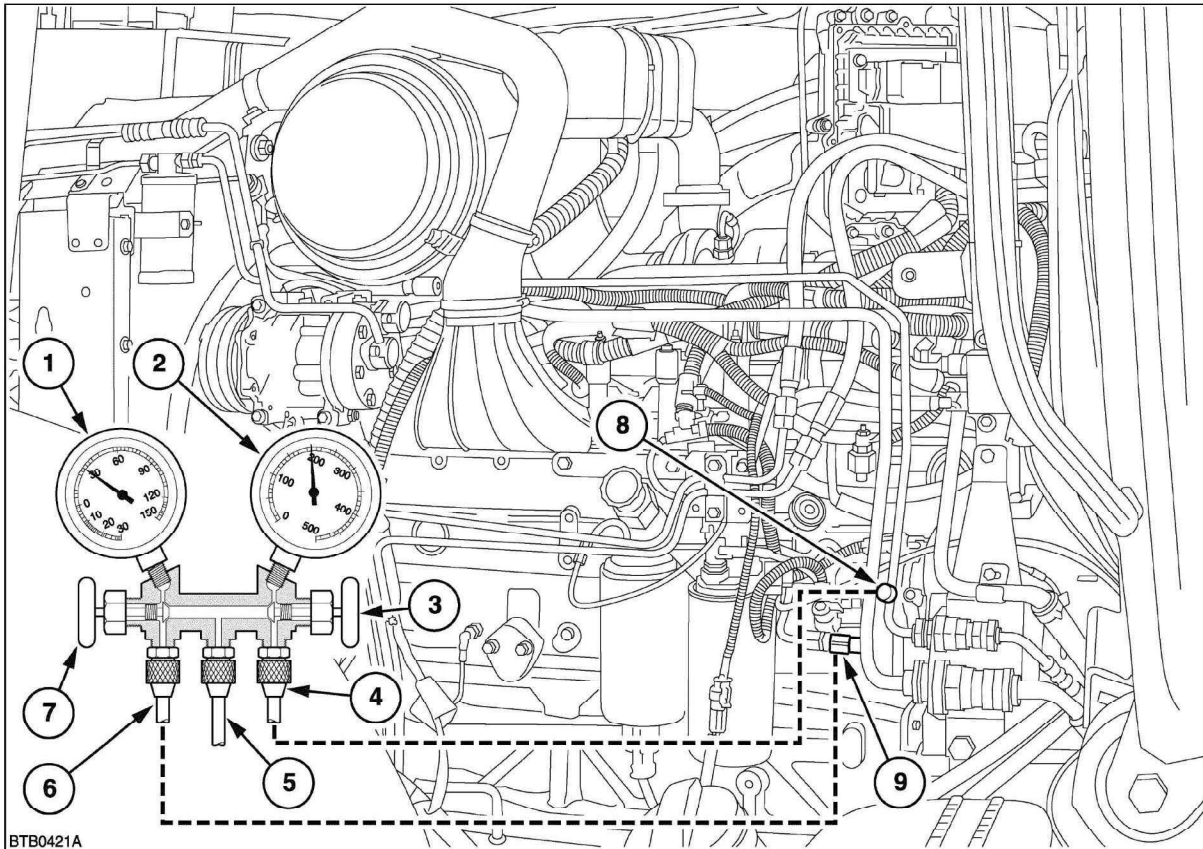

Attaching Manifold Gauge Set to the Tractor

19

- | | |
|--|--|
| <ol style="list-style-type: none"> 1. Low Side Gauge 2. High Side Gauge 3. Shut-off Valve 4. Test Hose to High Side Service Connector 5. Center Hose (Not Used) | <ol style="list-style-type: none"> 6. Test Hose to Low Side Service Connector 7. Shut-off Valve 8. High Pressure Side Service Valve 9. Low Pressure Side Service Valve |
|--|--|

Performance Testing The Air Conditioning System

The manifold gauge set is the most important tool used in testing and servicing the air conditioning system.

It should be noted however that for those dealers who possess the latest design level of refrigerant recovery, recycling and recharging station these gauges are an integral part of the machine.

The following instructions for performance testing the air conditioning system is based on the use of the gauge set shown in Figure 19. The principal of operation is however similar when testing the system using a recovery and recharging station with integral gauges.

When using this type of equipment **always** consult the manufacturers operating instructions.

Operating Precautions

IMPORTANT: Always ensure the shut-off valves are **closed** (turn clockwise until seated) during all test operations.

In the closed position, refrigerant circulates around the valve stems to the gauges. Therefore, when the manifold gauge set is connected into a system, pressure is registered on both gauges.

- **NEVER** open the HIGH SIDE shut off valve when the system is operating.
- **ALWAYS** open the LOW SIDE shutoff valve when adding refrigerant.