

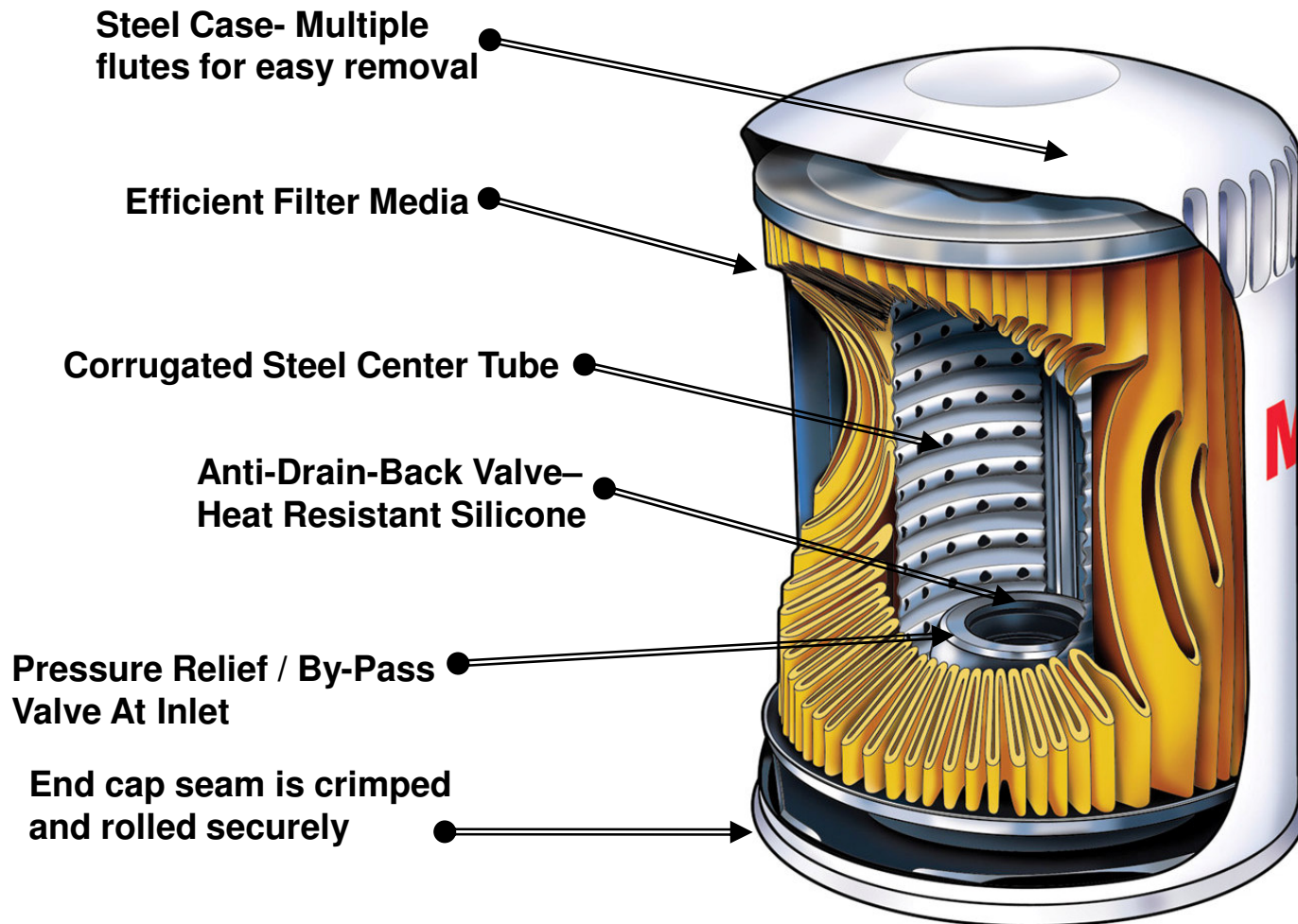

# **Oil Filter Cut-Away Comparison Kit**

# Motorcraft Oil Filter Construction



# Motorcraft Features & Benefits

<b>Motorcraft Oil Filters</b>	<b>Aftermarket Oil Filters</b>
<p><b><u>Pressure Relief Valves</u></b></p> <ul style="list-style-type: none"><li>○ Feature an up-front (threaded-end) pressure relief valve design which prevents unfiltered oil from reaching the engine</li></ul> <p><b><u>Anti-Drain Back Valve</u></b></p> <ul style="list-style-type: none"><li>○ Top selling Motorcraft oil filters utilize silicone rubber anti-drain back valves for higher heat resistance</li></ul> <p><b><u>Center Tubes</u></b></p> <ul style="list-style-type: none"><li>○ Corrugated steel center tubes that withstand pressure surges and prevent leakage</li></ul> <p><b><u>Quality Construction</u></b></p> <ul style="list-style-type: none"><li>○ Motorcraft filters have well-bonded end plates and consistent pleat spacing</li><li>○ High-quality steel case and base</li></ul> <p><b><u>Media Area</u></b></p> <ul style="list-style-type: none"><li>○ Filter media is formulated to meet Ford OEM requirements and media area is larger for optimal efficiency and capacity</li><li>○ Pleat number and height equate to more filtering surface area and greater filtering capacity</li></ul>	<p><b><u>Pressure Relief Valves</u></b></p> <ul style="list-style-type: none"><li>○ Many aftermarket filters use a dome-end design relief valve which may allow unfiltered oil into the engine</li></ul> <p><b><u>Anti-Drain Back Valve</u></b></p> <ul style="list-style-type: none"><li>○ Many aftermarket anti-drain back valves are constructed of nitrile rubber that can become brittle over time when exposed to hot oil</li></ul> <p><b><u>Center Tubes</u></b></p> <ul style="list-style-type: none"><li>○ Many aftermarket filters have plastic center tubes</li></ul> <p><b><u>Quality Construction</u></b></p> <ul style="list-style-type: none"><li>○ Some aftermarket filters are not well bonded, allowing unfiltered bypass</li><li>○ Some aftermarket filters may use lower-quality steel case</li></ul> <p><b><u>Media Area</u></b></p> <ul style="list-style-type: none"><li>○ Aftermarket filter media is not designed to meet Ford's requirements and the media area is typically smaller</li></ul>

# Motorcraft Design Advantages

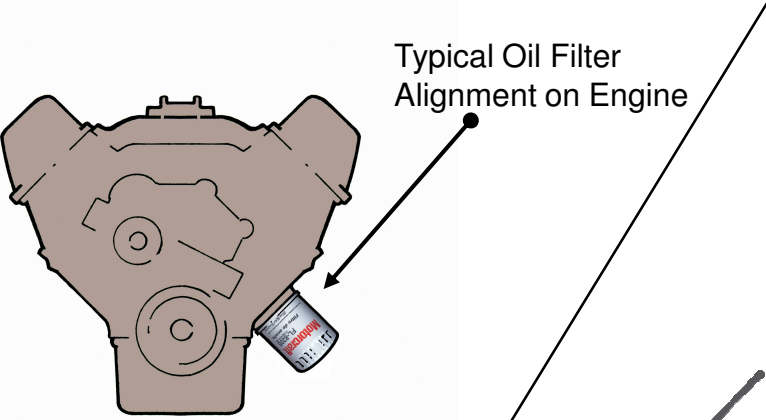

## Aftermarket

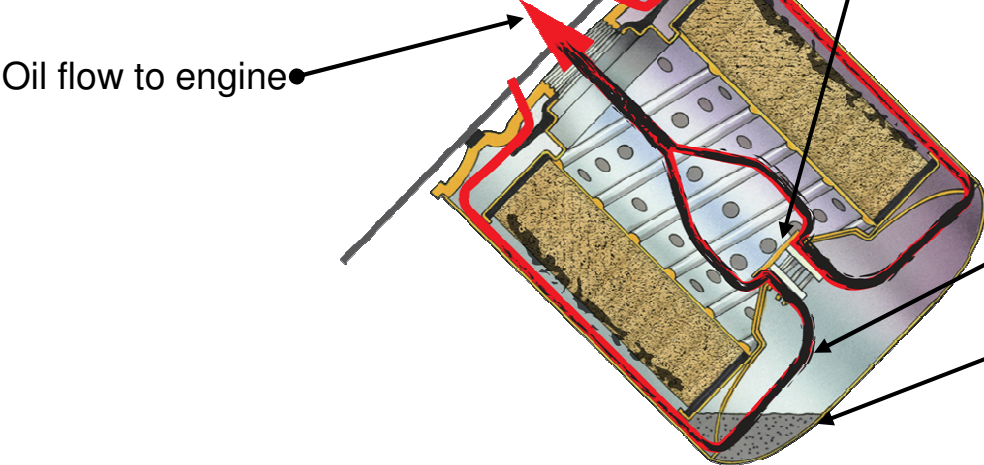

## FL-820S

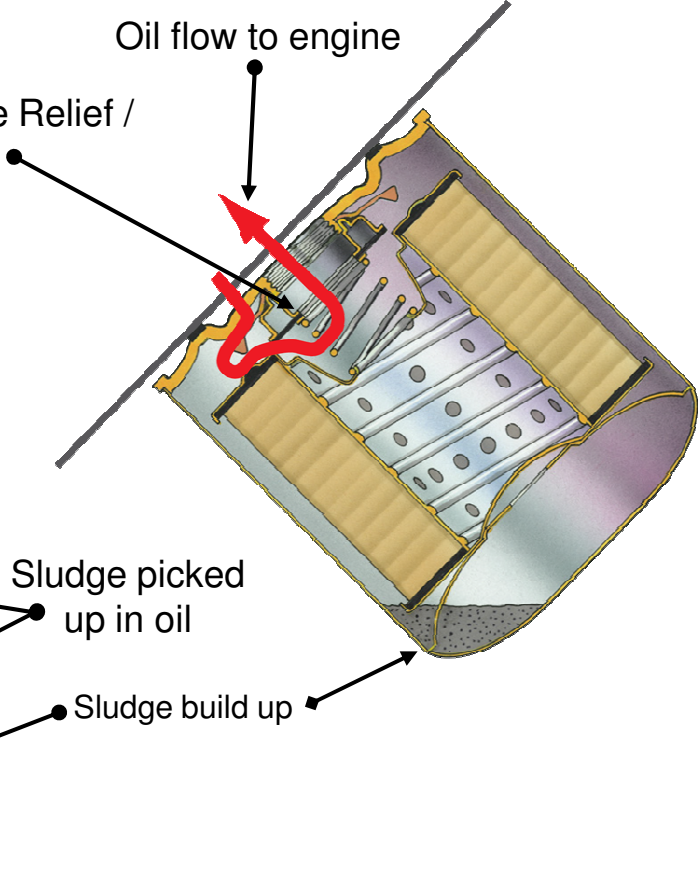

# Motorcraft vs. Pennzoil

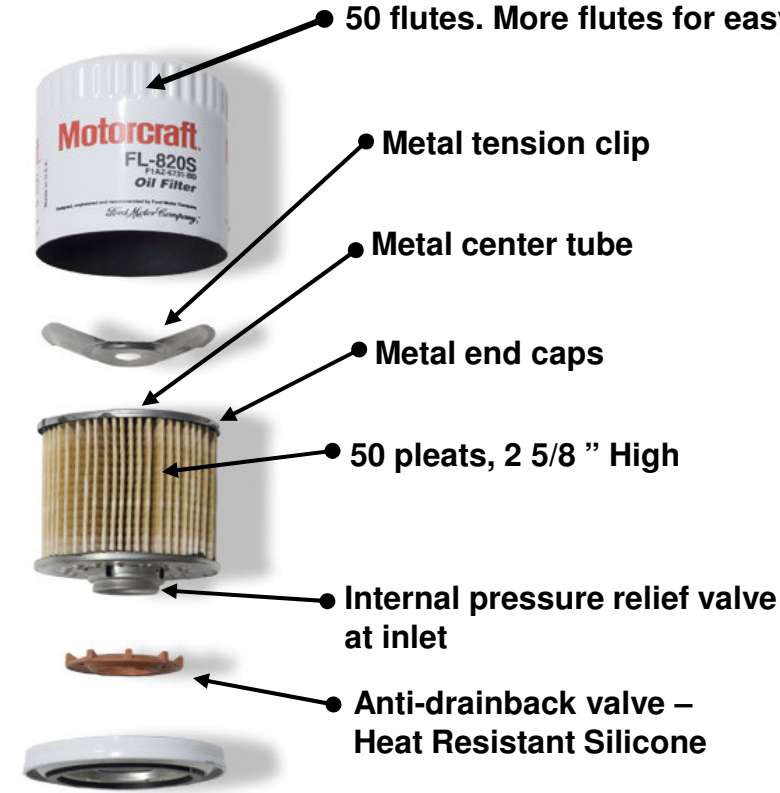

**FL-820S**

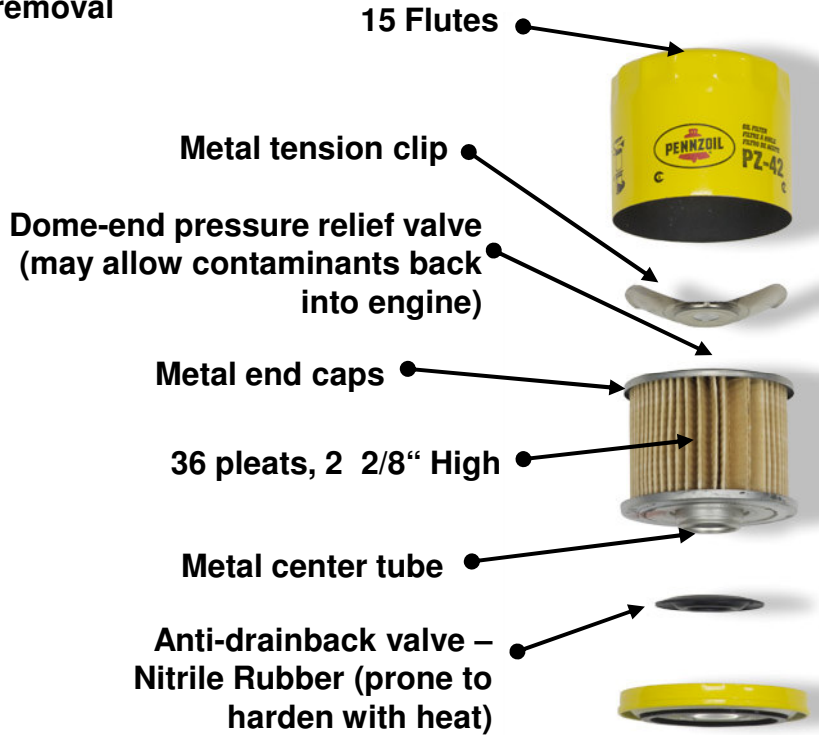

**PZ-42**

# Motorcraft vs. Fram

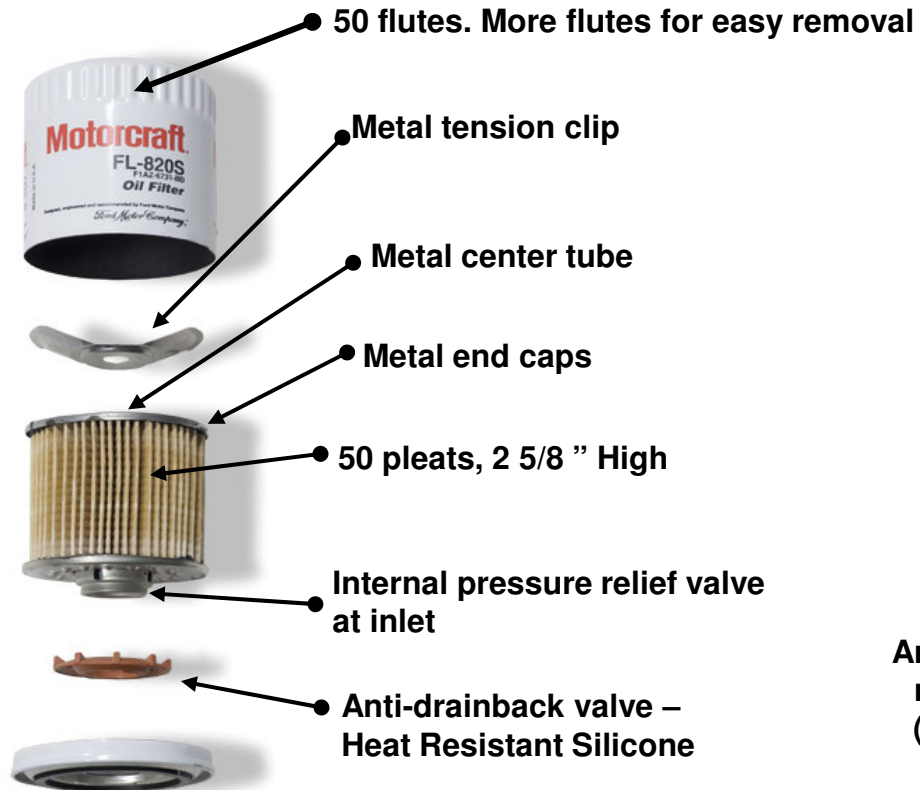

**FL-820S**



**PH-2**

# Motorcraft vs. Bosch

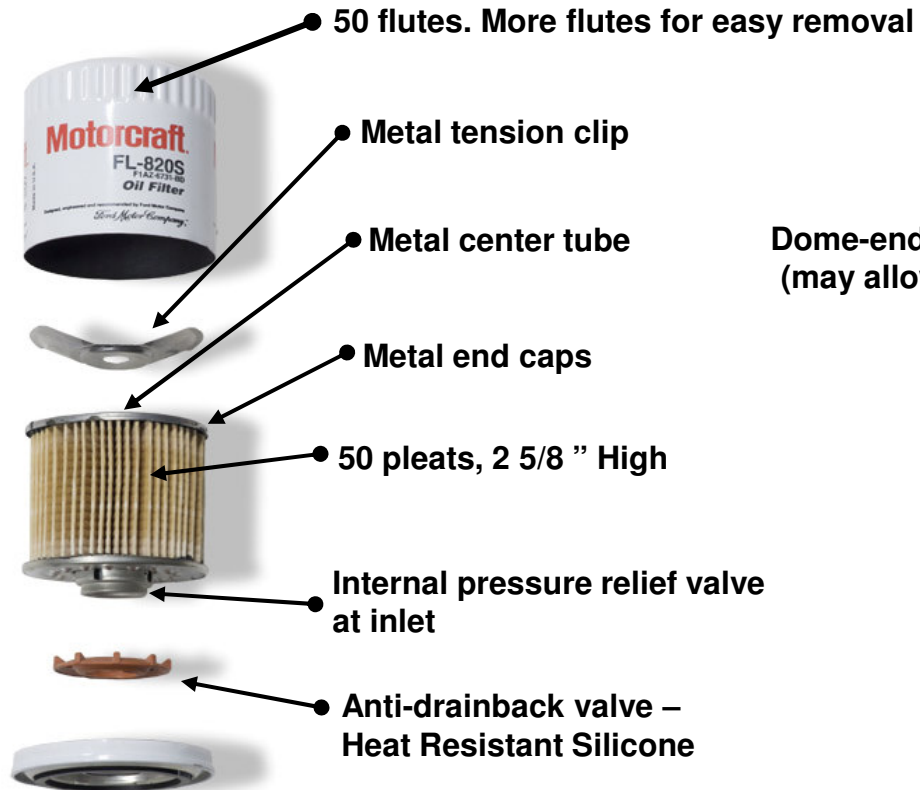

**FL-820S**

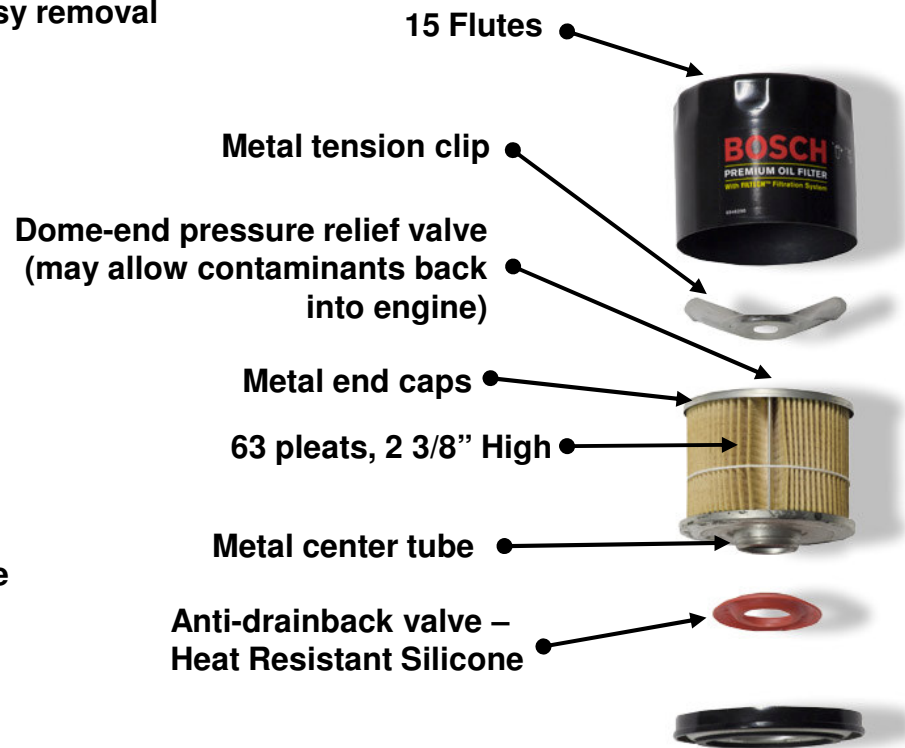

**#3410**

# Motorcraft vs. Champ

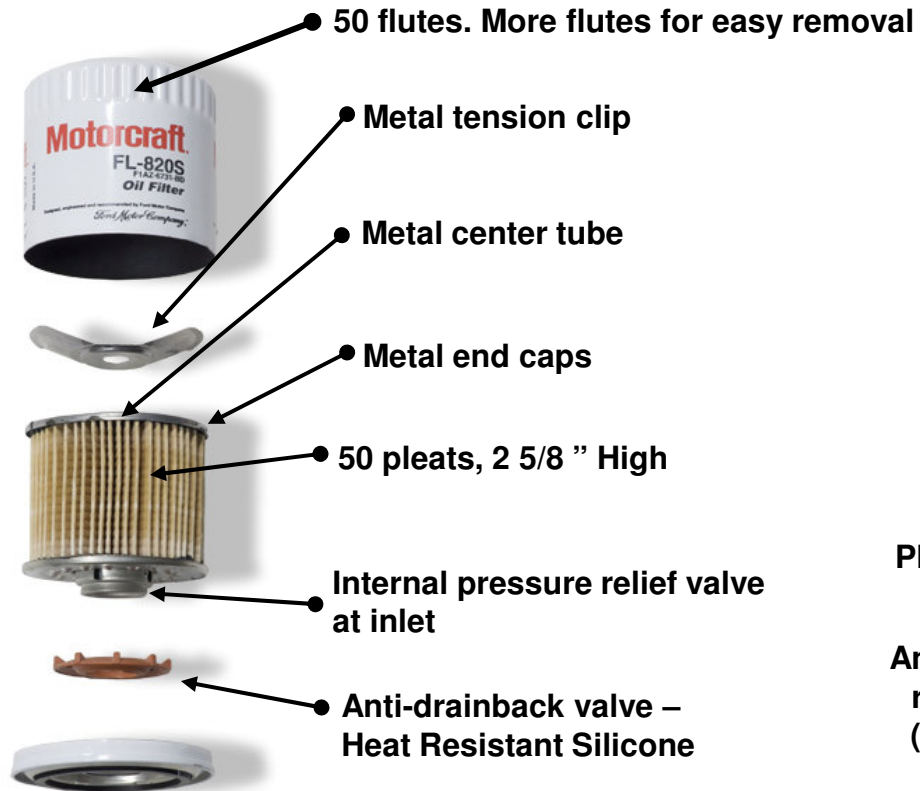

**FL-820S**

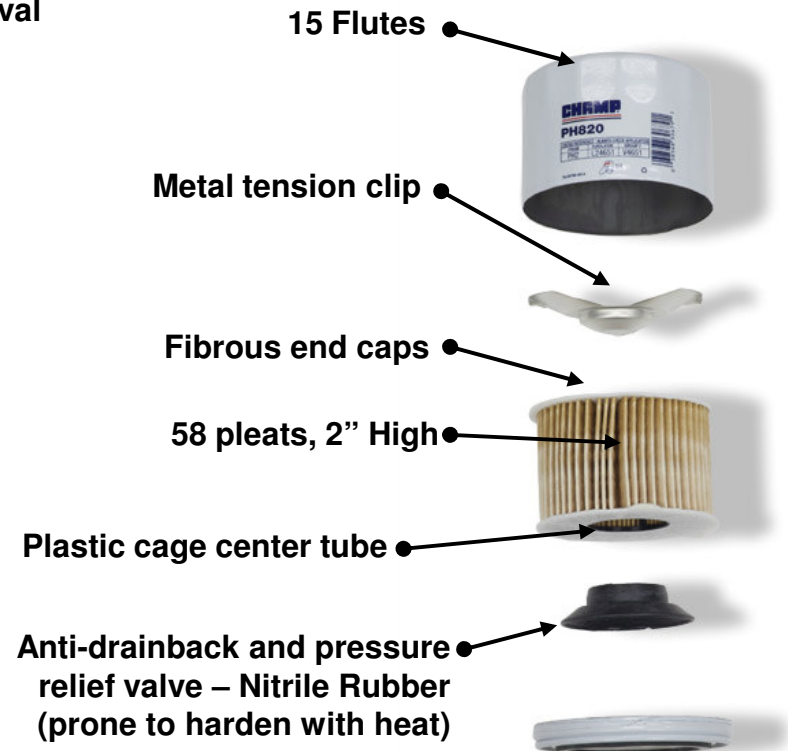

**PH-820**

# Motorcraft vs. AC-Delco

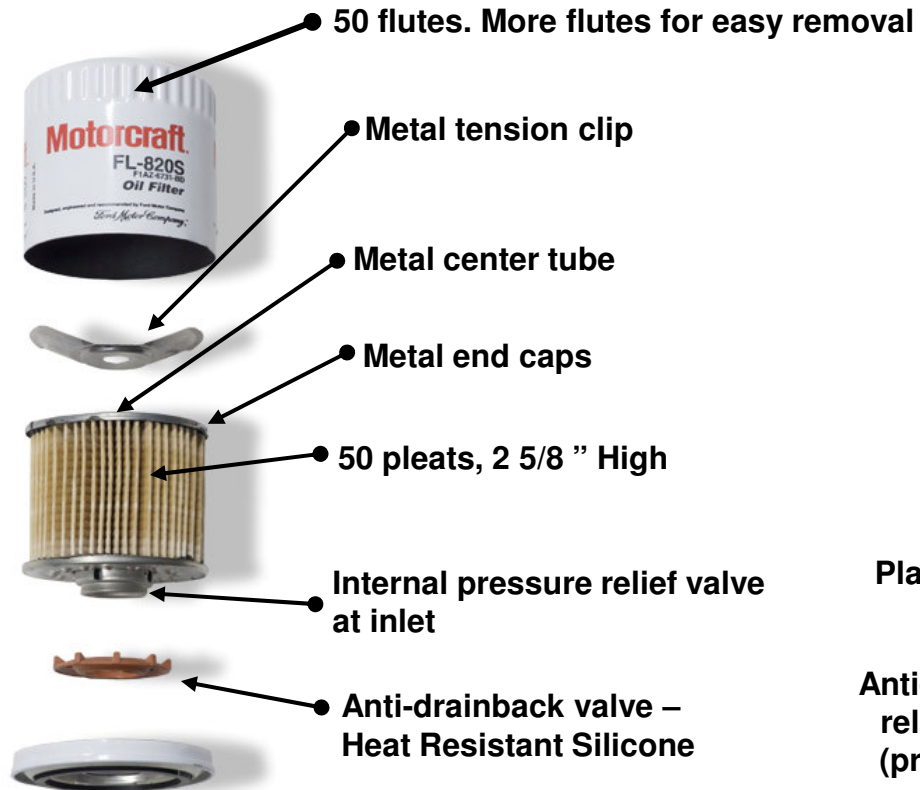

**FL-820S**

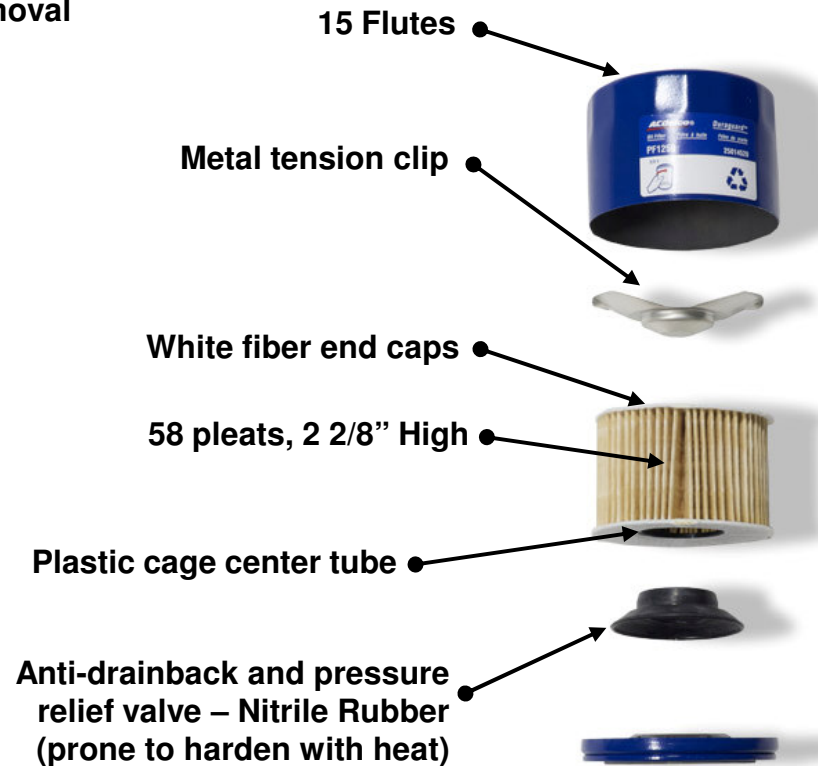

**PF-1250**

# Motorcraft vs. Valvoline

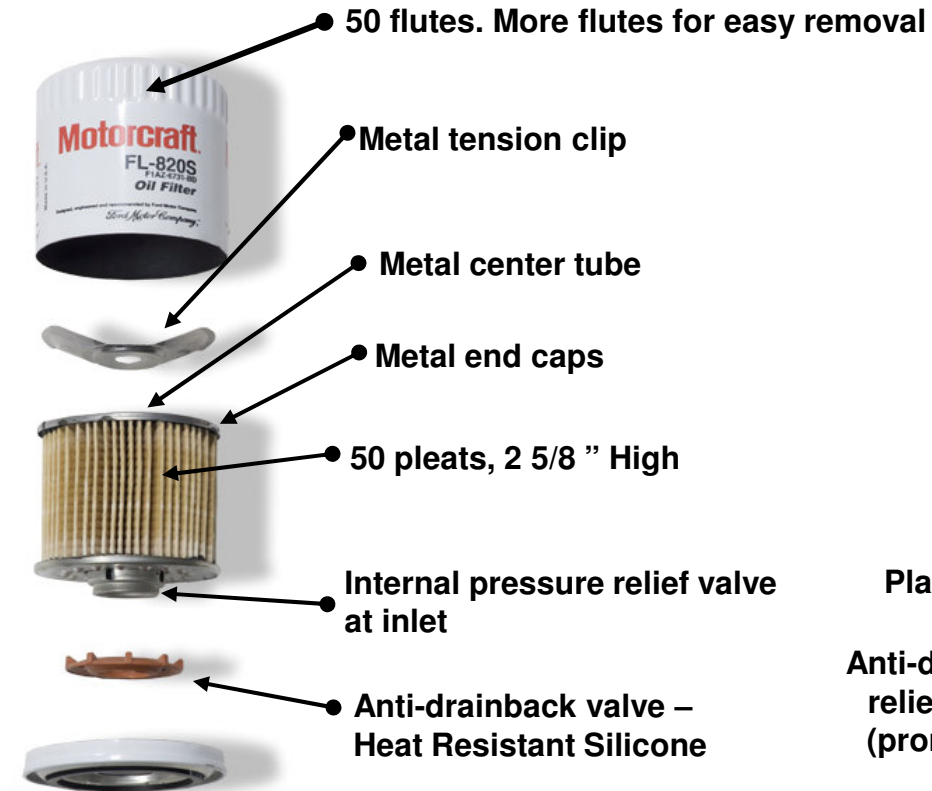

**FL-820S**

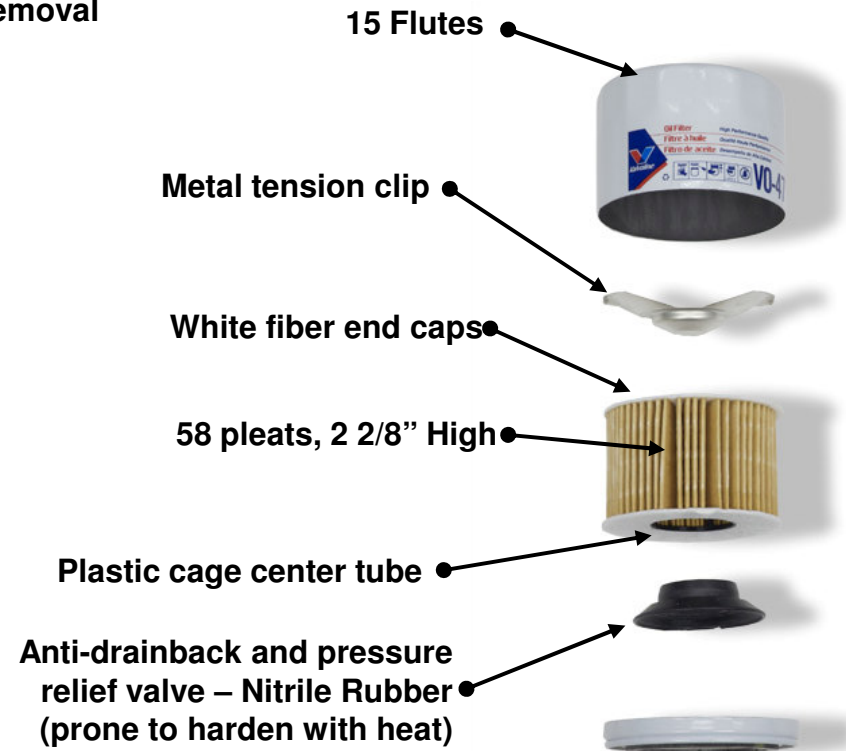

**VO-47**

# Motorcraft vs. STP

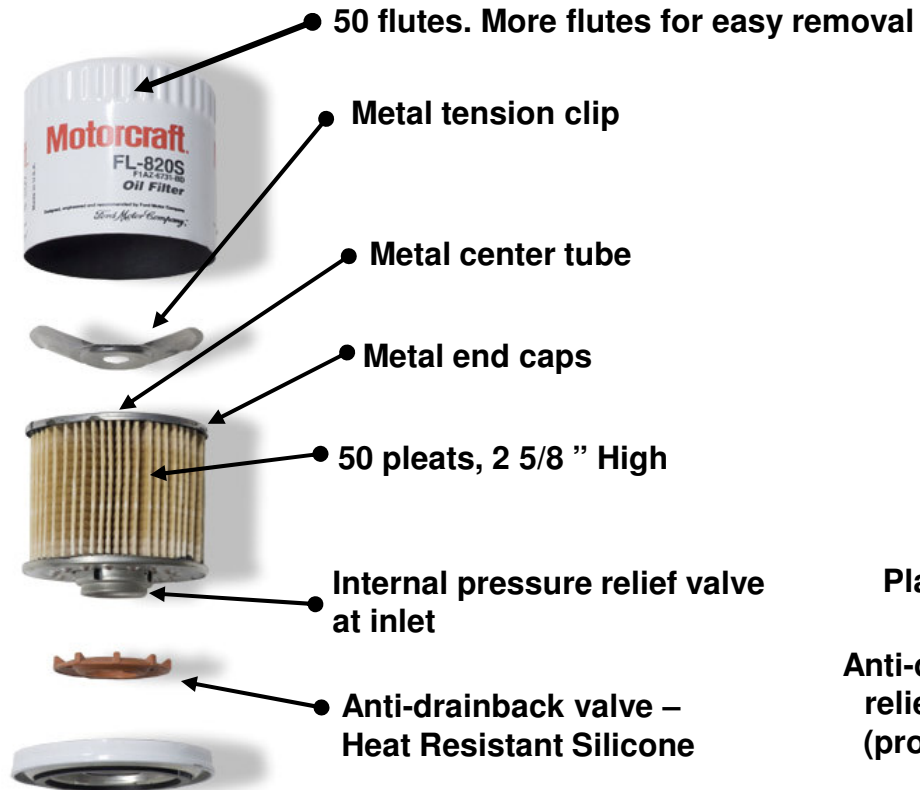

**FL-820S**

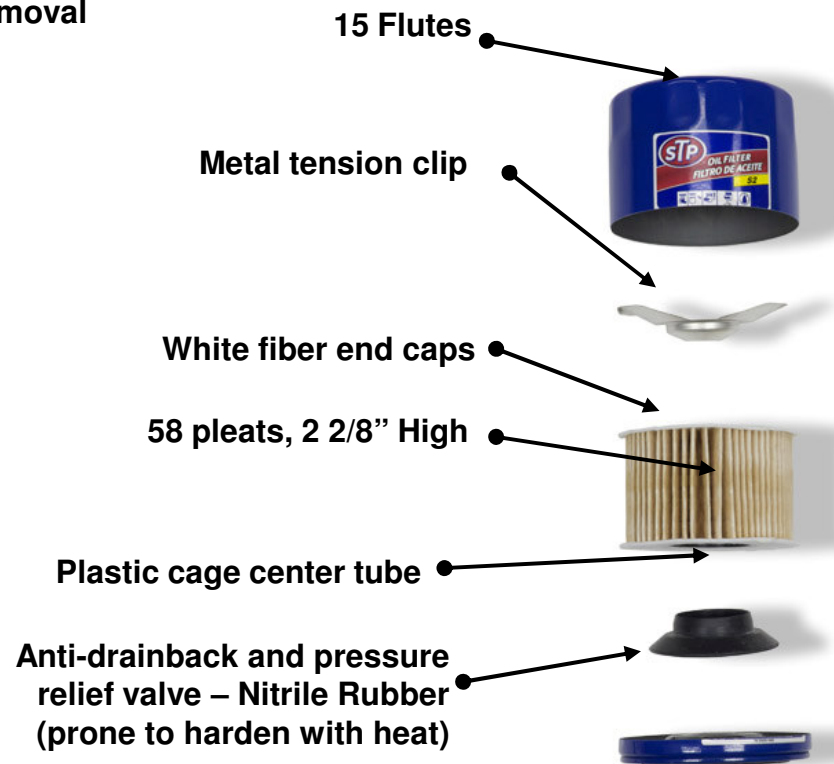

**S-2**

# Motorcraft vs. Mighty

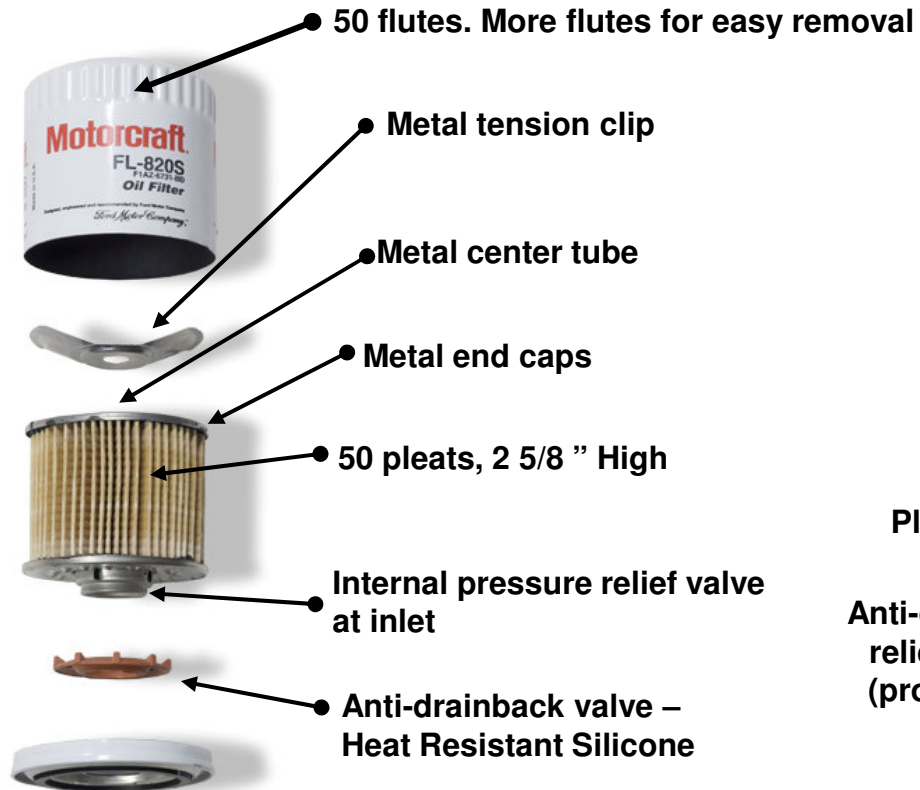

**FL-820S**

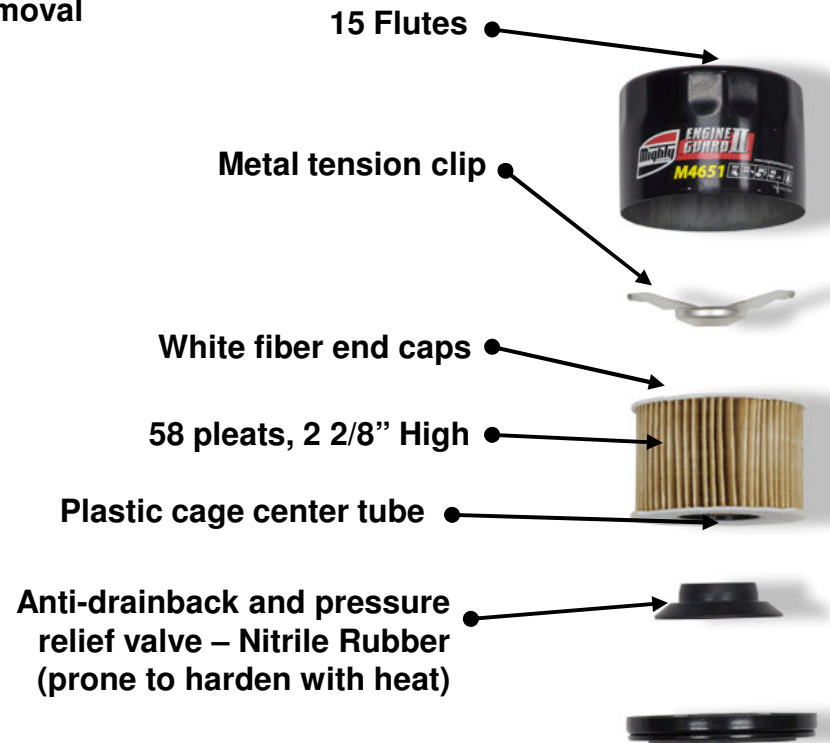

**M-4651**

# Motorcraft vs. ProLine

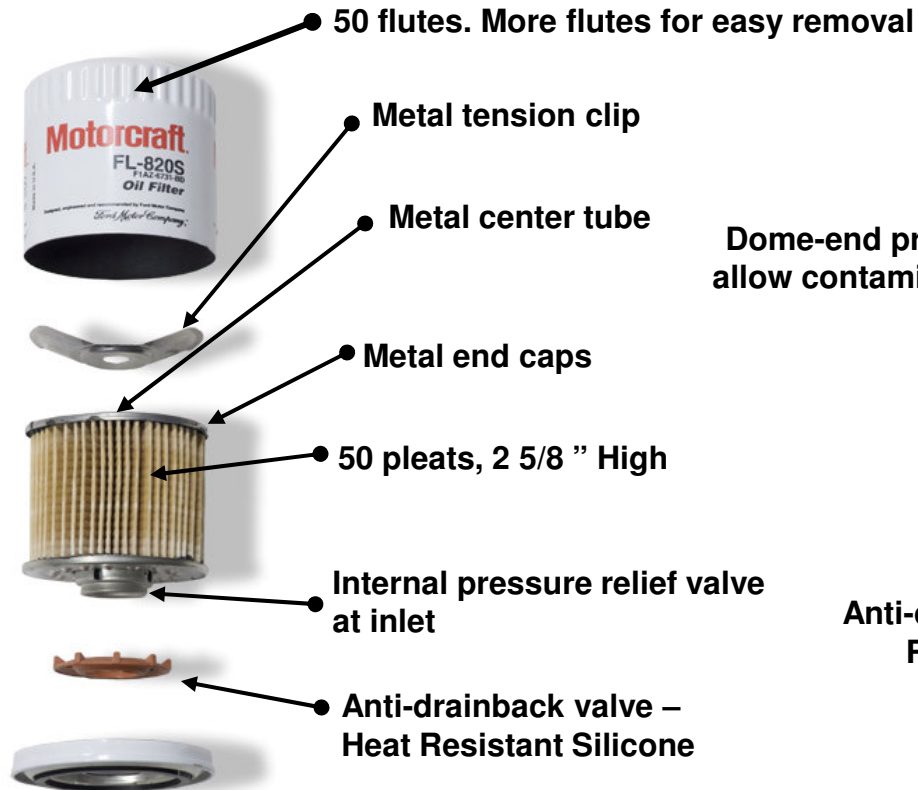

**FL-820S**

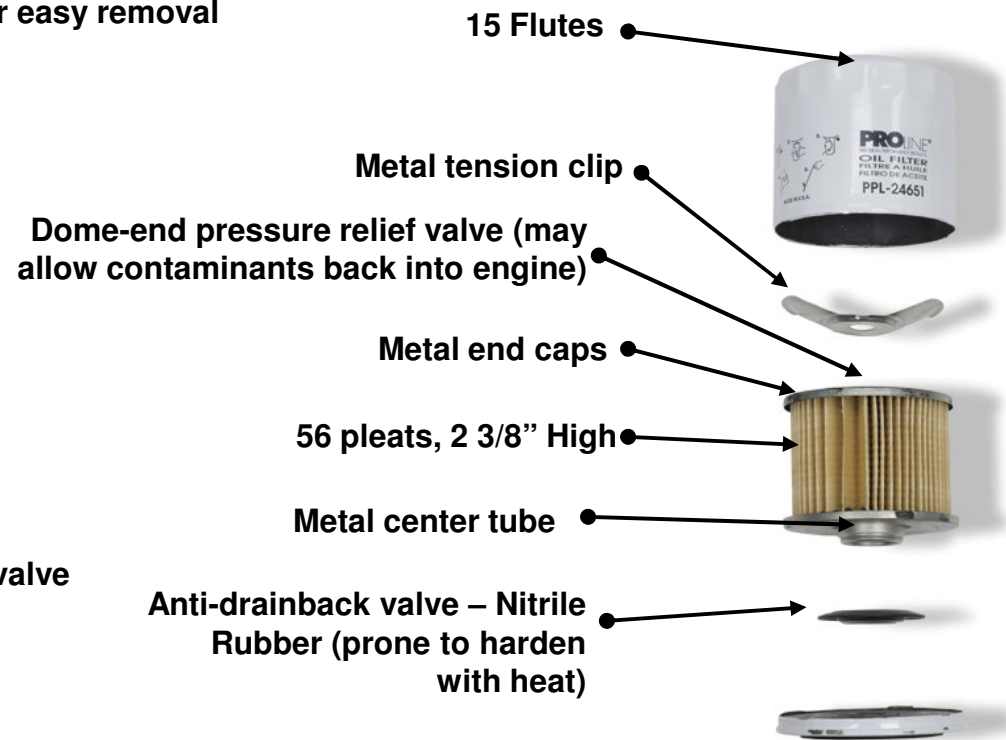

**PPL-24651**

# Motorcraft vs. Fleetguard

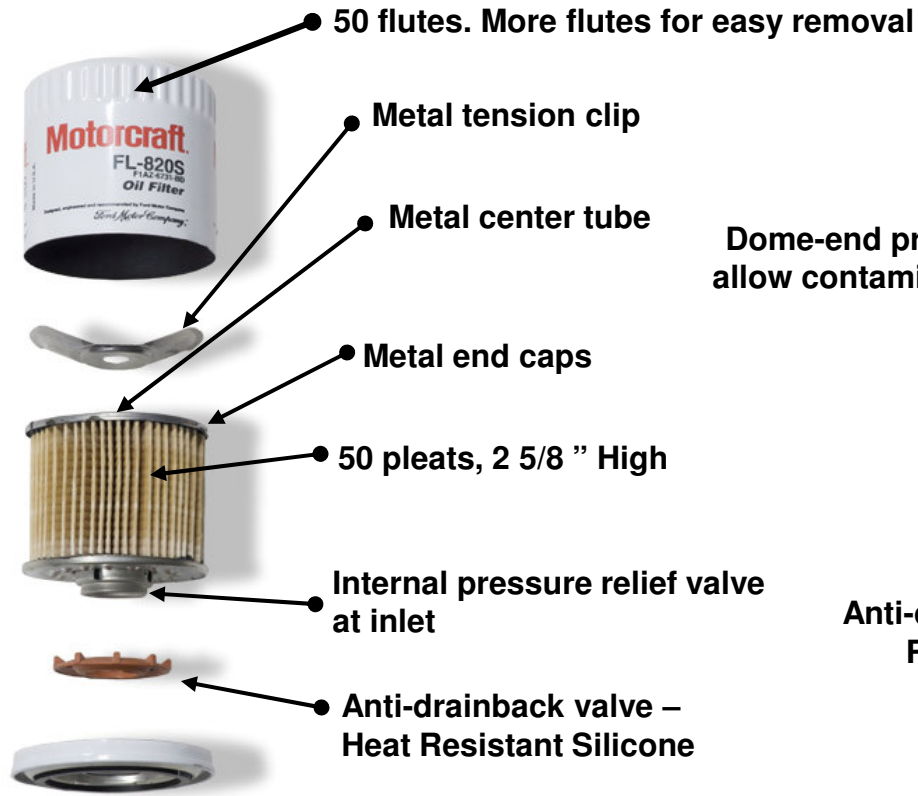

**FL-820S**

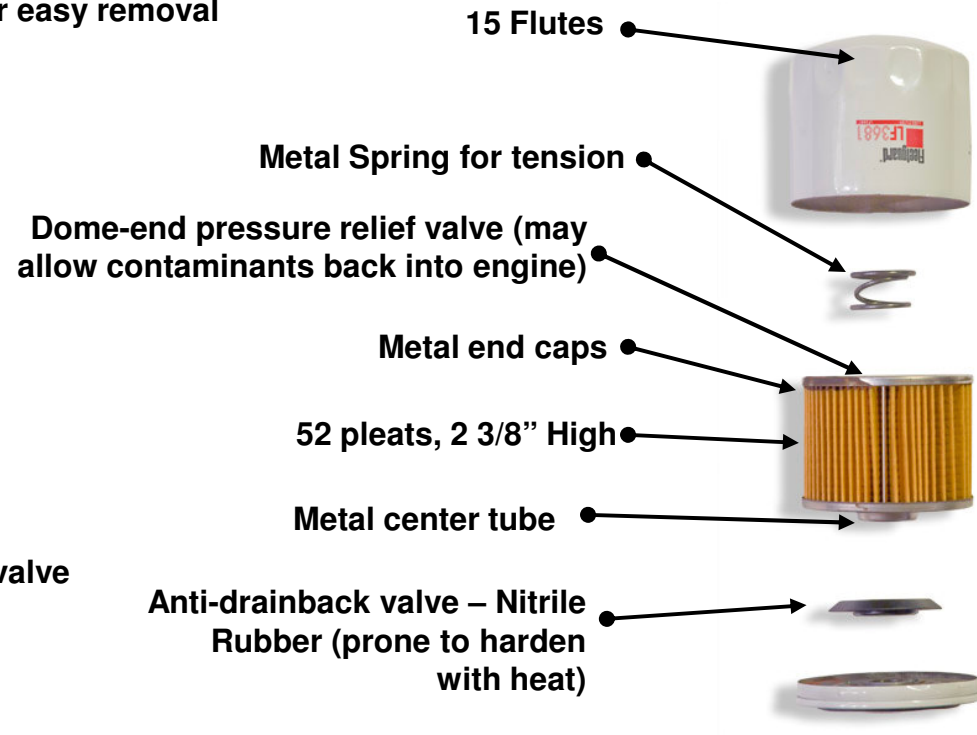

**LF-3681**

# Motorcraft vs. Mobil 1

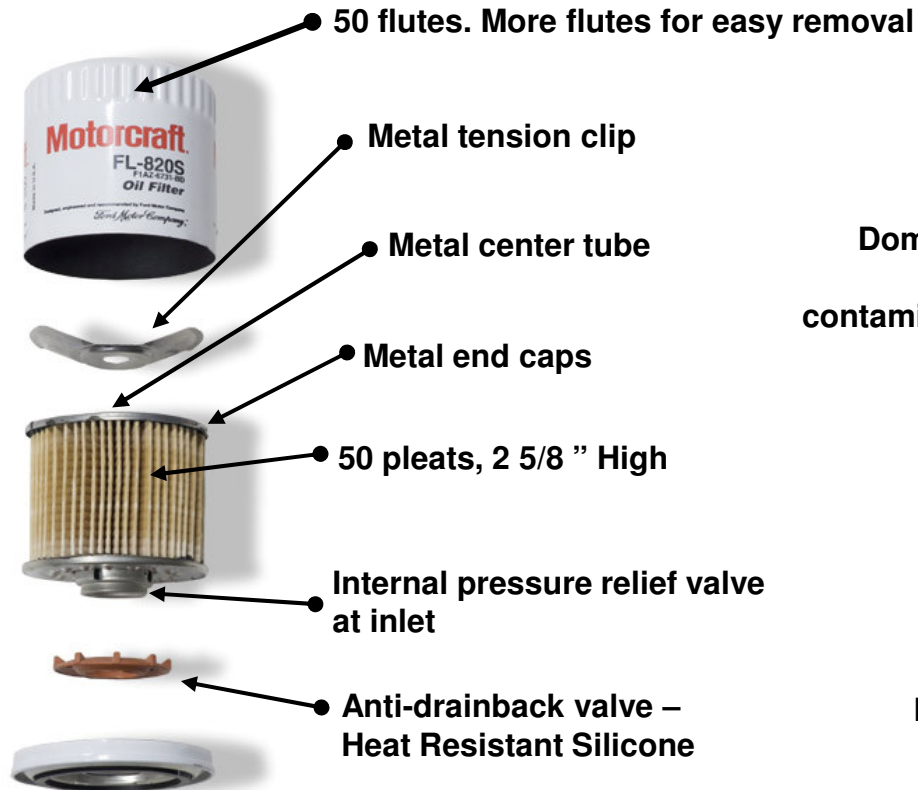

**FL-820S**

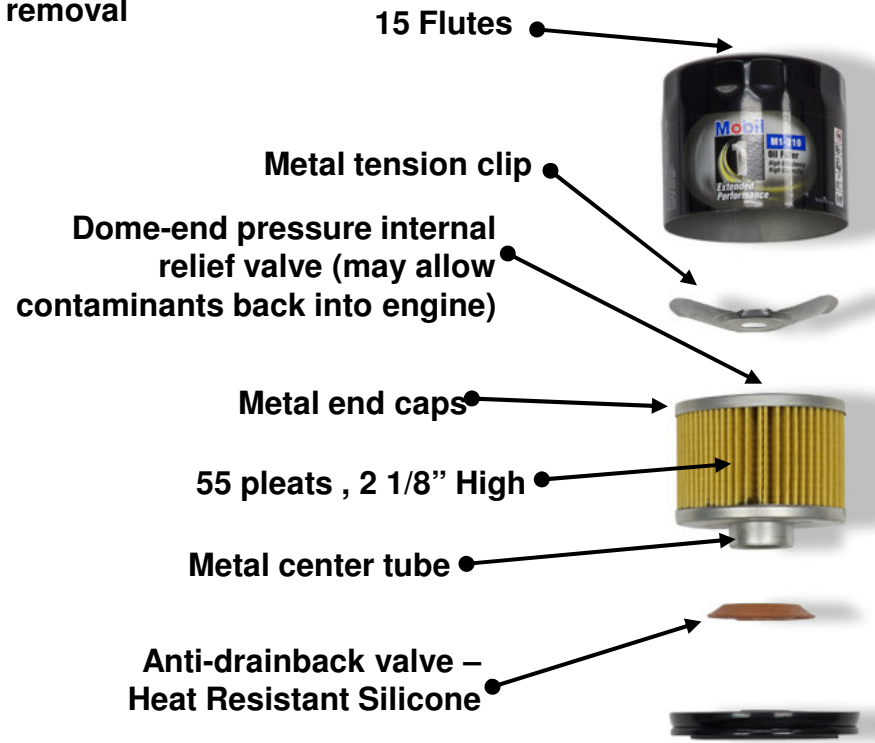

**M1-210**

# Motorcraft vs. K & N

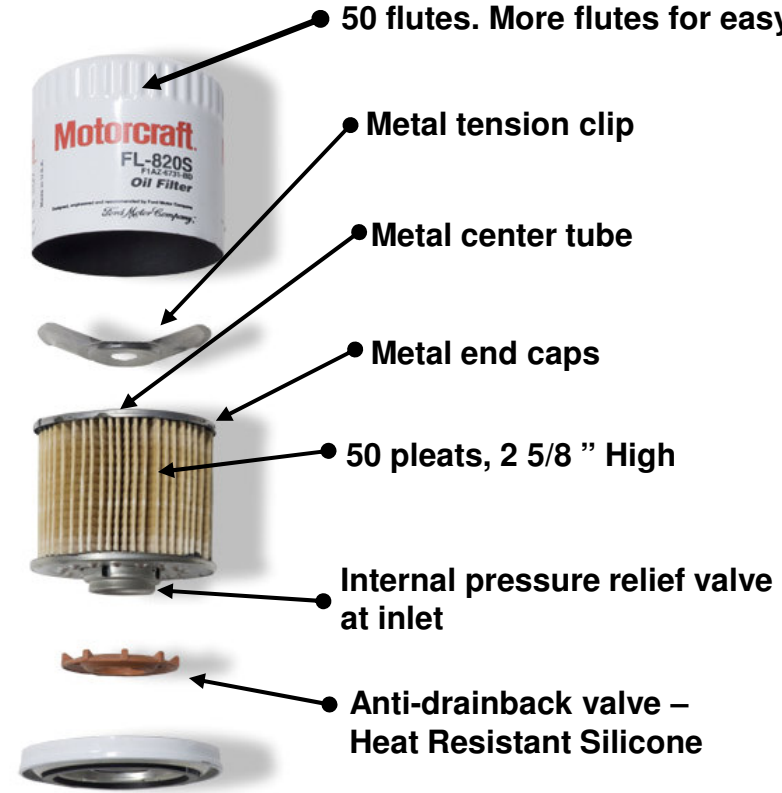

**FL-820S**

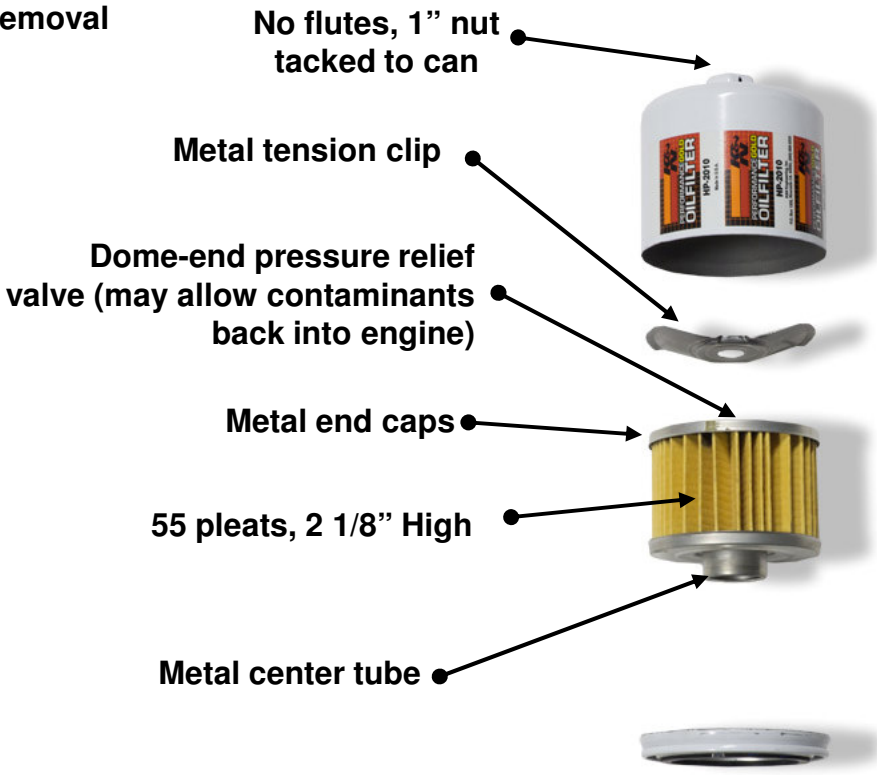

**HP-2010**

# Motorcraft vs. Wix

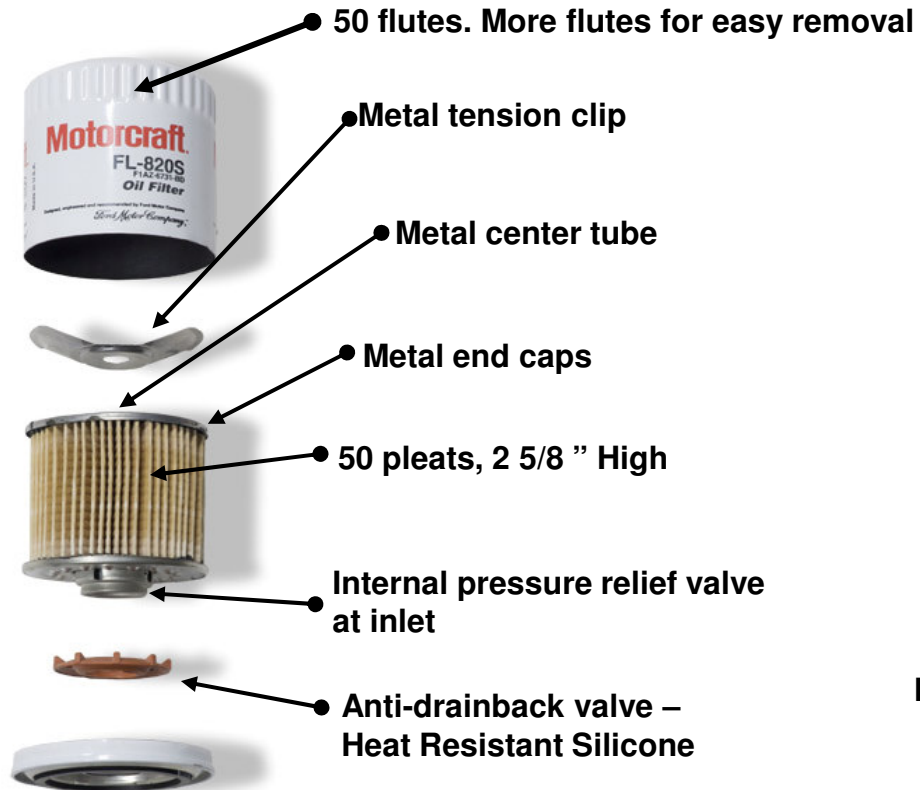

**FL-820S**

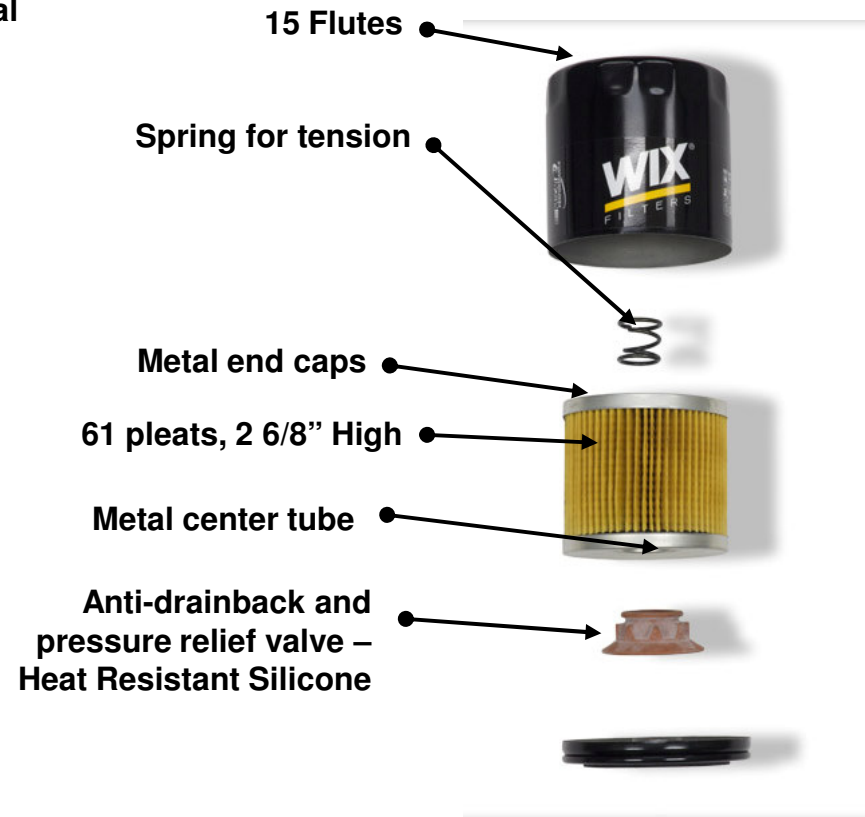

**#51372**

# Motorcraft vs. PRO-TEC

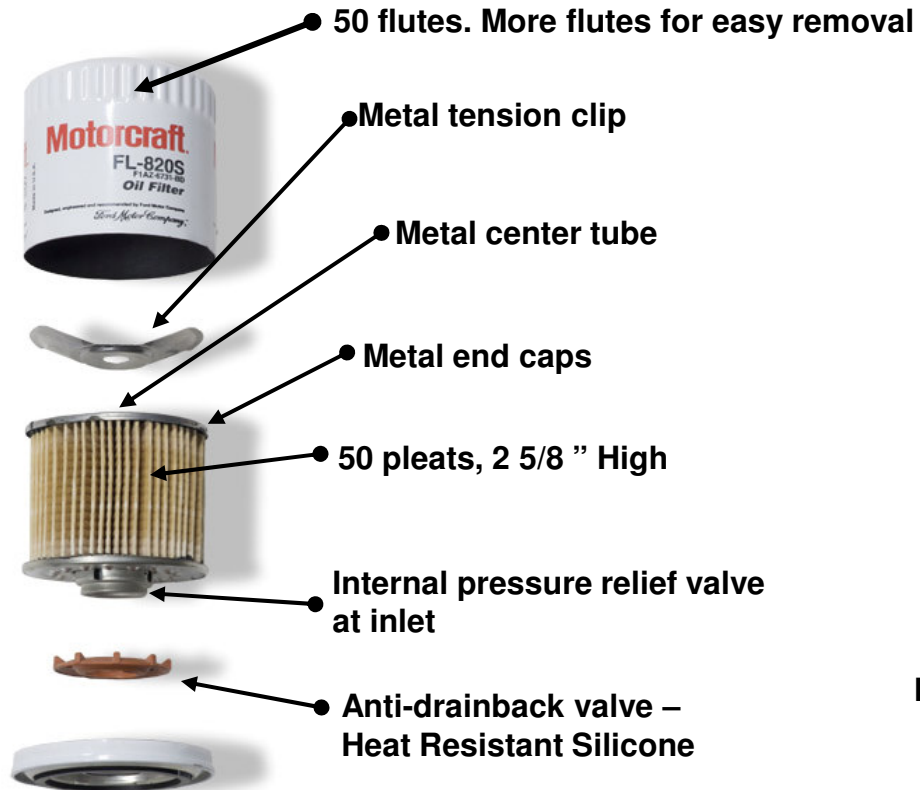

**FL-820S**

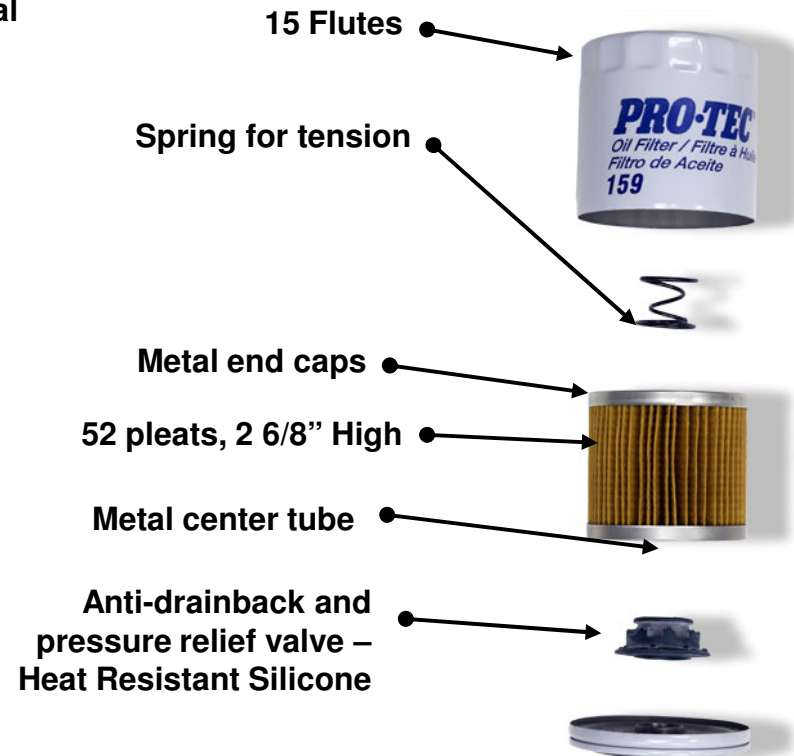

**#159**

# Motorcraft vs. NAPA Gold

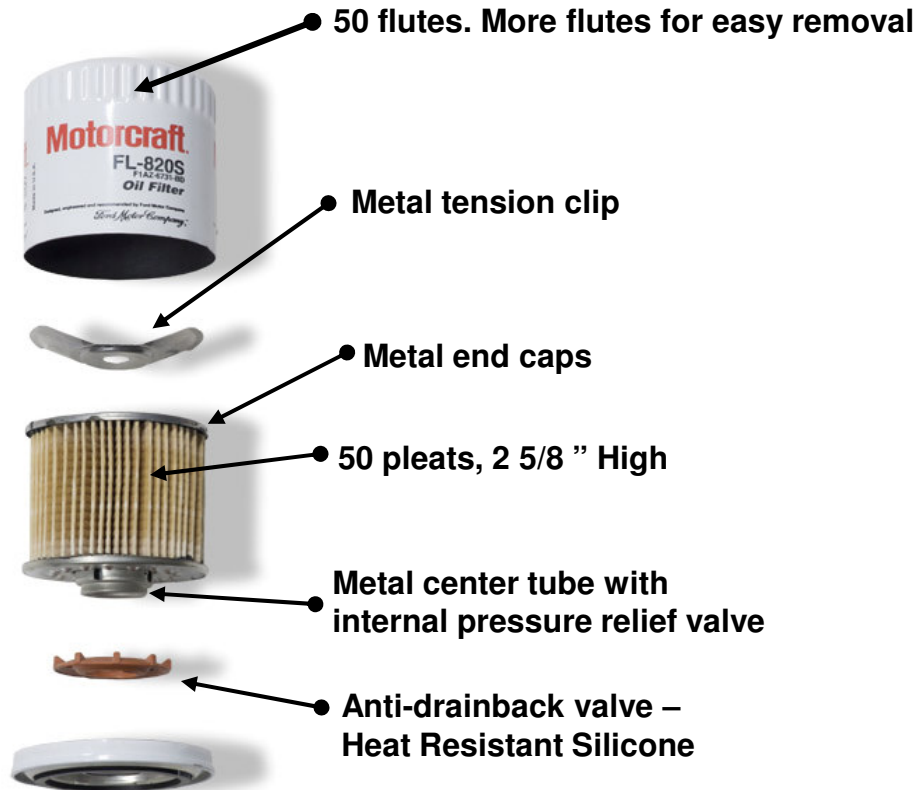

**FL-820S**

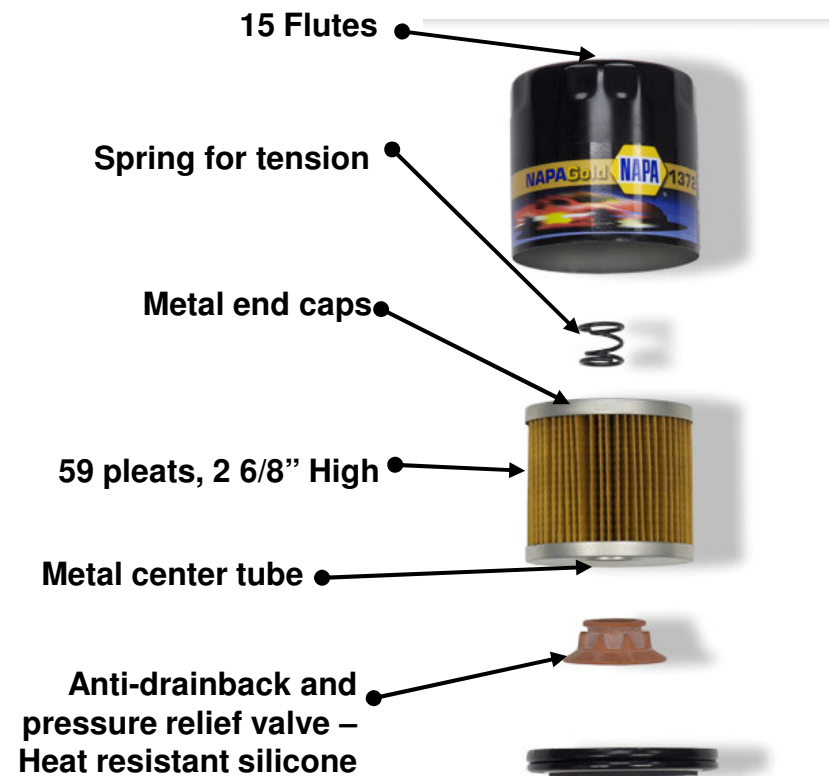

**#1372**

# Motorcraft vs. Car Quest

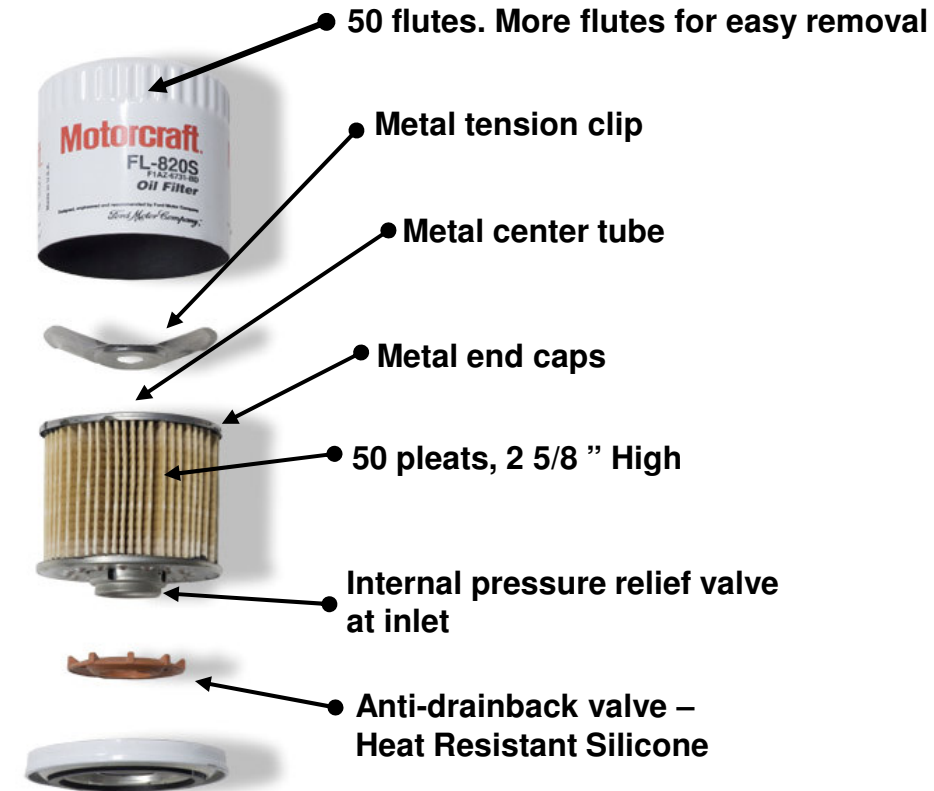

**FL-820S**

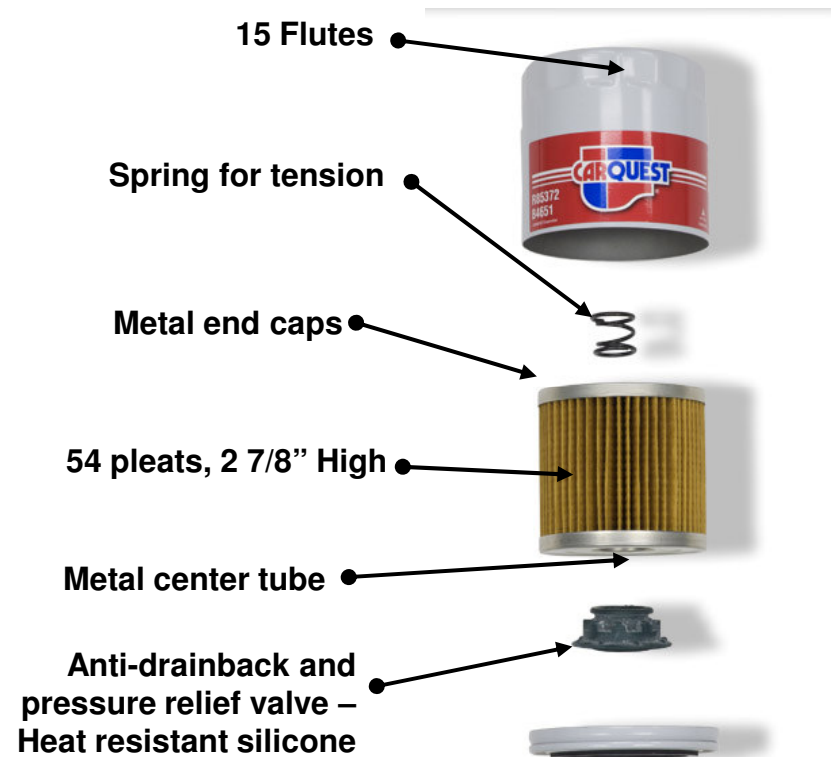

**R85272/  
B4651**

# Motorcraft vs. MotorTrend ML2

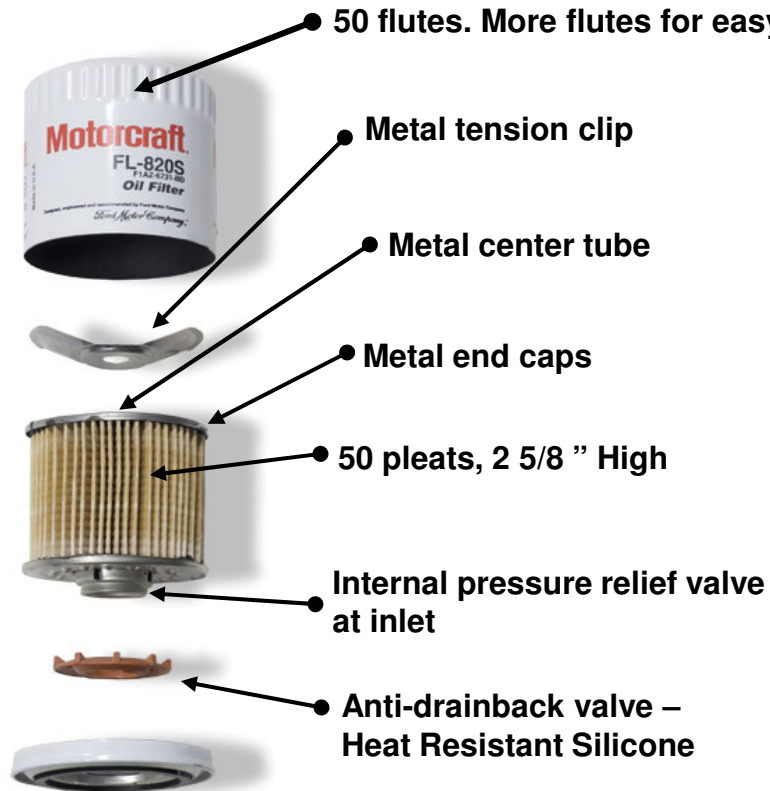

**FL-820S**



**ML-2**