

Separating Clutch Housing with HST Assembly

1. Remove the brake rods (4).
2. Remove the HST rod 1 (3).
3. Remove the power steering return hose (2), and remove the HST suction pipe (1).
4. Place the disassembling stands under the clutch housing and mid case.
5. Remove the HST to spacer case mounting screws and nuts and separate the clutch housing with HST assembly.

(When reassembling)

- Apply liquid gasket (Three Bond 1216, 1208D or equivalent) to joint face of HST and spacer case after eliminating the water, oil and stuck liquid gasket.
- Apply grease to the O-ring of HST suction pipe and take care not to damage the O-ring.

Tightening torque	HST and spacer case mounting screw and nut	103.0 to 117.7 N-m 10.5 to 12.0 kgf-m 75.9 to 86.8 ft-lbs
	HST and spacer case mounting stud bolt	39.2 to 49.0 N-m 4.0 to 5.0 kgf-m 28.9 to 36.2 ft-lbs
	Power steering return hose nut	22.6 to 27.5 N-m 2.3 to 2.8 kgf-m 16.6 to 20.2 ft-lbs

- (1) HST Suction Pipe (4) Brake Rod
(2) Power Steering Return Hose (5) HST Control Lever
(3) HST Rod 1

W1015966

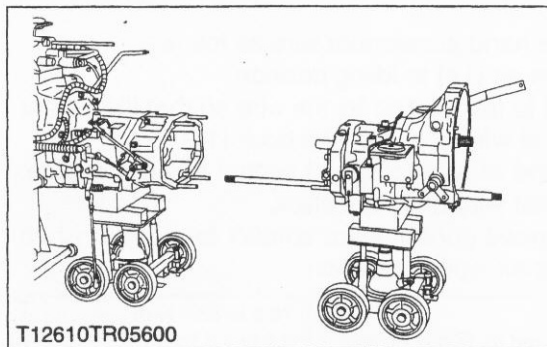
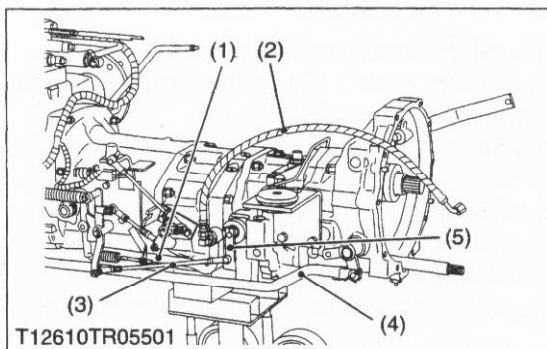

(B) Disassembling Clutch Housing

Separating Clutch Housing and HST Assembly

1. Remove the step brackets (2).
2. Remove the couplings (4).
3. Remove the HST mounting screws and nuts and separate the HST assembly (3) and clutch housing (1).

(When reassembling)

- Apply liquid gasket (Three Bond 1216, 1208D or equivalent) to joint face of the clutch housing and HST assembly after eliminating the water, oil and stuck liquid gasket.

Tightening torque	Clutch housing and HST assembly mounting nut (M14)	166.7 to 176.4 N-m 17.0 to 18.0 kgf-m 123.0 to 130.2 ft-lbs
	Clutch housing and HST assembly mounting screw and nut (M12)	103.0 to 117.7 N-m 10.5 to 12.0 kgf-m 75.9 to 86.8 ft-lbs
	Clutch housing and HST assembly mounting stud bolt (M14, M12)	39.2 to 49.0 N-m 4.0 to 5.0 kgf-m 28.9 to 36.2 ft-lbs

- (1) Clutch Housing (3) HST Assembly
(2) Step Bracket (4) Coupling

W1016182

