

LOAD & INFLATION TABLE

PSI)

Radial Ply - Symbol Marked

Conventional Size Agricultural Tractor Drive Wheel Tires

Used in Field Service and Speeds Up To 30 MPH

AT HIGHER TRANSPORT SPEEDS (ABOVE 20 MPH) AND LOWER PRESSURES (LESS THAN 12 PSI), INCREASED INFLATION PRESSURE MAY BE REQUIRED FOR VEHICLE STABILITY.

Maximum Speed - 30 MPH

TIRE LOAD		LIMITS (LBS.) AT VARIOUS COLD INFLATION PRESSURES (PSI)															
Tire Size	Inflation (psi)	6	7	8	9	10	12	14	16	18	20	22	24	26	28	30	35
	Symbol									H			H H			H H H	
13.6R24	Load Index									114			121				
	SINGLE (LBS.)	NR	NR	1650	1760	1870	2090	2270	2470	2600	2760	3000	3200				
	DUAL (LBS.)		1220	1340	1450	1550	1650	1840	2000	2170	2290	2430	2640	2820			
	TRIPLE (LBS.)	1140	1250	1350	1440	1530	1710	1860	2030	2130	2260	2460	2620				
13.6R28	Load Index									117			123			126	
	SINGLE (LBS.)	NR	NR	1760	1870	1980	2200	2400	2600	2830	3000	3200	3420	3520	3640	3740	
	DUAL (LBS.)		1300	1420	1550	1650	1740	1940	2110	2290	2490	2640	2820	3010	3100	3200	3290
	TRIPLE (LBS.)	1210	1320	1440	1530	1620	1800	1970	2130	2320	2460	2620	2800	2890	2980	3070	
14.9R24	Load Index									120			126			130	
	SINGLE (LBS.)	NR	NR	1930	2090	2200	2470	2680	2910	3080	3300	3520	3740	3860	4080	4180	
	DUAL (LBS.)		1450	1600	1700	1840	1940	2170	2360	2560	2710	2900	3100	3290	3400	3590	3680
	TRIPLE (LBS.)	1350	1490	1580	1710	1800	2030	2200	2390	2530	2710	2890	3070	3170	3350	3430	
14.9R26	Load Index									121			127			132	
	SINGLE (LBS.)	NR	NR	2040	2150	2270	2540	2760	3000	3200	3420	3640	3860	3960	4180	4400	
	DUAL (LBS.)		1500	1650	1800	1890	2000	2240	2430	2640	2820	3010	3200	3400	3480	3680	3870
	TRIPLE (LBS.)	1400	1530	1670	1760	1860	2080	2260	2460	2620	2800	2980	3170	3250	3430	3610	
14.9R28	Load Index									122			128			133	
	SINGLE (LBS.)	NR	NR	2090	2200	2340	2600	2910	3080	3300	3520	3740	3960	4180	4300	4540	
	DUAL (LBS.)		1550	1700	1840	1940	2060	2290	2560	2710	2900	3100	3290	3480	3680	3780	4000
	TRIPLE (LBS.)	1440	1580	1710	1800	1920	2130	2390	2530	2710	2890	3070	3250	3430	3530	3720	
14.9R30	Load Index									123			129			134	
	SINGLE (LBS.)	NR	NR	2150	2270	2470	2680	3000	3200	3420	3640	3860	4080	4300	4400	4680	
	DUAL (LBS.)		1600	1740	1890	2000	2170	2360	2640	2820	3010	3200	3400	3590	3780	3870	4120
	TRIPLE (LBS.)	1490	1620	1760	1860	2030	2200	2460	2620	2800	2980	3170	3350	3530	3610	3840	
14.9R34	Load Index									125			131			136	
	SINGLE (LBS.)	NR	NR	2270	2470	2600	2910	3200	3420	3640	3860	4080	4300	4540	4680	4940	
	DUAL (LBS.)		1700	1840	2000	2170	2290	2560	2820	3010	3200	3400	3590	3780	4000	4120	4350
	TRIPLE (LBS.)	1580	1710	1860	2030	2130	2390	2620	2800	2980	3170	3350	3530	3720	3840	4050	
14.9R46	Load Index									131			137			142	
	SINGLE (LBS.)	NR	NR	2680	2830	3080	3420	3740	3960	4300	4540	4800	5080	5360	5520	5840	
	DUAL (LBS.)		2000	2170	2360	2490	2710	3010	3290	3480	3780	4000	4220	4470	4720	4860	5140
	TRIPLE (LBS.)	1860	2030	2200	2320	2530	2800	3070	3250	3530	3720	3940	4170	4400	4530	4790	
15.5R38	Load Index									125							
	SINGLE (LBS.)	NR	NR	2270	2470	2600	2910	3200	3420	3640							
	DUAL (LBS.)		1700	1840	2000	2170	2290	2560	2820	3010	3200						
	TRIPLE (LBS.)	1580	1710	1860	2030	2130	2390	2620	2800	2980							
16.9R24	Load Index									126			134				
	SINGLE (LBS.)	NR	NR	2340	2540	2680	3000	3300	3520	3740	4080	4300	4680				
	DUAL (LBS.)		1740	1940	2060	2240	2360	2640	2900	3100	3290	3590	3780	4120			
	TRIPLE (LBS.)	1620	1800	1920	2080	2200	2460	2710	2890	3070	3350	3530	3840				
16.9R26	Load Index									128			135				
	SINGLE (LBS.)	NR	NR	2470	2600	2760	3080	3420	3640	3960	4180	4400	4800				

NOTE: NR Not Recommended.

LOAD & INFLATION TABLE

(Pa)

Radial Ply - Symbol Marked

Conventional Size Agricultural Tractor Drive Wheel Tires

Used in Field Service and Speeds Up To 50 MPH

AT HIGHER TRANSPORT SPEEDS (ABOVE 30 KPH) AND LOWER PRESSURES (LESS THAN 0.8 BAR), INCREASED INFLATION PRESSURE MAY BE REQUIRED FOR VEHICLE STABILITY.

Maximum Speed - 50 KPH (30 MPH)

Tire Size	TIRE LOAD LIMITS (KG) AT VARIOUS COLD INFLATION PRESSURES (kPa)																
	Inflation (kPa)	40	50	55	60	70	80	100	110	120	140	150	160	180	190	210	240
	Inflation (bar)	0.4	0.5	0.55	0.6	0.7	0.8	1.0	1.1	1.2	1.4	1.5	1.6	1.8	1.9	2.1	2.4
	Symbol									H			HH			HHH	
13.6R24	Load Index									114			121				
	SINGLE (KG)		NR	NR	750	800	850	950	1030	1120	1180	1250	1360	1450			
	DUAL (KG)	555	605	660	705	750	835	905	985	1040	1100	1195	1275				
	TRIPLE (KG)		515	565	615	655	695	780	845	920	970	1025	1115	1190			
13.6R28	Load Index									117			123			126	
	SINGLE (KG)		NR	NR	800	850	900	1000	1090	1180	1285	1360	1450	1550	1600	1650	1700
	DUAL (KG)	590	640	705	750	790	880	960	1040	1130	1195	1275	1365	1410	1450	1495	
	TRIPLE (KG)		550	600	655	695	740	820	895	970	1055	1115	1190	1270	1310	1355	1395
14.9R24	Load Index									120			126			130	
	SINGLE (KG)		NR	NR	875	950	1000	1120	1215	1320	1400	1500	1600	1700	1750	1850	1900
	DUAL (KG)	660	725	770	835	880	985	1070	1160	1230	1320	1410	1495	1540	1630	1670	
	TRIPLE (KG)		615	675	720	780	820	920	995	1080	1150	1230	1310	1395	1435	1515	1560
14.9R26	Load Index									121			127			132	
	SINGLE (KG)		NR	NR	925	975	1030	1150	1250	1360	1450	1550	1650	1750	1800	1900	2000
	DUAL (KG)	680	750	815	860	905	1010	1100	1195	1275	1365	1450	1540	1585	1670	1760	
	TRIPLE (KG)		635	695	760	800	845	945	1025	1115	1190	1270	1355	1435	1475	1560	1640
14.9R28	Load Index									122			128			133	
	SINGLE (KG)		NR	NR	950	1000	1060	1180	1320	1400	1500	1600	1700	1800	1900	1950	2060
	DUAL (KG)	705	770	835	880	935	1040	1160	1230	1320	1410	1495	1585	1670	1715	1815	
	TRIPLE (KG)		655	720	780	820	870	970	1080	1150	1230	1310	1395	1475	1560	1600	1690
14.9R30	Load Index									123			129			134	
	SINGLE (KG)		NR	NR	975	1030	1120	1215	1360	1450	1550	1650	1750	1850	1950	2000	2120
	DUAL (KG)	725	790	860	905	985	1070	1195	1275	1365	1450	1540	1630	1715	1760	1865	
	TRIPLE (KG)		675	740	800	845	920	995	1115	1190	1270	1355	1435	1515	1600	1640	1740
14.9R34	Load Index									125			131			136	
	SINGLE (KG)		NR	NR	1030	1120	1180	1320	1450	1550	1650	1750	1850	1950	2060	2120	2240
	DUAL (KG)	770	835	905	985	1040	1160	1275	1365	1450	1540	1630	1715	1815	1865	1970	
	TRIPLE (KG)		720	780	845	920	970	1080	1190	1270	1355	1435	1515	1600	1690	1740	1835
14.9R46	Load Index									131			137			142	
	SINGLE (KG)		NR	NR	1215	1285	1400	1550	1700	1800	1950	2060	2180	2300	2430	2500	2650
	DUAL (KG)	905	985	1070	1130	1230	1365	1495	1585	1715	1815	1920	2025	2140	2200	2330	
	TRIPLE (KG)		845	920	995	1055	1150	1270	1395	1475	1600	1690	1790	1885	1995	2050	2175
15.5R38	Load Index									125							
	SINGLE (KG)		NR	NR	1030	1120	1180	1320	1450	1550	1650						
	DUAL (KG)	770	835	905	985	1040	1160	1275	1365	1450							
	TRIPLE (KG)		720	780	845	920	970	1080	1190	1270	1355						
16.9R24	Load Index									126			134				
	SINGLE (KG)		NR	NR	1060	1150	1215	1360	1500	1600	1700	1850	1950	2120			
	DUAL (KG)	790	880	935	1010	1070	1195	1320	1410	1495	1630	1715	1865				
	TRIPLE (KG)		740	820	870	945	995	1115	1230	1310	1395	1515	1600	1740			
16.9R26	Load Index									128			135				
	SINGLE (KG)		NR	NR	1120	1180	1250	1400	1550	1650	1800	1900	2000	2180			
	DUAL (KG)	815	905	985	1040	1100	1230	1365	1450	1585	1670	1760	1920				
	TRIPLE (KG)		760	845	920	970	1025	1150	1270	1355	1475	1560	1640	1790			

NOTE: NR Not Recommended.

LOAD & INFLATION TABLE



Radial Ply - Symbol Marked

Conventional Size Agricultural Tractor Drive Wheel Tires

Used in Field Service and Speeds Up To 30 MPH

AT HIGHER TRANSPORT SPEEDS (ABOVE 20 MPH) AND LOWER PRESSURES (LESS THAN 12 PSI), INCREASED INFLATION PRESSURE MAY BE REQUIRED FOR VEHICLE STABILITY.

Maximum Speed - 30 MPH

Tire Size	TIRE LOAD LIMITS (LBS.) AT VARIOUS COLD INFLATION PRESSURES (PSI)																
	Inflation (psi)	6	7	8	9	10	12	14	16	18	20	22	24	26	28	30	35
	Symbol									H			H H			H H H	
16.9R28	Load Index									129			136				
	SINGLE (LBS.)	NR	NR	2540	2680	2910	3200	3520	3740	4080	4300	4540	4940				
	DUAL (LBS.)		1890	2060	2240	2360	2560	2820	3100	3290	3590	3780	4000	4350			
	TRIPLE (LBS.)	1760	1920	2080	2200	2390	2620	2890	3070	3350	3530	3720	4050				
16.9R30	Load Index									130			137			141	144
	SINGLE (LBS.)	NR	NR	2600	2760	3000	3300	3640	3860	4180	4400	4680	5080	5200	5360	5680	6150
	DUAL (LBS.)		1940	2110	2290	2430	2640	2900	3200	3400	3680	3870	4120	4470	4580	4720	5000
	TRIPLE (LBS.)	1800	1970	2130	2260	2460	2710	2980	3170	3430	3610	3840	4170	4260	4400	4660	5040
16.9R38	Load Index									134			141				
	SINGLE (LBS.)	NR	NR	2910	3080	3300	3740	4080	4400	4680	4940	5360	5680				
	DUAL (LBS.)		2170	2360	2560	2710	2900	3290	3590	3870	4120	4350	4720	5000			
	TRIPLE (LBS.)	2030	2200	2390	2530	2710	3070	3350	3610	3840	4050	4400	4660				
18.4R26	Load Index									134			140				
	SINGLE (LBS.)	NR	NR	2910	3080	3300	3740	4080	4400	4680	4940	5360	5520				
	DUAL (LBS.)		2170	2360	2560	2710	2900	3290	3590	3870	4120	4350	4720	4860			
	TRIPLE (LBS.)	2030	2200	2390	2530	2710	3070	3350	3610	3840	4050	4400	4530				
18.4R30	Load Index									136			142				
	SINGLE (LBS.)	NR	NR	3080	3300	3520	3960	4300	4680	4940	5360	5680	5840				
	DUAL (LBS.)		2290	2560	2710	2900	3100	3480	3780	4120	4350	4720	5000	5140			
	TRIPLE (LBS.)	2130	2390	2530	2710	2890	3250	3530	3840	4050	4400	4660	4790				
18.4R34	Load Index									139			144				
	SINGLE (LBS.)	NR	NR	3300	3520	3740	4180	4540	4940	5360	5680	6000	6150				
	DUAL (LBS.)		2490	2710	2900	3100	3290	3680	4000	4350	4720	5000	5280	5410			
	TRIPLE (LBS.)	2320	2530	2710	2890	3070	3430	3720	4050	4400	4660	4920	5040				
18.4R38	Load Index									141			146				
	SINGLE (LBS.)	NR	NR	3520	3740	3960	4400	4800	5200	5680	6000	6400	6600				
	DUAL (LBS.)		2640	2820	3100	3290	3480	3870	4220	4580	5000	5280	5630	5810			
	TRIPLE (LBS.)	2460	2620	2890	3070	3250	3610	3940	4260	4660	4920	5250	5410				
18.4R42	Load Index									143			148				
	SINGLE (LBS.)	NR	NR	3740	3960	4180	4680	5080	5520	6000	6400	6600	6950				
	DUAL (LBS.)		2710	3010	3290	3480	3680	4120	4470	4860	5280	5630	5810	6120			
	TRIPLE (LBS.)	2530	2800	3070	3250	3430	3840	4170	4530	4920	5250	5410	5700				
18.4R46	Load Index									144			150			155	
	SINGLE (LBS.)	NR	NR	3860	4180	4400	4940	5360	5840	6150	6600	6950	7400	7850	8050	8550	
	DUAL (LBS.)		2900	3200	3400	3680	3870	4350	4720	5140	5410	5810	6120	6510	6910	7080	7520
	TRIPLE (LBS.)	2710	2980	3170	3430	3610	4050	4400	4790	5040	5410	5700	6070	6440	6600	7010	
20.8R34	Load Index									145							
	SINGLE (LBS.)	NR	NR	3960	4300	4540	5080	5520	6000	6400							
	DUAL (LBS.)		3010	3290	3480	3780	4000	4470	4860	5280	5630						
	TRIPLE (LBS.)	2800	3070	3250	3530	3720	4170	4530	4920	5250							
20.8R38	Load Index									147			153				
	SINGLE (LBS.)	NR	NR	4300	4540	4800	5360	5840	6400	6800	7150	7600	8050				
	DUAL (LBS.)		3200	3480	3780	4000	4220	4720	5140	5630	5980	6290	6690	7080			
	TRIPLE (LBS.)	2980	3250	3530	3720	3940	4400	4790	5250	5580	5860	6230	6600				

NOTE: NR Not Recommended.

LOAD & INFLATION TABLE

(Pa)

Radial Ply - Symbol Marked

Conventional Size Agricultural Tractor Drive Wheel Tires

Used in Field Service and Speeds Up To 50 MPH

AT HIGHER TRANSPORT SPEEDS (ABOVE 30 KPH) AND LOWER PRESSURES (LESS THAN 0.8 BAR), INCREASED INFLATION PRESSURE MAY BE REQUIRED FOR VEHICLE STABILITY.

Maximum Speed - 50 KPH (30 MPH)

TIRE LOAD		LIMITS (KG) AT VARIOUS COLD INFLATION PRESSURES (kPa)															
Tire Size	Inflation (kPa)	40	50	55	60	70	80	100	110	120	140	150	160	180	190	210	240
	Inflation (bar)	0.4	0.5	0.55	0.6	0.7	0.8	1.0	1.1	1.2	1.4	1.5	1.6	1.8	1.9	2.1	2.4
	Symbol									H			HH			HHH	
16.9R28	Load Index									129			136				
	SINGLE (KG)		NR	NR	1150	1215	1320	1450	1600	1700	1850	1950	2060	2240			
	DUAL (KG)	860	935	1010	1070	1160	1275	1410	1495	1630	1715	1815	1970				
	TRIPLE (KG)		800	870	945	995	1080	1190	1310	1395	1515	1600	1690	1835			
16.9R30	Load Index									130			137			141	144
	SINGLE (KG)		NR	NR	1180	1250	1360	1500	1650	1750	1900	2000	2120	2300	2360	2430	2575
	DUAL (KG)	880	960	1040	1100	1195	1320	1450	1540	1670	1760	1865	2025	2075	2140	2265	2465
	TRIPLE (KG)		820	895	970	1025	1115	1230	1355	1435	1560	1640	1740	1885	1935	1995	2110
16.9R38	Load Index									134			141				
	SINGLE (KG)		NR	NR	1320	1400	1500	1700	1850	2000	2120	2240	2430	2575			
	DUAL (KG)	985	1070	1160	1230	1320	1495	1630	1760	1865	1970	2140	2265				
	TRIPLE (KG)		920	995	1080	1150	1230	1395	1515	1640	1740	1835	1995	2110			
18.4R26	Load Index									134			140				
	SINGLE (KG)		NR	NR	1320	1400	1500	1700	1850	2000	2120	2240	2430	2500			
	DUAL (KG)	985	1070	1160	1230	1320	1495	1630	1760	1865	1970	2140	2200				
	TRIPLE (KG)		920	995	1080	1150	1230	1395	1515	1640	1740	1835	1995	2050			
18.4R30	Load Index									136			142				
	SINGLE (KG)		NR	NR	1400	1500	1600	1800	1950	2120	2240	2430	2575	2650			
	DUAL (KG)	1040	1160	1230	1320	1410	1585	1715	1865	1970	2140	2265	2330				
	TRIPLE (KG)		970	1080	1150	1230	1310	1475	1600	1740	1835	1995	2110	2175			
18.4R34	Load Index									139			144				
	SINGLE (KG)		NR	NR	1500	1600	1700	1900	2060	2240	2430	2575	2725	2800			
	DUAL (KG)	1130	1230	1320	1410	1495	1670	1815	1970	2140	2265	2400	2465				
	TRIPLE (KG)		1055	1150	1230	1310	1395	1560	1690	1835	1995	2110	2235	2295			
18.4R38	Load Index									141			146				
	SINGLE (KG)		NR	NR	1600	1700	1800	2000	2180	2360	2575	2725	2900	3000			
	DUAL (KG)	1195	1275	1410	1495	1585	1760	1920	2075	2265	2400	2550	2640				
	TRIPLE (KG)		1115	1190	1310	1395	1475	1640	1790	1935	2110	2235	2380	2460			
18.4R42	Load Index									143			148				
	SINGLE (KG)		NR	NR	1700	1800	1900	2120	2300	2500	2725	2900	3000	3150			
	DUAL (KG)	1230	1365	1495	1585	1670	1865	2025	2200	2400	2550	2640	2770				
	TRIPLE (KG)		1150	1270	1395	1475	1560	1740	1885	2050	2235	2380	2460	2585			
18.4R46	Load Index									144			150			155	
	SINGLE (KG)		NR	NR	1750	1900	2000	2240	2430	2650	2800	3000	3150	3350	3550	3650	3875
	DUAL (KG)	1320	1450	1540	1670	1760	1970	2140	2330	2465	2640	2770	2950	3125	3210	3410	
	TRIPLE (KG)		1230	1355	1435	1560	1640	1835	1995	2175	2295	2460	2585	2745	2910	2995	3180
20.8R34	Load Index									145							
	SINGLE (KG)		NR	NR	1800	1950	2060	2300	2500	2725	2900						
	DUAL (KG)	1365	1495	1585	1715	1815	2025	2200	2400	2550							
	TRIPLE (KG)		1270	1395	1475	1600	1690	1885	2050	2235	2380						
20.8R38	Load Index									147			153				
	SINGLE (KG)		NR	NR	1950	2060	2180	2430	2650	2900	3075	3250	3450	3650			
	DUAL (KG)	1450	1585	1715	1815	1920	2140	2330	2550	2705	2860	3035	3210				

NOTE: NR Not Recommended.

LOAD & INFLATION TABLE



Radial Ply - Symbol Marked

Conventional Size Agricultural Tractor Drive Wheel Tires

Used in Field Service and Speeds Up To 30 MPH

AT HIGHER TRANSPORT SPEEDS (ABOVE 20 MPH) AND LOWER PRESSURES (LESS THAN 12 PSI), INCREASED INFLATION PRESSURE MAY BE REQUIRED FOR VEHICLE STABILITY.

Maximum Speed - 30 MPH

Tire Size	TIRE LOAD LIMITS (LBS.) AT VARIOUS COLD INFLATION PRESSURES (PSI)																
	Inflation (psi)	6	7	8	9	10	12	14	16	18	20	22	24	26	28	30	35
	Symbol									H			H H			H H H	
20.8R42	Load Index									149			155				
	SINGLE (LBS.)	NR	NR	4540	4800	5080	5680	6150	6800	7150	7600	8050	8550				
	DUAL (LBS.)		3290	3680	4000	4220	4470	5000	5410	5980	6290	6690	7080	7520			
	TRIPLE (LBS.)	3070	3430	3720	3940	4170	4660	5040	5580	5860	6230	6600	7010				
23.1R26	Load Index									147			153				
	SINGLE (LBS.)	NR	NR	4180	4540	4800	5360	5840	6400	6800	7150	7600	8050				
	DUAL (LBS.)		3100	3400	3680	4000	4220	4720	5140	5630	5980	6290	6690	7080			
	TRIPLE (LBS.)	2890	3170	3430	3720	3940	4400	4790	5250	5580	5860	6230	6600				
24.5R32	Load Index									154			159				
	SINGLE (LBS.)	NR	NR	5080	5520	5840	6400	7150	7600	8250	8800	9100	9650				
	DUAL (LBS.)	3780	4120	4470	4860	5140	5630	6290	6690	7260	7740	8010	8490				
	TRIPLE (LBS.)	3530	3840	4170	4530	4790	5250	5860	6230	6770	7220	7460	7910				
28LR26	Load Index									152			157			162	165
	SINGLE (LBS.)	NR	NR	4800	5200	5520	6150	6800	7400	7850	8250	8800	9100	9650	10200	10500	11400
	DUAL (LBS.)	3590	4000	4220	4580	4860	5410	5980	6510	6910	7260	7740	8010	8490	8980	9240	10030
	TRIPLE (LBS.)	3350	3720	3940	4260	4530	5040	5580	6070	6440	6770	7220	7460	7910	8360	8610	9350
30.5LR32	Load Index									159							
	SINGLE (LBS.)	NR	NR	6150	6600	6950	7600	8550	9100	9650							
	DUAL (LBS.)	4470	5000	5410	5810	6120	6690	7520	8010	8490							
	TRIPLE (LBS.)	4170	4660	5040	5410	5700	6230	7010	7460	7910							

NOTES 1. For shipping purposes, tire inflation pressures may be increased to 30 psi (consult tire manufacturer for minimum tire shipping pressure). Inflation pressure must be reduced to operating inflation before the tractor is removed from the carrier.

2. For above tires used in cyclic loading service (excluding hillside combines) without sustained high torque with speeds up to 5 MPH, above loads may be increased 70% (with 6 psi increase in inflation pressure). This load increase is also applicable to tires used on vehicles with mechanism capable of maintaining tires and wheels in a vertical position on slopes up to 11 (20% grade). Due to higher pressure specified for these tires, the rim and wheel manufacturers must be consulted.

3. For transport service and operations which do not require sustained high torque, the following load limits at various speeds apply with no change in inflation pressure:

MAXIMUM SPEED	% CHANGE IN LOADS IN ABOVE TABLE
10 MPH	+34% (except Hillside Combines)
15 MPH	+11% (except Hillside Combines)
20 MPH	+7%
25 MPH	NONE
30 MPH	NONE

4. NR Not Recommended.

LOAD & INFLATION TABLE

(Pa)

Radial Ply - Symbol Marked

Conventional Size Agricultural Tractor Drive Wheel Tires

Used in Field Service and Speeds Up To 50 MPH

AT HIGHER TRANSPORT SPEEDS (ABOVE 30 KPH) AND LOWER PRESSURES (LESS THAN 0.8 BAR), INCREASED INFLATION PRESSURE MAY BE REQUIRED FOR VEHICLE STABILITY.

Maximum Speed - 50 KPH (30 MPH)

Tire Size	TIRE LOAD LIMITS (KG) AT VARIOUS COLD INFLATION PRESSURES (kPa)																
	Inflation (kPa)	40	50	55	60	70	80	100	110	120	140	150	160	180	190	210	240
	Inflation (bar)	0.4	0.5	0.55	0.6	0.7	0.8	1.0	1.1	1.2	1.4	1.5	1.6	1.8	1.9	2.1	2.4
	Symbol									H			HH			HHH	
20.8R42	Load Index									149			155				
	SINGLE (KG)		NR	NR	2060	2180	2300	2575	2800	3075	3250	3450	3650	3875			
	DUAL (KG)	1495	1670	1815	1920	2025	2265	2465	2705	2860	3035	3210	3410				
	TRIPLE (KG)		1395	1560	1690	1790	1885	2110	2295	2520	2665	2830	2995	3180			
23.1R26	Load Index									147			153				
	SINGLE (KG)		NR	NR	1900	2060	2180	2430	2650	2900	3075	3250	3450	3650			
	DUAL (KG)	1410	1540	1670	1815	1920	2140	2330	2550	2705	2860	3035	3210				
	TRIPLE (KG)		1310	1435	1560	1690	1790	1995	2175	2380	2520	2665	2830	2995			
24.5R32	Load Index									154			159				
	SINGLE (KG)		NR	NR	2300	2500	2650	2900	3250	3450	3750	4000	4125	4375			
	DUAL (KG)	1715	1865	2025	2200	2330	2550	2860	3035	3300	3520	3630	3850				
	TRIPLE (KG)		1600	1740	1885	2050	2175	2380	2665	2830	3075	3280	3385	3590			
28LR26	Load Index									152			157			162	165
	SINGLE (KG)		NR	NR	2180	2360	2500	2800	3075	3350	3550	3750	4000	4125	4375	4625	4750
	DUAL (KG)	1630	1815	1920	2075	2200	2465	2705	2950	3125	3300	3520	3630	3850	4070	4180	4530
	TRIPLE (KG)		1515	1690	1790	1935	2050	2295	2520	2745	2910	3075	3280	3385	3590	3795	3895
30.5LR32	Load Index									159							
	SINGLE (KG)		NR	NR	2800	3000	3150	3450	3875	4125	4375						
	DUAL (KG)	2025	2265	2465	2640	2770	3035	3410	3630	3850							

- NOTES
- For shipping purposes, tire inflation pressures may be increased to 30 psi (consult tire manufacturer for minimum tire shipping pressure). Inflation pressure must be reduced to operating inflation before the tractor is removed from the carrier.
 - For above tires used in cyclic loading service (excluding hillside combines) without sustained high torque with speeds up to 5 MPH, above loads may be increased 70% (with 6 psi increase in inflation pressure). This load increase is also applicable to tires used on vehicles with mechanism capable of maintaining tires and wheels in a vertical position on slopes up to 1:1 (20% grade). Due to higher pressure specified for these tires, the rim and wheel manufacturers must be consulted.
 - For transport service and operations which do not require sustained high torque, the following load limits at various speeds apply with no change in inflation pressure:

MAXIMUM SPEED	% CHANGE IN LOADS IN ABOVE TABLE
10 MPH	+34% (except Hillside Combines)
15 MPH	+11% (except Hillside Combines)
20 MPH	+7%
25 MPH	NONE
30 MPH	NONE

4 NR Not Recommended.

LOAD & INFLATION TABLE

PSI)

Radial Ply Metric Size Agricultural Tractor Drive Wheel Tires
Used in Field Service and Speeds Up To 30 KPH

AT HIGHER TRANSPORT SPEEDS (ABOVE 20 MPH) AND LOWER PRESSURES (LESS THAN 12 PSI),
INCREASED INFLATION PRESSURE MAY BE REQUIRED FOR VEHICLE STABILITY.

Maximum Speed - 30 MPH

Tire Size	Inflation (psi)	TIRE LOAD LIMITS (LBS.) AT VARIOUS COLD INFLATION PRESSURES (PSI)															
		6	7	9	10	12	13	15	17	20	23	26	29	35	41	46	52
250/95R34	Load Index								111		119						
	Single (LBS.)		NR	NR	1610	1760	1870	2040	2150	2400	2680	3000					
	Dual (LBS.)	1200	1300	1420	1550	1650	1800	1890	2110	2360	2640						
	Triple (LBS.)		1120	1210	1320	1440	1530	1670	1760	1970	2200	2460					
250/90R38	Load Index								112		119		122	124	127	130	132
	Single (LBS.)		NR	NR	1650	1760	1930	2040	2200	2470	2760	3000	3200	3300	3520	3860	4180
	Dual (LBS.)	1200	1340	1450	1550	1700	1800	1940	2170	2430	2640	2820	2900	3100	3400	3680	3870
	Triple (LBS.)		1120	1250	1350	1440	1580	1670	1800	2030	2260	2460	2620	2710	2890	3170	3430
250/95R50	Load Index								119		125		128	131	134	137	
	Single (LBS.)		NR	NR	1980	2150	2340	2470	2680	3000	3300	3640	3860	3960	4300	4680	5080
	Dual (LBS.)	1450	1600	1740	1890	2060	2170	2360	2640	2900	3200	3400	3480	3780	4120	4470	
	Triple (LBS.)		1350	1490	1620	1760	1920	2030	2200	2460	2710	2980	3170	3250	3530	3840	4170
250/95R54	Load Index								120		127		130	132	136	138	141
	Single (LBS.)		NR	NR	2090	2270	2400	2600	2760	3080	3420	3860	3960	4180	4400	4940	5200
	Dual (LBS.)	1500	1700	1840	2000	2110	2290	2430	2710	3010	3400	3480	3680	3870	4350	4580	5000
	Triple (LBS.)		1400	1580	1710	1860	1970	2130	2260	2530	2800	3170	3250	3430	3610	4050	4260
290/95R34	Load Index								119		125		129	131			
	Single (LBS.)		NR	NR	2040	2200	2340	2540	2680	3000	3300	3640	3860	4080	4300		
	Dual (LBS.)	1450	1600	1800	1940	2060	2240	2360	2640	2900	3200	3400	3590	3780			
	Triple (LBS.)		1350	1490	1670	1800	1920	2080	2200	2460	2710	2980	3170	3350	3530		
290/90R38	Load Index								120		126		129	132	135	138	
	Single (LBS.)		NR	NR	2040	2200	2400	2540	2680	3080	3420	3740	3960	4080	4400	4800	5200
	Dual (LBS.)	1500	1650	1800	1940	2110	2240	2360	2710	3010	3290	3480	3590	3870	4220	4580	
	Triple (LBS.)		1400	1530	1670	1800	1970	2080	2200	2530	2800	3070	3250	3350	3610	3940	4260
290/90R42	Load Index								121		128		131	133	137	140	
	Single (LBS.)		NR	NR	2150	2340	2540	2680	2830	3200	3520	3960	4180	4300	4540	5080	5520
	Dual (LBS.)	1550	1740	1890	2060	2240	2360	2490	2820	3100	3480	3680	3780	4000	4470	4860	
	Triple (LBS.)		1440	1620	1760	1920	2080	2200	2320	2620	2890	3250	3430	3530	3720	4170	4530
320/75R24	Load Index								111		118						
	Single (LBS.)		NR	NR	1610	1760	1870	2040	2150	2400	2680	2910					
	Dual (LBS.)	1200	1300	1420	1550	1650	1800	1890	2110	2360	2560						
	Triple (LBS.)		1120	1210	1320	1440	1530	1670	1760	1970	2200	2390					
320/85R34	Load Index								121		127		131	133			
	Single (LBS.)		NR	NR	2150	2270	2470	2680	2830	3200	3520	3860	4080	4300	4540		
	Dual (LBS.)	1550	1700	1890	2000	2170	2360	2490	2820	3100	3400	3590	3780	4000			
	Triple (LBS.)		1440	1580	1760	1860	2030	2200	2320	2620	2890	3170	3350	3530	3720		
320/85R38	Load Index								123		129		133	135	138	141	143
	Single (LBS.)		NR	NR	2270	2400	2600	2830	3000	3420	3740	4080	4300	4540	4800	5200	5680
	Dual (LBS.)	1650	1800	2000	2110	2290	2490	2640	3010	3290	3590	3780	4000	4220	4580	5000	5280
	Triple (LBS.)		1530	1670	1860	1970	2130	2320	2460	2800	3070	3350	3530	3720	3940	4260	4660

NOTE: NR Not Recommended.
320/80R42 Load Index

123 130 133 135 139 141

LOAD & INFLATION TABLE

(Pa)

Radial Ply Metric Size Agricultural Tractor Drive Wheel Tires
Used in Field Service and Speeds Up To 50 KPH

AT HIGHER TRANSPORT SPEEDS (ABOVE 30 KPH) AND LOWER PRESSURES (LESS THAN 0.8 BAR),
INCREASED INFLATION PRESSURE MAY BE REQUIRED FOR VEHICLE STABILITY.

Maximum Speed - 50 KPH (30 MPH)

Tire Size	TIRE LOAD LIMITS (KG) AT VARIOUS COLD INFLATION PRESSURES (kPa)																
	Inflation (kPa)	40	50	60	70	80	90	100	120	140	160	180	200	240	280	320	360
	Inflation (bar)	0.4	0.5	0.6	0.7	0.8	0.9	1.0	1.2	1.4	1.6	1.8	2.0	2.4	2.8	3.2	3.6
250/95R34	Load Index								111		119						
	Single (KG)	NR	NR	730	800	850	925	975	1090	1215	1360						
	Dual (KG)	540	590	640	705	750	815	860	960	1070	1195						
	Triple (KG)	505	550	600	655	695	760	800	895	995	1115						
250/90R38	Load Index								112		119		122	124	127	130	132
	Single (KG)	NR	NR	750	800	875	925	1000	1120	1250	1360	1450	1500	1600	1750	1900	2000
	Dual (KG)	540	605	660	705	770	815	880	985	1100	1195	1275	1320	1410	1540	1670	1760
	Triple (KG)	505	565	615	655	720	760	820	920	1025	1115	1190	1230	1310	1435	1560	1640
250/95R50	Load Index								119		125		128	131	134	137	
	Single (KG)	NR	NR	900	975	1060	1120	1215	1360	1500	1650	1750	1800	1950	2120	2300	
	Dual (KG)	660	725	790	860	935	985	1070	1195	1320	1450	1540	1585	1715	1865	2025	
	Triple (KG)	615	675	740	800	870	920	995	1115	1230	1355	1435	1475	1600	1740	1885	
250/95R54	Load Index								120		127		130	132	136	138	141
	Single (KG)	NR	NR	950	1030	1090	1180	1250	1400	1550	1750	1800	1900	2000	2240	2360	2575
	Dual (KG)	680	770	835	905	960	1040	1100	1230	1365	1540	1585	1670	1760	1970	2075	2265
	Triple (KG)	635	720	780	845	895	970	1025	1150	1270	1435	1475	1560	1640	1835	1935	2110
290/95R34	Load Index								119		125		129	131			
	Single (KG)	NR	NR	925	1000	1060	1150	1215	1360	1500	1650	1750	1850	1950			
	Dual (KG)	660	725	815	880	935	1010	1070	1195	1320	1450	1540	1630	1715			
	Triple (KG)	615	675	760	820	870	945	995	1115	1230	1355	1435	1515	1600			
290/90R38	Load Index								120		126		129	132	135	138	
	Single (KG)	NR	NR	925	1000	1090	1150	1215	1400	1550	1700	1800	1850	2000	2180	2360	
	Dual (KG)	680	750	815	880	960	1010	1070	1230	1365	1495	1585	1630	1760	1920	2075	
	Triple (KG)	635	695	760	820	895	945	995	1150	1270	1395	1475	1515	1640	1790	1935	
290/90R42	Load Index								121		128		131	133	137	140	
	Single (KG)	NR	NR	975	1060	1150	1215	1285	1450	1600	1800	1900	1950	2060	2300	2500	
	Dual (KG)	705	790	860	935	1010	1070	1130	1275	1410	1585	1670	1715	1815	2025	2200	
	Triple (KG)	655	740	800	870	945	995	1055	1190	1310	1475	1560	1600	1690	1885	2050	
320/75R24	Load Index								111		118						
	Single (KG)	NR	NR	730	800	850	925	975	1090	1215	1320						
	Dual (KG)	540	590	640	705	750	815	860	960	1070	1160						
	Triple (KG)	505	550	600	655	695	760	800	895	995	1080						
320/85R34	Load Index								121		127		131	133			
	Single (KG)	NR	NR	975	1030	1120	1215	1285	1450	1600	1750	1850	1950	2060			
	Dual (KG)	705	770	860	905	985	1070	1130	1275	1410	1540	1630	1715	1815			
	Triple (KG)	655	720	800	845	920	995	1055	1190	1310	1435	1515	1600	1690			
320/85R38	Load Index								123		129		133	135	138	141	143
	Single (KG)	NR	NR	1030	1090	1180	1285	1360	1550	1700	1850	1950	2060	2180	2360	2575	2725
	Dual (KG)	750	815	905	960	1040	1130	1195	1365	1495	1630	1715	1815	1920	2075	2265	2400
	Triple (KG)	695	760	845	895	970	1055	1115	1270	1395	1515	1600	1690	1790	1935	2110	2235
320/80R42	Load Index								123		130		133	135	139	141	
	Single (KG)	NR	NR	1030	1120	1180	1285	1360	1550	1700	1900	1950	2060	2180	2430	2575	
	Dual (KG)	750	835	905	985	1040	1130	1195	1365	1495	1670	1715	1815	1920	2140	2265	
	Triple (KG)	695	780	845	920	970	1055	1115	1270	1395	1560	1600	1690	1790	1995	2110	

NOTE: NR Not Recommended.

LOAD & INFLATION TABLE

PSI)

Radial Ply Metric Size Agricultural Tractor Drive Wheel Tires
Used in Field Service and Speeds Up To 30 KPH

AT HIGHER TRANSPORT SPEEDS (ABOVE 20 MPH) AND LOWER PRESSURES (LESS THAN 12 PSI),
INCREASED INFLATION PRESSURE MAY BE REQUIRED FOR VEHICLE STABILITY.

Maximum Speed - 30 MPH

Tire Size	Inflation (psi)	TIRE LOAD LIMITS (LBS.) AT VARIOUS COLD INFLATION PRESSURES (PSI)															
		6	7	9	10	12	13	15	17	20	23	26	29	35	41	46	52
320/90R42	Load Index								126		133		136	139			
	Single (LBS.)		NR	NR	2470	2680	2910	3080	3300	3740	4180	4540	4800	4940	5360		
	Dual (LBS.)	1840	2000	2170	2360	2560	2710	2900	3290	3680	4000	4220	4350	4720			
	Triple (LBS.)		1710	1860	2030	2200	2390	2530	2710	3070	3430	3720	3940	4050	4400		
320/90R46	Load Index								127		135		138	140	144	146	148
	Single (LBS.)		NR	NR	2600	2830	3000	3300	3420	3860	4300	4800	5080	5200	5520	6150	6600
	Dual (LBS.)	1890	2110	2290	2490	2640	2900	3010	3400	3780	4220	4470	4580	4860	5410	5810	6120
	Triple (LBS.)		1760	1970	2130	2320	2460	2710	2800	3170	3530	3940	4170	4260	4530	5040	5410
320/90R50	Load Index								129		136		140	142	145	148	
	Single (LBS.)		NR	NR	2760	2910	3200	3420	3640	4080	4540	4940	5200	5520	5840	6400	6950
	Dual (LBS.)	2000	2170	2430	2560	2820	3010	3200	3590	4000	4350	4580	4860	5140	5630	6120	
	Triple (LBS.)		1860	2030	2260	2390	2620	2800	2980	3350	3720	4050	4260	4530	4790	5250	5700
320/90R54	Load Index								131		138		141	143	146	149	
	Single (LBS.)		NR	NR	2830	3080	3300	3520	3740	4300	4680	5200	5520	5680	6000	6600	7150
	Dual (LBS.)	2060	2290	2490	2710	2900	3100	3290	3780	4120	4580	4860	5000	5280	5810	6290	
	Triple (LBS.)		1920	2130	2320	2530	2710	2890	3070	3530	3840	4260	4530	4660	4920	5410	5860
340/85R46	Load Index								129		136		140				
	Single (LBS.)		NR	NR	2760	2910	3200	3420	3640	4080	4540	4940	5200	5520			
	Dual (LBS.)	2000	2170	2430	2560	2820	3010	3200	3590	4000	4350	4580	4860				
	Triple (LBS.)		1860	2030	2260	2390	2620	2800	2980	3350	3720	4050	4260	4530			
380/85R28	Load Index								126		133						
	Single (LBS.)		NR	NR	2540	2680	2910	3080	3300	3740	4180	4540					
	Dual (LBS.)	1840	2000	2240	2360	2560	2710	2900	3290	3680	4000						
	Triple (LBS.)		1710	1860	2080	2200	2390	2530	2710	3070	3430	3720					
380/85R30	Load Index								127		135						
	Single (LBS.)		NR	NR	2600	2830	3000	3200	3420	3860	4300	4800					
	Dual (LBS.)	1890	2110	2290	2490	2640	2820	3010	3400	3780	4220						
	Triple (LBS.)		1760	1970	2130	2320	2460	2620	2800	3170	3530	3940					
380/85R34	Load Index								129		137		140	142			
	Single (LBS.)		NR	NR	2760	3000	3200	3420	3640	4080	4540	5080	5360	5520	5840		
	Dual (LBS.)	2000	2240	2430	2640	2820	3010	3200	3590	4000	4470	4720	4860	5140			
	Triple (LBS.)		1860	2080	2260	2460	2620	2800	2980	3350	3720	4170	4400	4530	4790		
380/80R38	Load Index								130		137		140	142			
	Single (LBS.)		NR	NR	2760	3000	3200	3420	3640	4180	4540	5080	5360	5520	5840		
	Dual (LBS.)	2000	2240	2430	2640	2820	3010	3200	3680	4000	4470	4720	4860	5140			
	Triple (LBS.)		1860	2080	2260	2460	2620	2800	2980	3430	3720	4170	4400	4530	4790		
380/85R46	Load Index															153	
	Single (LBS.)		NR	NR	3200	3420	3740	3960	4300	4800	5360	5840	6150	6400	6800	7600	8050
	Dual (LBS.)	2360	2560	2810	3010	3300	3490	3780	4230	4720	5140	5430	5620	5960	6690	7080	7520
	Triple (LBS.)		2200	2390	2620	2800	3070	3250	3530	3940	4400	4790	5040	5250	5580	6230	6600
380/90R46	Load Index								137		144		147	149			
	Single (LBS.)		NR	NR	3300	3640	3860	4180	4400	5080	5520	6150	6400	6800	7150		
	Dual (LBS.)	2490	2710	2900	3200	3400	3680	3870	4470	4860	5410	5630	5980	6290			
	Triple (LBS.)		2320	2530	2710	2980	3170	3430	3610	4170	4530	5040	5250	5580	5860		
380/90R50	Load Index								138		145		148	151			
	Single (LBS.)		NR	NR	3520	3740	4080	4400	4680	5200	5840	6400	6800	6950	7600		

NOTE: Single (LBS.) Not Recommended.

LOAD & INFLATION TABLE

(Pa)

Radial Ply Metric Size Agricultural Tractor Drive Wheel Tires
Used in Field Service and Speeds Up To 50 KPH

AT HIGHER TRANSPORT SPEEDS (ABOVE 30 KPH) AND LOWER PRESSURES (LESS THAN 0.8 BAR),
INCREASED INFLATION PRESSURE MAY BE REQUIRED FOR VEHICLE STABILITY.

Maximum Speed - 50 KPH (30 MPH)

Tire Size	TIRE LOAD LIMITS (KG) AT VARIOUS COLD INFLATION PRESSURES (kPa)																
	Inflation (kPa)	40	50	60	70	80	90	100	120	140	160	180	200	240	280	320	360
	Inflation (bar)	0.4	0.5	0.6	0.7	0.8	0.9	1.0	1.2	1.4	1.6	1.8	2.0	2.4	2.8	3.2	3.6
320/90R42	Load Index								126		133		136	139			
	Single (KG)	NR	NR	1120	1215	1320	1400	1500	1700	1900	2060	2180	2240	2430			
	Dual (KG)	835	905	985	1070	1160	1230	1320	1495	1670	1815	1920	1970	2140			
	Triple (KG)	780	845	920	995	1080	1150	1230	1395	1560	1690	1790	1835	1995			
320/90R46	Load Index								127		135		138	140	144	146	148
	Single (KG)	NR	NR	1180	1285	1360	1500	1550	1750	1950	2180	2300	2360	2500	2800	3000	3150
	Dual (KG)	860	960	1040	1130	1195	1320	1365	1540	1715	1920	2025	2075	2200	2465	2640	2770
	Triple (KG)	800	895	970	1055	1115	1230	1270	1435	1600	1790	1885	1935	2050	2295	2460	2585
320/90R50	Load Index								129		136		140	142	145	148	
	Single (KG)	NR	NR	1250	1320	1450	1550	1650	1850	2060	2240	2360	2500	2650	2900	3150	
	Dual (KG)	905	985	1100	1160	1275	1365	1450	1630	1815	1970	2075	2200	2330	2550	2770	
	Triple (KG)	845	920	1025	1080	1190	1270	1355	1515	1690	1835	1935	2050	2175	2380	2585	
320/90R54	Load Index								131		138		141	143	146	149	
	Single (KG)	NR	NR	1285	1400	1500	1600	1700	1950	2120	2360	2500	2575	2725	3000	3250	
	Dual (KG)	935	1040	1130	1230	1320	1410	1495	1715	1865	2075	2200	2265	2400	2640	2860	
	Triple (KG)	870	970	1055	1150	1230	1310	1395	1600	1740	1935	2050	2110	2235	2460	2665	
340/85R46	Load Index								129		136		140				
	Single (KG)	NR	NR	1250	1320	1450	1550	1650	1850	2060	2240	2360	2500				
	Dual (KG)	905	985	1100	1160	1275	1365	1450	1630	1815	1970	2075	2200				
	Triple (KG)	845	920	1025	1080	1190	1270	1355	1515	1690	1835	1935	2050				
380/85R28	Load Index								126		133						
	Single (KG)	NR	NR	1150	1215	1320	1400	1500	1700	1900	2060						
	Dual (KG)	835	905	1010	1070	1160	1230	1320	1495	1670	1815						
	Triple (KG)	780	845	945	995	1080	1150	1230	1395	1560	1690						
380/85R30	Load Index								127		135						
	Single (KG)	NR	NR	1180	1285	1360	1450	1550	1750	1950	2180						
	Dual (KG)	860	960	1040	1130	1195	1275	1365	1540	1715	1920						
	Triple (KG)	800	895	970	1055	1115	1190	1270	1435	1600	1790						
380/85R34	Load Index								129		137		140	142			
	Single (KG)	NR	NR	1250	1360	1450	1550	1650	1850	2060	2300	2430	2500	2650			
	Dual (KG)	905	1010	1100	1195	1275	1365	1450	1630	1815	2025	2140	2200	2330			
	Triple (KG)	845	945	1025	1115	1190	1270	1355	1515	1690	1885	1995	2050	2175			
380/80R38	Load Index								130		137		140	142			
	Single (KG)	NR	NR	1250	1360	1450	1550	1650	1900	2060	2300	2430	2500	2650			
	Dual (KG)	905	1010	1100	1195	1275	1365	1450	1670	1815	2025	2140	2200	2330			
	Triple (KG)	845	945	1025	1115	1190	1270	1355	1560	1690	1885	1995	2050	2175			
380/85R46	Load Index															153	
	Single (KG)	NR	NR	1450	1500	1700	1800	1950	2180	2430	2650	2800	2900	3075	3450	3650	3875
	Dual (KG)	1070	1160	1275	1365	1495	1585	1715	1920	2140	2330	2465	2550	2705	3035	3210	3410
	Triple (KG)	1000	1080	1190	1270	1390	1480	1600	1790	1990	2170	2300	2380	2520	2830	2990	3180
380/90R46	Load Index								137		144		147	149			
	Single (KG)	NR	NR	1500	1650	1750	1900	2000	2300	2500	2800	2900	3075	3250			
	Dual (KG)	1130	1230	1320	1450	1540	1670	1760	2025	2200	2465	2550	2705	2860			
	Triple (KG)	1055	1150	1230	1355	1435	1560	1640	1885	2050	2295	2380	2520	2665			
380/90R50	Load Index								138		145		148	151			
	Single (KG)	NR	NR	1600	1700	1850	2000	2120	2360	2650	2900	3075	3150	3450			
	Dual (KG)	1160	1275	1410	1495	1630	1760	1865	2075	2330	2550	2705	2770	3035			
	Triple (KG)	1080	1190	1310	1395	1515	1640	1740	1935	2175	2380	2520	2585	2830			

NOTE: NR Not Recommended.

LOAD & INFLATION TABLE

PSI)

Radial Ply Metric Size Agricultural Tractor Drive Wheel Tires
Used in Field Service and Speeds Up To 30 KPH

AT HIGHER TRANSPORT SPEEDS (ABOVE 20 MPH) AND LOWER PRESSURES (LESS THAN 12 PSI),
INCREASED INFLATION PRESSURE MAY BE REQUIRED FOR VEHICLE STABILITY.

Maximum Speed - 30 MPH

Tire Size	TIRE LOAD LIMITS (LBS.) AT VARIOUS COLD INFLATION PRESSURES (PSI)																
	Inflation (psi)	6	7	9	10	12	13	15	17	20	23	26	29	35	41	46	52
380/90R54	Load Index								140		146		150	152			
	Single (LBS.)		3000	3300	3640	3960	4300	4540	4800	5520	6000	6600	6950	7400	7850		
	Dual (LBS.)	2640	2900	3200	3480	3780	4000	4220	4860	5280	5810	6120	6510	6910			
	Triple (LBS.)		2460	2710	2980	3250	3530	3720	3940	4530	4920	5410	5700	6070	6440		
420/70R24	Load Index								123		130						
	Single (LBS.)		NR	NR	2270	2470	2680	2910	3080	3420	3860	4180					
	Dual (LBS.)	1700	1840	2000	2170	2360	2560	2710	3010	3400	3680						
	Triple (LBS.)		1580	1710	1860	2030	2200	2390	2530	2800	3170	3430					
420/70R28	Load Index								126		133						
	Single (LBS.)		NR	NR	2470	2680	2910	3080	3300	3740	4080	4540					
	Dual (LBS.)	1800	2000	2170	2360	2560	2710	2900	3290	3590	4000						
	Triple (LBS.)		1670	1860	2030	2200	2390	2530	2710	3070	3350	3720					
420/85R28	Load Index								132		139						
	Single (LBS.)		NR	NR	2910	3200	3420	3640	3860	4400	4940	5360					
	Dual (LBS.)	2170	2360	2560	2820	3010	3200	3400	3870	4350	4720						
	Triple (LBS.)		2030	2200	2390	2620	2800	2980	3170	3610	4050	4400					
420/90R30	Load Index								135		142						
	Single (LBS.)		NR	NR	3200	3420	3740	3960	4180	4800	5360	5840					
	Dual (LBS.)	2360	2560	2820	3010	3290	3480	3680	4220	4720	5140						
	Triple (LBS.)		2200	2390	2620	2800	3070	3250	3430	3940	4400	4790					
420/85R34	Load Index								135		142		145	147			
	Single (LBS.)		NR	NR	3200	3420	3740	3960	4300	4800	5360	5840	6150	6400	6800		
	Dual (LBS.)	2360	2560	2820	3010	3290	3480	3780	4220	4720	5140	5410	5630	5980			
	Triple (LBS.)		2200	2390	2620	2800	3070	3250	3530	3940	4400	4790	5040	5250	5580		
420/80R46	Load Index								139		145		149	151	154	156	159
9650	Single (LBS.)		NR	NR	3520	3860	4080	4400	4680	5360	5840	6400	6800	7150	7600	8250	8800
	Dual (LBS.)	2560	2820	3100	3400	3590	3870	4120	4720	5140	5630	5980	6290	6690	7260	7740	8490
7910	Triple (LBS.)		2390	2620	2890	3170	3350	3610	3840	4400	4790	5250	5580	5860	6230	6770	7220
440	80R28 Load Index								132		140						
	Single (LBS.)		NR	NR	3000	3200	3520	3740	3960	4400	4940	5520					
	Dual (LBS.)	2170	2430	2640	2820	3100	3290	3480	3870	4350	4860						
	Triple (LBS.)		2030	2260	2460	2620	2890	3070	3250	3610	4050	4530					
480	70R28 Load Index								133		140						
	Single (LBS.)		NR	NR	3000	3300	3520	3740	4080	4540	5080	5520					
	Dual (LBS.)	2240	2430	2640	2900	3100	3290	3590	4000	4470	4860						
	Triple (LBS.)		2080	2260	2460	2710	2890	3070	3350	3720	4170	4530					
480	70R30 Load Index								134		141		145	147	150	152	
	Single (LBS.)		NR	NR	3080	3420	3640	3960	4180	4680	5200	5680	6000	6400	6800	7400	7850
	Dual (LBS.)	2290	2490	2710	3010	3200	3480	3680	4120	4580	5000	5280	5630	5980	6510	6910	
	Triple (LBS.)		2130	2320	2530	2800	2980	3250	3430	3840	4260	4660	4920	5250	5580	6070	6440
480	70R34 Load Index								136		143		146	149	152	155	
	Single (LBS.)		NR	NR	3300	3640	3860	4180	4400	4940	5520	6000	6400	6600	7150	7850	8550
	Dual (LBS.)	2430	2710	2900	3200	3400	3680	3870	4350	4860	5280	5630	5810	6290	6910	7520	

NOTE: NR Not Recommended.

LOAD & INFLATION TABLE

(Pa)

Radial Ply Metric Size Agricultural Tractor Drive Wheel Tires
Used in Field Service and Speeds Up To 50 KPH

AT HIGHER TRANSPORT SPEEDS (ABOVE 30 KPH) AND LOWER PRESSURES (LESS THAN 0.8 BAR),
INCREASED INFLATION PRESSURE MAY BE REQUIRED FOR VEHICLE STABILITY.

Maximum Speed - 50 KPH (30 MPH)

Tire Size	TIRE LOAD LIMITS (KG) AT VARIOUS COLD INFLATION PRESSURES (kPa)																
	Inflation (kPa)	40	50	60	70	80	90	100	120	140	160	180	200	240	280	320	360
	Inflation (bar)	0.4	0.5	0.6	0.7	0.8	0.9	1.0	1.2	1.4	1.6	1.8	2.0	2.4	2.8	3.2	3.6
380/90R54	Load Index								140		146		150	152			
	Single (KG)	NR	NR	1650	1800	1950	2060	2180	2500	2725	3000	3150	3350	3550			
	Dual (KG)	1195	1320	1450	1585	1715	1815	1920	2200	2400	2640	2770	2950	3125			
	Triple (KG)	1115	1230	1355	1475	1600	1690	1790	2050	2235	2460	2585	2745	2910			
420/70R24	Load Index								123		130						
	Single (KG)	NR	NR	1030	1120	1215	1320	1400	1550	1750	1900						
	Dual (KG)	770	835	905	985	1070	1160	1230	1365	1540	1670						
	Triple (KG)	720	780	845	920	995	1080	1150	1270	1435	1560						
420/70R28	Load Index								126		133						
	Single (KG)	NR	NR	1120	1215	1320	1400	1500	1700	1850	2060						
	Dual (KG)	815	905	985	1070	1160	1230	1320	1495	1630	1815						
	Triple (KG)	760	845	920	995	1080	1150	1230	1395	1515	1690						
420/85R28	Load Index								132		139						
	Single (KG)	NR	NR	1320	1450	1550	1650	1750	2000	2240	2430						
	Dual (KG)	985	1070	1160	1275	1365	1450	1540	1760	1970	2140						
	Triple (KG)	920	995	1080	1190	1270	1355	1435	1640	1835	1995						
420/90R30	Load Index								135		142						
	Single (KG)	NR	NR	1450	1550	1700	1800	1900	2180	2430	2650						
	Dual (KG)	1070	1160	1275	1365	1495	1585	1670	1920	2140	2330						
	Triple (KG)	995	1080	1190	1270	1395	1475	1560	1790	1995	2175						
420/85R34	Load Index								135		142		145	147			
	Single (KG)	NR	NR	1450	1550	1700	1800	1950	2180	2430	2650	2800	2900	3075			
	Dual (KG)	1070	1160	1275	1365	1495	1585	1715	1920	2140	2330	2465	2550	2705			
	Triple (KG)	995	1080	1190	1270	1395	1475	1600	1790	1995	2175	2295	2380	2520			
420/80R46	Load Index								139		145		149	151	154	156	159
	Single (KG)	NR	NR	1600	1750	1850	2000	2120	2430	2650	2900	3075	3250	3450	3750	4000	4375
	Dual (KG)	1160	1275	1410	1540	1630	1760	1865	2140	2330	2550	2705	2860	3035	3300	3520	3850
	Triple (KG)	1080	1190	1310	1435	1515	1640	1740	1995	2175	2380	2520	2665	2830	3075	3280	3590
440/80R28	Load Index								132		140						
	Single (KG)	NR	NR	1360	1450	1600	1700	1800	2000	2240	2500						
	Dual (KG)	985	1100	1195	1275	1410	1495	1585	1760	1970	2200						
	Triple (KG)	920	1025	1115	1190	1310	1395	1475	1640	1835	2050						
480/70R28	Load Index								133		140						
	Single (KG)	NR	NR	1360	1500	1600	1700	1850	2060	2300	2500						
	Dual (KG)	1010	1100	1195	1320	1410	1495	1630	1815	2025	2200						
	Triple (KG)	945	1025	1115	1230	1310	1395	1515	1690	1885	2050						
480/70R30	Load Index								134		141		145	147	150	152	
	Single (KG)	NR	NR	1400	1550	1650	1800	1900	2120	2360	2575	2725	2900	3075	3350	3550	
	Dual (KG)	1040	1130	1230	1365	1450	1585	1670	1865	2075	2265	2400	2550	2705	2950	3125	
	Triple (KG)	970	1055	1150	1270	1355	1475	1560	1740	1935	2110	2235	2380	2520	2745	2910	
480/70R34	Load Index								136		143		146	149	152	155	
	Single (KG)	NR	NR	1500	1650	1750	1900	2000	2240	2500	2725	2900	3000	3250	3550	3875	
	Dual (KG)	1100	1230	1320	1450	1540	1670	1760	1970	2200	2400	2550	2640	2860	3125	3410	
	Triple (KG)	1025	1150	1230	1355	1435	1560	1640	1835	2050	2235	2380	2460	2665	2910	3180	

NOTE: NR Not Recommended.

LOAD & INFLATION TABLE

PSI)

Radial Ply Metric Size Agricultural Tractor Drive Wheel Tires
Used in Field Service and Speeds Up To 30 KPH

AT HIGHER TRANSPORT SPEEDS (ABOVE 20 MPH) AND LOWER PRESSURES (LESS THAN 12 PSI),
INCREASED INFLATION PRESSURE MAY BE REQUIRED FOR VEHICLE STABILITY.

Maximum Speed - 30 MPH

Tire Size	TIRE LOAD LIMITS (LBS.) AT VARIOUS COLD INFLATION PRESSURES (PSI)																
	Inflation (psi)	6	7	9	10	12	13	15	17	20	23	26	29	35	41	46	52
480/85R34	Load Index								142		149						
	Single (LBS.)		NR	NR	3960	4300	4540	4940	5200	5840	6600	7150					
	Dual (LBS.)	2900	3200	3480	3780	4000	4350	4580	5140	5810	6290						
	Triple (LBS.)		2710	2980	3250	3530	3720	4050	4260	4790	5410	5860					
480/80R38	Load Index								142		149						
	Single (LBS.)		NR	NR	3960	4300	4540	4940	5200	5840	6600	7150					
	Dual (LBS.)	2900	3200	3480	3780	4000	4350	4580	5140	5810	6290						
	Triple (LBS.)		2710	2980	3250	3530	3720	4050	4260	4790	5410	5860					
480/80R42	Load Index								144		151						
	Single (LBS.)		NR	NR	4080	4400	4800	5200	5520	6150	6950	7600					
	Dual (LBS.)	3010	3290	3590	3870	4220	4580	4860	5410	6120	6690						
	Triple (LBS.)		2800	3070	3350	3610	3940	4260	4530	5040	5700	6230					
480/80R46	Load Index								145		152		155	158			
	Single (LBS.)		NR	NR	4300	4680	5080	5360	5680	6400	7150	7850	8250	8550	9350		
	Dual (LBS.)	3200	3480	3780	4120	4470	4720	5000	5630	6290	6910	7260	7520	8230			
	Triple (LBS.)		2980	3250	3530	3840	4170	4400	4660	5250	5860	6440	6770	7010	7670		
480/80R50	Load Index								147		154		157	159			
	Single (LBS.)		NR	NR	4540	4940	5200	5680	6000	6800	7600	8250	8550	9100	9650		
	Dual (LBS.)	3290	3590	4000	4350	4580	5000	5280	5980	6690	7260	7520	8010	8490			
	Triple (LBS.)		3070	3350	3720	4050	4260	4660	4920	5580	6230	6770	7010	7460	7910		
520/85R38	Load Index								148		155						
	Single (LBS.)		NR	NR	4680	5080	5520	5840	6150	6950	7850	8550					
	Dual (LBS.)	3400	3780	4120	4470	4860	5140	5410	6120	6910	7520						
	Triple (LBS.)		3170	3530	3840	4170	4530	4790	5040	5700	6440	7010					
520/85R42	Load Index								150		157						
	Single (LBS.)		NR	NR	4940	5360	5680	6150	6600	7400	8250	9100					
	Dual (LBS.)	3590	4000	4350	4720	5000	5410	5810	6510	7260	8010						
	Triple (LBS.)		3350	3720	4050	4400	4660	5040	5410	6070	6770	7460					
520/85R46	Load Index								151		158						
	Single (LBS.)		NR	NR	5080	5520	6000	6400	6800	7600	8550	9350					
	Dual (LBS.)	3780	4120	4470	4860	5280	5630	5980	6690	7520	8230						
	Triple (LBS.)		3530	3840	4170	4530	4920	5250	5580	6230	7010	7670					
540/65R30	Load Index								138		143		147	150			
	Single (LBS.)		NR	NR	3420	3740	3960	4300	4540	5200	5680	6000	6400	6800	7400		
	Dual (LBS.)	2490	2710	3010	3290	3480	3780	4000	4580	5000	5280	5630	5980	6510			
	Triple (LBS.)		2320	2530	2800	3070	3250	3530	3720	4260	4660	4920	5250	5580	6070		
540/65R34	Load Index								140		145		149	152			
	Single (LBS.)		NR	NR	3640	3960	4180	4540	4800	5520	6000	6400	6800	7150	7850		
	Dual (LBS.)	2640	2900	3200	3480	3680	4000	4220	4860	5280	5630	5980	6290	6910			
	Triple (LBS.)		2460	2710	2980	3250	3430	3720	3940	4530	4920	5250	5580	5860	6440		
540/75R34	Load Index								145		152		155	157			
	Single (LBS.)		NR	NR	4180	4540	4940	5360	5680	6400	6950	7850	8050	8550	9100		
	Dual (LBS.)	3100	3400	3680	4000	4350	4720	5000	5630	6120	6910	7080	7520	8010			
	Triple (LBS.)		2890	3170	3430	3720	4050	4400	4660	5250	5700	6440	6600	7010	7460		

NOTE: NR Not Recommended.

LOAD & INFLATION TABLE

(Pa)

Radial Ply Metric Size Agricultural Tractor Drive Wheel Tires
Used in Field Service and Speeds Up To 50 KPH

AT HIGHER TRANSPORT SPEEDS (ABOVE 30 KPH) AND LOWER PRESSURES (LESS THAN 0.8 BAR),
INCREASED INFLATION PRESSURE MAY BE REQUIRED FOR VEHICLE STABILITY.

Maximum Speed - 50 KPH (30 MPH)

Tire Size	TIRE LOAD LIMITS (KG) AT VARIOUS COLD INFLATION PRESSURES (kPa)																
	Inflation (kPa)	40	50	60	70	80	90	100	120	140	160	180	200	240	280	320	360
	Inflation (bar)	0.4	0.5	0.6	0.7	0.8	0.9	1.0	1.2	1.4	1.6	1.8	2.0	2.4	2.8	3.2	3.6
480/85R34	Load Index								142	149							
	Single (KG)	NR	NR	1800	1950	2060	2240	2360	2650	3000	3250						
	Dual (KG)	1320	1450	1585	1715	1815	1970	2075	2330	2640	2860						
	Triple (KG)	1230	1355	1475	1600	1690	1835	1935	2175	2460	2665						
480/80R38	Load Index								142	149							
	Single (KG)	NR	NR	1800	1950	2060	2240	2360	2650	3000	3250						
	Dual (KG)	1320	1450	1585	1715	1815	1970	2075	2330	2640	2860						
	Triple (KG)	1230	1355	1475	1600	1690	1835	1935	2175	2460	2665						
480/80R42	Load Index								144	151							
	Single (KG)	NR	NR	1850	2000	2180	2360	2500	2800	3150	3450						
	Dual (KG)	1365	1495	1630	1760	1920	2075	2200	2465	2770	3035						
	Triple (KG)	1270	1395	1515	1640	1790	1935	2050	2295	2585	2830						
480/80R46	Load Index								145	152		155	158				
	Single (KG)	NR	NR	1950	2120	2300	2430	2575	2900	3250	3550	3750	3875	4250			
	Dual (KG)	1450	1585	1715	1865	2025	2140	2265	2550	2860	3125	3300	3410	3740			
	Triple (KG)	1355	1475	1600	1740	1885	1995	2110	2380	2665	2910	3075	3180	3485			
480/80R50	Load Index								147	154		157	159				
	Single (KG)	NR	NR	2060	2240	2360	2575	2725	3075	3450	3750	3875	4125	4375			
	Dual (KG)	1495	1630	1815	1970	2075	2265	2400	2705	3035	3300	3410	3630	3850			
	Triple (KG)	1395	1515	1690	1835	1935	2110	2235	2520	2830	3075	3180	3385	3590			
520/85R38	Load Index								148	155							
	Single (KG)	NR	NR	2120	2300	2500	2650	2800	3150	3550	3875						
	Dual (KG)	1540	1715	1865	2025	2200	2330	2465	2770	3125	3410						
	Triple (KG)	1435	1600	1740	1885	2050	2175	2295	2585	2910	3180						
520/85R42	Load Index								150	157							
	Single (KG)	NR	NR	2240	2430	2575	2800	3000	3350	3750	4125						
	Dual (KG)	1630	1815	1970	2140	2265	2465	2640	2950	3300	3630						
	Triple (KG)	1515	1690	1835	1995	2110	2295	2460	2745	3075	3385						
520/85R46	Load Index								151	158							
	Single (KG)	NR	NR	2300	2500	2725	2900	3075	3450	3875	4250						
	Dual (KG)	1715	1865	2025	2200	2400	2550	2705	3035	3410	3740						
	Triple (KG)	1600	1740	1885	2050	2235	2380	2520	2830	3180	3485						
540/65R30	Load Index								138	143		147	150				
	Single (KG)	NR	NR	1550	1700	1800	1950	2060	2360	2575	2725	2900	3075	3350			
	Dual (KG)	1130	1230	1365	1495	1585	1715	1815	2075	2265	2400	2550	2705	2950			
	Triple (KG)	1055	1150	1270	1395	1475	1600	1690	1935	2110	2235	2380	2520	2745			
540/65R34	Load Index								140	145		149	152				
	Single (KG)	NR	NR	1650	1800	1900	2060	2180	2500	2725	2900	3075	3250	3550			
	Dual (KG)	1195	1320	1450	1585	1670	1815	1920	2200	2400	2550	2705	2860	3125			
	Triple (KG)	1115	1230	1355	1475	1560	1690	1790	2050	2235	2380	2520	2665	2910			
540/75R34	Load Index								145	152		155	157				
	Single (KG)	NR	NR	1900	2060	2240	2430	2575	2900	3150	3550	3650	3875	4125			
	Dual (KG)	1410	1540	1670	1815	1970	2140	2265	2550	2770	3125	3210	3410	3630			
	Triple (KG)	1310	1435	1560	1690	1835	1995	2110	2380	2585	2910	2995	3180	3385			

NOTE: NR Not Recommended.

LOAD & INFLATION TABLE

PSI)

Radial Ply Metric Size Agricultural Tractor Drive Wheel Tires
Used in Field Service and Speeds Up To 30 KPH

AT HIGHER TRANSPORT SPEEDS (ABOVE 20 MPH) AND LOWER PRESSURES (LESS THAN 12 PSI),
INCREASED INFLATION PRESSURE MAY BE REQUIRED FOR VEHICLE STABILITY.

Maximum Speed - 30 MPH

Tire Size	Inflation (psi)	TIRE LOAD LIMITS (LBS.) AT VARIOUS COLD INFLATION PRESSURES (PSI)															
		6	7	9	10	12	13	15	17	20	23	26	29	35	41	46	52
580/70R38	Load Index								148		155						
	Single (LBS.)		NR	NR	4680	5080	5520	5840	6150	6950	7850	8550					
	Dual (LBS.)	3400	3780	4120	4470	4860	5140	5410	6120	6910	7520						
	Triple (LBS.)		3170	3530	3840	4170	4530	4790	5040	5700	6440	7010					
600/65R28	Load Index								142		147						
	Single (LBS.)		NR	NR	3860	4180	4540	4940	5200	5840	6400	6800					
	Dual (LBS.)	2900	3100	3400	3680	4000	4350	4580	5140	5630	5980						
	Triple (LBS.)		2710	2890	3170	3430	3720	4050	4260	4790	5250	5580					
600/70R30	Load Index								146		152						
	Single (LBS.)		NR	NR	4400	4800	5200	5520	5840	6600	7400	7850					
	Dual (LBS.)	3200	3590	3870	4220	4580	4860	5140	5810	6510	6910						
	Triple (LBS.)		2980	3350	3610	3940	4260	4530	4790	5410	6070	6440					
620/75R26	Load Index								148		153		158	160	164	166	
	Single (LBS.)		NR	NR	4680	5080	5520	5840	6150	6950	7850	8050	9100	9350	9900	11000	11700
	Dual (LBS.)	3400	3780	4120	4470	4860	5140	5410	6120	6910	7080	8010	8230	8710	9680	10300	
	Triple (LBS.)		3170	3530	3840	4170	4530	4790	5040	5700	6440	6600	7460	7670	8120	9020	9590
620/70R42	Load Index								153		160						
	Single (LBS.)		NR	NR	5360	5840	6400	6800	7150	8050	9100	9900					
	Dual (LBS.)	4000	4350	4720	5140	5630	5980	6290	7080	8010	8710						
	Triple (LBS.)		3720	4050	4400	4790	5250	5580	5860	6600	7460	8120					
620/70R46	Load Index								155		162						
	Single (LBS.)		NR	NR	5680	6150	6600	7150	7600	8550	9350	10500					
	Dual (LBS.)	4120	4580	5000	5410	5810	6290	6690	7520	8230	9240						
	Triple (LBS.)		3840	4260	4660	5040	5410	5860	6230	7010	7670	8610					
650/75R32	Load Index								154		160		164	167	169	172	
	Single (LBS.)		NR	NR	5520	6000	6400	6950	7400	8250	9100	9900	10700	11000	12000	12800	13900
	Dual (LBS.)	4000	4470	4860	5280	5630	6120	6510	7260	8010	8710	9420	9680	10560	11260	12230	
	Triple (LBS.)		3720	4170	4530	4920	5250	5700	6070	6770	7460	8120	8770	9020	9840	10500	11400
650/85R38	Load Index								160		167		170	173			
	Single (LBS.)		NR	NR	6600	7150	7850	8250	8800	9900	11000	12000	12800	13200	14300		
	Dual (LBS.)	4860	5280	5810	6290	6910	7260	7740	8710	9680	10560	11260	11620	12580			
	Triple (LBS.)		4530	4920	5410	5860	6440	6770	7220	8120	9020	9840	10500	10820	11730		
650/65R42	Load Index								153		158		162	165	168	170	
	Single (LBS.)		NR	NR	5360	5840	6150	6600	7150	8050	8800	9350	9900	10500	11400	12300	13200
	Dual (LBS.)	3870	4350	4720	5140	5410	5810	6290	7080	7740	8230	8710	9240	10030	10820	11620	
	Triple (LBS.)		3610	4050	4400	4790	5040	5410	5860	6600	7220	7670	8120	8610	9350	10090	10820
710/70R38	Load Index								159		166						
	Single (LBS.)		NR	NR	6400	6950	7400	8050	8550	9650	10700	11700					
	Dual (LBS.)	4720	5140	5630	6120	6510	7080	7520	8490	9420	10300						
	Triple (LBS.)		4400	4790	5250	5700	6070	6600	7010	7910	8770	9590					
710/70R42	Load Index								160		168						
	Single (LBS.)		NR	NR	6600	7150	7850	8250	8800	9900	11000	12300					
	Dual (LBS.)	4860	5410	5810	6290	6910	7260	7740	8710	9680	10820						
	Triple (LBS.)		4530	5040	5410	5860	6440	6770	7220	8120	9020	10090					

NOTE: NR Not Recommended.

LOAD & INFLATION TABLE

(Pa)

Radial Ply Metric Size Agricultural Tractor Drive Wheel Tires
Used in Field Service and Speeds Up To 50 KPH

AT HIGHER TRANSPORT SPEEDS (ABOVE 30 KPH) AND LOWER PRESSURES (LESS THAN 0.8 BAR),
INCREASED INFLATION PRESSURE MAY BE REQUIRED FOR VEHICLE STABILITY.

Maximum Speed - 50 KPH (30 MPH)

Tire Size	TIRE LOAD LIMITS (KG) AT VARIOUS COLD INFLATION PRESSURES (kPa)																
	Inflation (kPa)	40	50	60	70	80	90	100	120	140	160	180	200	240	280	320	360
	Inflation (bar)	0.4	0.5	0.6	0.7	0.8	0.9	1.0	1.2	1.4	1.6	1.8	2.0	2.4	2.8	3.2	3.6
580/70R38	Load Index								148		155						
	Single (KG)	NR	NR	2120	2300	2500	2650	2800	3150	3550	3875						
	Dual (KG)	1540	1715	1865	2025	2200	2330	2465	2770	3125	3410						
	Triple (KG)	1435	1600	1740	1885	2050	2175	2295	2585	2910	3180						
600/65R28	Load Index								142		147						
	Single (KG)	NR	NR	1750	1900	2060	2240	2360	2650	2900	3075						
	Dual (KG)	1320	1410	1540	1670	1815	1970	2075	2330	2550	2705						
	Triple (KG)	1230	1310	1435	1560	1690	1835	1935	2175	2380	2520						
600/70R30	Load Index								146		152						
	Single (KG)	NR	NR	2000	2180	2360	2500	2650	3000	3350	3550						
	Dual (KG)	1450	1630	1760	1920	2075	2200	2330	2640	2950	3125						
	Triple (KG)	1355	1515	1640	1790	1935	2050	2175	2460	2745	2910						
620/75R26	Load Index								148		153		158	160	164	166	
	Single (KG)	NR	NR	2120	2300	2500	2650	2800	3150	3550	3650	4125	4250	4500	5000	5300	
	Dual (KG)	1540	1715	1865	2025	2200	2330	2465	2770	3125	3210	3630	3740	3960	4400	4665	
	Triple (KG)	1435	1600	1740	1885	2050	2175	2295	2585	2910	2995	3385	3485	3690	4100	4345	
620/70R42	Load Index								153		160						
	Single (KG)	NR	NR	2430	2650	2900	3075	3250	3650	4125	4500						
	Dual (KG)	1815	1970	2140	2330	2550	2705	2860	3210	3630	3960						
	Triple (KG)	1690	1835	1995	2175	2380	2520	2665	2995	3385	3690						
620/70R46	Load Index								155		162						
	Single (KG)	NR	NR	2575	2800	3000	3250	3450	3875	4250	4750						
	Dual (KG)	1865	2075	2265	2465	2640	2860	3035	3410	3740	4180						
	Triple (KG)	1740	1935	2110	2295	2460	2665	2830	3180	3485	3895						
650/75R32	Load Index								154		160		164	167	169	172	
	Single (KG)	NR	NR	2500	2725	2900	3150	3350	3750	4125	4500	4875	5000	5450	5800	6300	
	Dual (KG)	1815	2025	2200	2400	2550	2770	2950	3300	3630	3960	4290	4400	4795	5105	5545	
	Triple (KG)	1690	1885	2050	2235	2380	2585	2745	3075	3385	3690	4000	4100	4470	4755	5165	
650/85R38	Load Index								160		167		170	173			
	Single (KG)	NR	NR	3000	3250	3550	3750	4000	4500	5000	5450	5800	6000	6500			
	Dual (KG)	2200	2400	2640	2860	3125	3300	3520	3960	4400	4795	5105	5280	5720			
	Triple (KG)	2050	2235	2460	2665	2910	3075	3280	3690	4100	4470	4755	4920	5330			
650/65R42	Load Index								153		158		162	165	168	170	
	Single (KG)	NR	NR	2430	2650	2800	3000	3250	3650	4000	4250	4500	4750	5150	5600	6000	
	Dual (KG)	1760	1970	2140	2330	2465	2640	2860	3210	3520	3740	3960	4180	4530	4930	5280	
	Triple (KG)	1640	1835	1995	2175	2295	2460	2665	2995	3280	3485	3690	3895	4225	4590	4920	
710/70R38	Load Index								159		166						
	Single (KG)	NR	NR	2900	3150	3350	3650	3875	4375	4875	5300						
	Dual (KG)	2140	2330	2550	2770	2950	3210	3410	3850	4290	4665						
	Triple (KG)	1995	2175	2380	2585	2745	2995	3180	3590	4000	4345						
710/70R42	Load Index								160		168						
	Single (KG)	NR	NR	3000	3250	3550	3750	4000	4500	5000	5600						
	Dual (KG)	2200	2465	2640	2860	3125	3300	3520	3960	4400	4930						
	Triple (KG)	2050	2295	2460	2665	2910	3075	3280	3690	4100	4590						

NOTE: NR Not Recommended.

LOAD & INFLATION TABLE

PSI)

Radial Ply Metric Size Agricultural Tractor Drive Wheel Tires
Used in Field Service and Speeds Up To 30 KPH

AT HIGHER TRANSPORT SPEEDS (ABOVE 20 MPH) AND LOWER PRESSURES (LESS THAN 12 PSI),
INCREASED INFLATION PRESSURE MAY BE REQUIRED FOR VEHICLE STABILITY.

Maximum Speed - 30 MPH

Tire Size	Inflation (psi)	TIRE LOAD LIMITS (LBS.) AT VARIOUS COLD INFLATION PRESSURES (PSI)															
		6	7	9	10	12	13	15	17	20	23	26	29	35	41	46	52
800/65R32	Load Index								159		167		169	172			
	Single (LBS.)	NR	NR	6600	6950	7600	8050	8800	9650	10700	12000	12300	12800	13900			
	Dual (LBS.)	4720	5280	5810	6120	6690	7080	7740	8490	9420	10560	10820	11260	12230			
	Triple (LBS.)	4400	4920	5410	5700	6230	6600	7220	7910	8770	9840	10090	10500	11400			
800/70R38	Load Index								166		173						
	Single (LBS.)	NR	NR	7600	8250	9100	9650	10200	11700	12800	14300						
	Dual (LBS.)	5630	6290	6690	7260	8010	8490	8980	10300	11260	12580						
	Triple (LBS.)	5250	5860	6230	6770	7460	7910	8360	9590	10500	11730						
900/65R32	Load Index								166		172						
	Single (LBS.)	NR	NR	7850	8550	9100	9900	10500	11700	12800	13900						
	Dual (LBS.)	5810	6290	6910	7520	8010	8710	9240	10300	11260	12230						
900/50R42	Load Index								161		168						
	Single (LBS.)	NR	NR	6800	7400	7850	8550	9100	10200	11400	12300						
	Dual (LBS.)	5000	5410	5980	6510	6910	7520	8010	8980	10030	10820						

- NOTES 1. For shipping purposes, tire inflation pressures may be increased to 30 psi (consult tire manufacturer for minimum tire shipping pressure). Inflation pressure must be reduced operating inflation before the tractor is removed from the carrier.
2. For above tires used in cyclic loading service (excluding hillside combines) without sustained high torque with speeds up to 5 MPH, above loads may be increased 70% (with 6 psi increase in inflation pressure). This load increase is also applicable to tires used on vehicles with mechanism capable of maintaining tires and wheels in a vertical position on slopes up to 11 (20% grade). Due to higher pressure specified for these tires, the rim and wheel manufacturers must be consulted.
3. For transport service and operations which do not require sustained high torque, the following load limits at various speeds apply with no change in inflation pressure:

MAXIMUM SPEED	% CHANGE IN LOADS IN ABOVE TABLE
10 MPH	+34% (except Hillside Combines)
15 MPH	+11% (except Hillside Combines)
20 MPH	+7%
25 MPH	NONE
30 MPH	NONE

4. NR Not Recommended.

Maximum Speed - 40 MPH

Tire Size	Inflation (psi)	TIRE LOAD LIMITS (LBS.) AT VARIOUS COLD INFLATION PRESSURES (PSI)															
		6	7	9	10	12	13	15	17	20	23	26	29	35	41	46	52
320/85R34	Load Index																146
	Single (LBS.)	NR	NR	1760	1870	2040	2200	2340	2600	2830	3080	3300	3520	3740	4080	4400	
	Dual (LBS.)	1260	1380	1550	1650	1800	1940	2060	2290	2490	2710	2900	3100	3290	3590	3870	
	Triple (LBS.)	1170	1290	1440	1530	1670	1800	1920	2130	2320	2530	2710	2890	3070	3350	3610	
380/85R46	Load Index																146
	Single (LBS.)	NR	NR	2600	2760	3000	3200	3520	3960	4400	4800	5080	5200	5520	6150	6600	
	Dual (LBS.)	1940	2110	2290	2430	2640	2820	3100	3480	3870	4220	4470	4580	4860	5410	5810	
	Triple (LBS.)	1800	1970	2130	2260	2460	2620	2890	3250	3610	3940	4170	4260	4530	5040	5410	

LOAD & INFLATION TABLE

(Pa)

Radial Ply Metric Size Agricultural Tractor Drive Wheel Tires
Used in Field Service and Speeds Up To 50 KPH

AT HIGHER TRANSPORT SPEEDS (ABOVE 30 KPH) AND LOWER PRESSURES (LESS THAN 0.8 BAR),
INCREASED INFLATION PRESSURE MAY BE REQUIRED FOR VEHICLE STABILITY.

Maximum Speed - 50 KPH (30 MPH)

Tire Size		TIRE LOAD LIMITS (KG) AT VARIOUS COLD INFLATION PRESSURES (kPa)																
		Inflation (kPa)	40	50	60	70	80	90	100	120	140	160	180	200	240	280	320	360
		Inflation (bar)	0.4	0.5	0.6	0.7	0.8	0.9	1.0	1.2	1.4	1.6	1.8	2.0	2.4	2.8	3.2	3.6
800/65R32	Load Index									159		167		169	172			
	Single (KG)	NR	NR	3000	3150	3450	3650	4000	4375	4875	5450	5600	5800	6300				
	Dual (KG)	2140	2400	2640	2770	3035	3210	3520	3850	4290	4795	4930	5105	5545				
	Triple (KG)	1995	2235	2460	2585	2830	2995	3280	3590	4000	4470	4590	4755	5165				
800/70R38	Load Index									166		173						
	Single (KG)	NR	NR	3450	3750	4125	4375	4625	5300	5800	6500							
	Dual (KG)	2550	2860	3035	3300	3630	3850	4070	4665	5105	5720							
	Triple (KG)	2380	2665	2830	3075	3385	3590	3795	4345	4755	5330							
900/65R32	Load Index									166		172						
	Single (KG)	NR	NR	3550	3875	4125	4500	4750	5300	5800	6300							
	Dual (KG)	2640	2860	3125	3410	3630	3960	4180	4665	5105	5545							
900/50R42	Load Index									161		168						
	Single (KG)	NR	NR	3075	3350	3550	3875	4125	4625	5150	5600							
	Dual (KG)	2265	2465	2705	2950	3125	3410	3630	4070	4530	4930							

- NOTES 1. For shipping purposes, tire inflation pressures may be increased to 30 psi (consult tire manufacturer for minimum tire shipping pressure). Inflation pressure must be reduced operating inflation before the tractor is removed from the carrier.
2. For above tires used in cyclic loading service (excluding hillside combines) without sustained high torque with speeds up to 5 MPH, above loads may be increased 70% (with 6 psi increase in inflation pressure). This load increase is also applicable to tires used on vehicles with mechanism capable of maintaining tires and wheels in a vertical position on slopes up to 11 (20% grade). Due to higher pressure specified for these tires, the rim and wheel manufacturers must be consulted.
3. For transport service and operations which do not require sustained high torque, the following load limits at various speeds apply with no change in inflation pressure:

MAXIMUM SPEED	% CHANGE IN LOADS IN ABOVE TABLE
10 MPH	+34% (except Hillside Combines)
15 MPH	+11% (except Hillside Combines)
20 MPH	+7%
25 MPH	NONE
30 MPH	NONE

4. NR Not Recommended.

Maximum Speed - 65 KPH

Tire Size		TIRE LOAD LIMITS (KG) AT VARIOUS COLD INFLATION PRESSURES (kPa)																
		Inflation (kPa)	40	50	60	70	80	90	100	120	140	160	180	200	240	280	320	360
		Inflation (bar)	0.4	0.5	0.6	0.7	0.8	0.9	1.0	1.2	1.4	1.6	1.8	2.0	2.4	2.8	3.2	3.6
320/85R34	Load Index																146	
	Single (KG)	NR	NR	800	850	925	1000	1060	1180	1285	1400	1500	1600	1700	1850	2000		
	Dual (KG)	570	620	700	750	810	880	930	1040	1130	1230	1320	1410	1500	1630	1760		
	Triple (KG)	530	580	660	700	760	820	870	970	1050	1150	1230	1310	1390	1520	1640		
380/85R46	Load Index																146	
	Single (KG)	NR	NR	1180	1250	1360	1450	1600	1800	2000	2180	2300	2360	2500	2800	3000		
	Dual (KG)	880	960	1040	1100	1200	1280	1410	1580	1760	1920	2020	2080	2200	2460	2640		
	Triple (KG)	820	890	970	1030	1120	1190	1310	1480	1640	1790	1890	1940	2050	2300	2460		

LOAD & INFLATION TABLE

Diagonal (Bias) Ply Tires

Agricultural Tractor Drive Wheel Tires Used As Singles

Used in Field Service and Speeds Up To 25 MPH

BASIC TIRE LOAD VALUES FOR TIRE SELECTION

Maximum Speed - 25 MPH

Tire Size	TIRE LOAD LIMITS (LBS.) AT VARIOUS COLD INFLATION PRESSURES (PSI)											
	12	14	16	18	20	22	24	26	28	30	32	
8.3-16	640	715	760	825	880	935(4)	965	1020	1070	1100	1140	1200@34(6)
8.3-24	880	965	1020	1100	1170	1230(4)						
9.5-16	825	910	965	1050	1100(4)	1170	1230	1280	1360	1390(6)		
9.5-24	1100	1200	1280	1390	1480(4)	1570	1650	1710	1820	1870(6)		
11.2-24	1320	1430	1570	1650(4)	1760	1870	1980	2090(6)				
11.2-28	1390	1520	1650	1760(4)								
11.2-36	1570	1760	1870	2040(4)								
11.2-38	1650	1760	1930	2090(4)								
12.4-16	1200	1320	1430	1520	1650	1710	1820	1930	1980	2090	2150(8)	2760@48(12)
12.4-24	1570	1710	1870(4)	1980	2150	2270	2400(6)	2470	2600	2680	2830(8)	
12.4-28	1710	1870	1980(4)									
12.4-38	1980	2150	2340(4)	2470	2600	2760	2910(6)					
12.4-42	2040	2270	2470(4)	2600	2760	2910	3080(6)					
13.6-24	*1870	2040(4)	2200	2340	2540	2680(6)	2830	2910	3080(8)			
13.6-28	*1980	2200(4)	2340	2540	2680	2830(6)	3000	3080	3300(8)	3420	3520	3740@36(10)
13.6-38	*2340	2540(4)	2760	2910	3080	3300(6)						
14.9-24	*2200	2400	2600	2830	3000(6)	3200	3300	3520(8)	3640	3740	3960	4400@38(12)
14.9-26	*2270	2540	2680	2910	3080(6)	3300	3420	3640	3740	3960	4080(10)	
14.9-28	*2340	2600	2830	3000	3200(6)	3420	3520	3740(8)	3860	4080	4180(10)	
14.9-30	*2470	2680	2910	3080	3300(6)	3520	3640	3860(8)	3960	4180	4300(10)	
14.9-38	*2760	3000	3300	3520	3740(6)							
15.5-38	*2600	2830	3080	3300	3520(6)							
16.9-24	*2680	*2910	3200	3420(6)	3640	3860	4080(8)	4300	4400(10)			
16.9-26	*2760	*3080	3300	3520(6)	3740	3960	4180	4400	4540(10)			
16.9-28	*2910	*3200	3420	3640(6)	3860	4080	4300(8)	4540	4680(10)			
16.9-30	*3000	*3300	3520	3740(6)	3960	4180	4400(8)	4680	4940(10)			
16.9-34	*3200	*3420	3740	3960(6)	4300	4540	4680(8)	4940	5200(10)			
16.9-38	*3300	*3640	3960	4180(6)	4540	4800	4940(8)					
18.4-16.1	*2150	*2340	2540(6)	2680	2910(8)							
18.4-24	*3200	*3520	3860(6)	4080	4400(8)	4540	4800	5080(10)	5360	5520	5680(12)	
18.4-26	*3300	*3640	3960(6)	4180	4540	4800	4940	5200(10)				
18.4-28	*3420	*3740	4080(6)	4400	4680(8)	4940	5200	5360(10)	5680	5840	6150(12)	
18.4-30	*3520	*3860	4180(6)	4540	4800(8)	5080	5360	5520(10)				
18.4-34	*3740	*4180	4400(6)	4800	5080(8)							
18.4-38	*3960	*4400	4680(6)	5080	5360(8)	5680	6000	6400(10)	6600	6800	7150(12)	
18.4-42	*4180	*4680	4940	5360	5680(8)	6000	6400	6600(10)				
20.8-34	*4540	*4940	5360	5840(8)	6150	6600(10)						
20.8-38	*4800	*5360	5680	6150(8)	6600	6950(10)	7150	7600	7850	8250	8550(14)	
20.8-42	*5080	*5520	6000	6400	6950	7400(10)						
23.1-26	*4800	*5200	5680(8)	6000	6400(10)	6800	7150(12)	7600	7600	7850(14)		
23.1-30	*5080	*5520	6000(8)	6400	6800(10)							
23.1-34	*5360	*5840	6400(8)	6800	7400(10)							
24.5-32	*5840	*6400	6800	7400	7850(10)	8250	8800(12)					

*Values at these inflation pressures are for determination of Dual Loads only. See Notes, Page 123.

LOAD & INFLATION TABLE

Diagonal (Bias) Ply Tires

Agricultural Tractor Drive Wheel Tires Used As Singles

Used in Field Service and Speeds Up To 25 MPH

BASIC TIRE LOAD VALUES FOR TIRE SELECTION

Maximum Speed - 25 MPH

Tire Size	TIRE LOAD LIMITS (LBS.) AT VARIOUS COLD INFLATION PRESSURES (PSI)										
	12	14	16	18	20	22	24	26	28	30	
17.5L-24	*2600	*2830	3080(6)	3300	3520	3640(8)	3860	4080	4180(10)		
19.5L-24	*3080	*3420	3640	3860	4180(8)	4400	4680(10)	4800	5080	5200(12)	
21L-24	*3640	*3960	4300	4540	4800	5080(10)	5360	5680	5840(12)	6150	6800@36(16)
28L-26	*5520	*6000	6600	6950(10)	7400(12)						
30.5L-32	*6950	*7600	8250(10)	8800	9350(12)	9900(14)	10500	11000(16)			

*Values at these inflation pressures are for determination of Dual Loads only.

NOTES 1. Figures in parentheses denote ply rating for which loads and inflations are maximum.

2. When used as duals, tire loads must be reduced. Multiply figures in above table by .88.

3. When used as triples, tire loads must be reduced. Multiply figures in above table by .82.

4. For shipping purposes, tire inflation pressures may be increased to 30 psi (consult tire manufacturer for minimum tire shipping pressure). Inflation pressure must be reduced to operating inflation before the tractor is removed from the carrier.

5. For R-3 tires used in free rolling service at speeds up to 10 MPH maximum, above loads may be increased 50% with a 4 psi increase in inflation pressure.

6. For R-4 tires in transport service, see Load & Inflation Table Agricultural R-4 Drive Wheel Tires Used on Industrial Tractors.

7. For above tires used in cyclic loading service (excluding hillside combines) without sustained high torque with speeds up to 5 MPH, above loads may be increased 87% (with 30% psi increase in inflation pressure). This load increase is also applicable to tires used on vehicles with mechanism capable of maintaining tires and wheels in a vertical position on slopes up to 11 (20% grade). Due to higher pressure specified for these tires, the rim and wheel manufacturers must be consulted.

8. For FIELD SERVICE at high torque (i.e. tillage), basic tire loads in the above table may be increased 11% ONLY IF THE TRACTOR TRANSPORT SPEED CAPABILITY IS 20 MPH OR LESS.

9. For R-1, R-2 and R-3 tires in transport service and operations which do not require sustained high torque, the following load limits at various speeds apply:

MAXIMUM SPEED	% CHANGE IN LOADS	CHANGE IN PRESSURE
10 MPH	+33% (except Hillside Combines)	None
15 MPH	+22% (except Hillside Combines)	None
20 MPH	+11% (except Hillside Combines)	None
25 MPH	SAME AS ABOVE TABLE	None

LOAD & INFLATION TABLE

Diagonal (Bias) Ply

Agricultural Tractor Drive Wheel Tires Used As Duals

Used in Field Service and Speeds Up To 25 MPH

(TIRE MUST ALSO MEET TIRE PTO HORSEPOWER CAPACITY, SEE TABLE OF CONTENTS)

Maximum Speed - 25 MPH

Tire Size	TIRE LOAD LIMITS (LBS.) AT VARIOUS COLD INFLATION PRESSURES (PSI)										
	12	14	16	18	20	22	24	26	28	30	32
18.4-34	3290	3680	3870 (6)	4220	4470 (8)						
18.4-38	3480	3870	4120 (6)	4470	4720 (8)	5000	5280	5630 (10)	5810	5980	6290 (12)
18.4-42	3680	4120	4350	4720	5000 (8)	5280	5630	5810 (10)			
20.8-34	4000	4350	4720	5140 (8)	5410	5810 (10)					
20.8-38	4220	4720	5000	5410 (8)	5810	6120 (10)	6290	6690	6910	7260	7520 (14)
20.8-42	4470	4860	5280	5630	6120	6510 (10)					
23.1-26	4220	4580	5000 (8)	5280	5630 (10)	5980	6290 (12)				
23.1-30	4470	4860	5280 (8)	5630	5980 (10)						
23.1-34	4720	5140	5630 (8)	5980	6510 (10)						
24.5-32	5140	5630	5980	6510	6910 (10)	7260	7740 (12)				
28L-26	4860	5280	5810	6120 (10)	6510 (12)						
30.5L-32	6120	6690	7260 (10)	7740	8230 (12)	8710 (14)					

NOTES: 1. Figures in parentheses denote ply rating for which loads and inflations are maximum.

2. For shipping purposes, tire inflation pressure may be increased to 30 psi. Inflation pressure must be reduced to operation inflation before the tractor is removed from the carrier.

3. For above tires used in cyclic loading service (excluding hillside combines) without sustained high torque with speeds up to 5 MPH, above loads may be increased 87% (with 30% psi increase in inflation pressure). This load increase is also applicable to tires used on vehicles with mechanism capable of maintaining tires and wheels in a vertical position on slopes up to 11 (20% grade). Due to higher pressure specified for these tires, the rim and wheel manufacturers must be consulted.

4. For R-1, R-2 and R-3 tires in transport service and operations which do not require sustained high torque, the following load limits at various speeds apply:

MAXIMUM SPEED	% CHANGE IN LOADS IN ABOVE TABLE	CHANGE IN INFL. PRESS
10 MPH	+33% (except Hillside Combines)	None
15 MPH	+22% (except Hillside Combines)	None
20 MPH	+11% (except Hillside Combines)	None
25 MPH	SAME AS ABOVE TABLE	None

LOAD & INFLATION TABLE

Radial Ply

Agricultural R-4 Drive Wheel Tires Used On Industrial Tractors

Tires Used As Singles With No Sustained High Torque

Tire Size	TIRE LOAD LIMITS (LBS.) AT VARIOUS COLD INFLATION PRESSURES (PSI)								
	25 MPH		26	29	32	35	38	41	44
16.9R24	4300	4800	5200	5680	6150	6600	6950 (148 A8)	7400	7600 (151 A8)
16.9R28	4540	5080	5680	6150	6600	6950	7400 (150 A8)	7850	8250 (154 A8)
17.5LR24	4080	4540	5080	5520	5840	6150	6600 (146 A8)	6950	7400 (150 A8)
19.5LR24	4940	5520	6000	6600	6950	7400	7850 (152 A8)	8250	8800 (156 A8)

NOTE: 1. Bold face denotes maximum load for the Service Description (Load Index Speed Symbol) in parenthesis.
 2. Above loads and inflation pressures are for transport service @ speeds up to 25 MPH.
 3. For speeds not exceeding 5 MPH, above loads may be increased 25%.

Diagonal (Bias) Ply

Agricultural R-4 Drive Wheel Tires Used On Industrial Tractors

Tires Used As Singles With No Sustained High Torque

Tire Size	TIRE LOAD LIMITS (LBS.) AT VARIOUS COLD INFLATION PRESSURES (PSI)								
	18	20	22	24	26	28	30	32	
14.9-24	3520	3740	4080	4300 ⁶	4540	4800	5080 ⁸	5200	6400 ¹² @ 4 2
14.9-28	3740	4080	4300	4680 ⁶	4940	5080	5360 ⁸	5680	6150 ¹⁰ @ 3 6
16.9-24		4680	4940 ⁶	5200	5520	5840 ⁸	6150	6400 ¹⁰	
16.9-28		4940	5200 ⁶	5680	6000	6150 ⁸	6600	6800 ¹⁰	
18.4-24		5520 ⁶	5840	6400 ⁸	6600	6950	7400 ¹⁰	7600	8250 ¹² @ 3 6
18.4-28		5840 ⁶	6400	6800 ⁸	7150	7400	7850 ¹⁰	8250	8800 ¹² @ 3 6
17.5L-24		4400 ⁶	4680	5080	5360 ⁸	5520	5840	6150 ¹⁰	
19.5L-24		5200	5680	6000 ⁸	6400	6600 ¹⁰	6950	7400	7600 ¹² @ 3 4
21L-24		6150	6600 ⁸	6950	7400 ¹⁰	7850	8050	8550 ¹²	9900 ¹⁶ @ 4 0

NOTES: 1. The small index numbers denote ply rating for which the accompanying loads and inflations are maximum.
 2. Above loads and inflation pressures are for transport service @ speeds up to 25 MPH.
 3. For speeds not exceeding 5 MPH, above loads may be increased 25%.

Diagonal (Bias) Ply

Metric Drive Wheel Tires (Special Applications)

Tire Size	TIRE LOAD LIMITS (LBS.) AT VARIOUS COLD INFLATION PRESSURES (PSI)									
	Inflation (psi)	20	25	30	35	40	45	50	55	60
	Load Index						165 (12PR)			
380/95D38	15 MPH	7150	8050	9100	9900	10700	11400			
380/95D38	5 MPH	9010	10140	11470	12470	13480	14360			
	Load Index		169						186	
VA500/95D32	15 MPH	11000	12800	13900	15200	16500	17600	18700	19800	20900
VA500/95D32	5 MPH	13860	16130	17510	19150	20790	22180	23560	24950	26330

CYCLIC SERVICE LOAD & INFLATION TABLE

DIAGONAL (BIAS) PLY AGRICULTURAL DRIVE WHEEL TIRES
USED ON AGRICULTURAL HARVESTING EQUIPMENT IN CYCLIC
LOADING FIELD SERVICE AND ROAD TRANSPORT

(EXCLUDING HILLSIDE COMBINES)

TIRES USED AS SINGLES

Tire Size Designation	Ply Rating	Inflation Pressure		Field Service Max. Cyclic Load				Road Transport	
				Max. Speed 6 MPH		Max Speed 10 MPH		Max. Load (Max. Speed 25 MPH)	
		psi	kPa	lbs.	kg	lbs.	kg	lbs.	kg
14.9-24	6	26	180	5620	2540	5100	2310	3520	1600
	8	34	230	6600	3000	5980	2710	4080	1850
14.9-26	6	26	180	5760	2610	5240	2380	3640	1650
	10	42	290	7650	3480	6950	3160	4800	2180
16.9-26	6	24	170	6600	3000	5980	2710	4180	1900
	10	36	250	8500	3860	7700	3500	5360	2430
18.4-16.1	6	20	140	4740	2150	4320	1960	2910	1320
	8	26	180	5440	2470	4940	2240	3420	1550
18.4-26	6	20	140	7400	3360	6750	3060	4540	2060
	10	34	230	9700	4420	8850	4020	6150	2800
18.4-30	6	20	140	7800	3540	7100	3220	4800	2180
	8	26	180	9000	4080	8150	3700	5520	2500
	10	34	230	10300	4680	9400	4260	6600	3000
18.4-42	10	34	230	12300	5620	11200	5100	7850	3550
20.8-38	8	24	170	11500	5220	10500	4760	7150	3250
	10	28	190	13000	5900	11800	5360	7850	3550
	14	42	290	16000	7250	14500	6600	10200	4625
20.8-42	10	28	190	13800	6250	12600	5700	8250	3750
	14	42	290	17000	7700	15500	7050	10700	4875
23.1-26	10	26	180	12000	5440	10900	4940	7600	3450
	12	32	220	13400	6100	12200	5520	8550	3875
	14	36	250	14700	6650	13300	6050	9100	4125
24.5-32	10	26	180	14700	6650	13300	6050	9100	4125
	12	32	220	16500	7500	15000	6800	10200	4625
28L-26	10	24	170	13000	5900	11800	5360	8250	3750
	12	26	180	13800	6250	12600	5700	8800	4000
30.5L-32	12	26	180	17500	7950	15900	7250	11000	5000
	14	28	190	18500	8400	16800	7600	11400	5150
	16	34	230	20600	9350	18700	8500	12800	5800
30.5L-32VA	16	34	230	20600	9350	18700	8500	12800	5800

See notes on Page 127.

CYCLIC SERVICE LOAD & INFLATION TABLE

RADIAL PLY

AGRICULTURAL DRIVE WHEEL TIRES

USED ON AGRICULTURAL HARVESTING EQUIPMENT IN
CYCLIC LOADING FIELD SERVICE AND ROAD TRANSPORT

(EXCLUDING HILLSIDE COMBINES)

TIRES USED AS SINGLES

Tire Size Designation	Basic Tire Load Index	Inflation Pressure		Field Service Max. Cyclic Load				Road Transport Max. Load (Max. Speed 25 MPH)	
				Max. Speed 6 MPH		Max Speed 10 MPH			
		psi	kPa	lbs.	kg	lbs.	kg	lbs.	kg
16.9R26	135	30	210	8150	3700	7450	3380	5360	2430
18.4R26	140	30	210	9400	4260	8550	3880	6400	2900
18.4R38	141	24	160	9650	4380	8800	4000	6600	3000
	146	30	210	11200	5100	10200	4640	7600	3450
18.4R42	148	30	210	11800	5360	10800	4880	8050	3650
20.8R38	147	24	160	11600	5240	10500	4760	8050	3650
	153	30	210	13700	6200	12500	5660	9100	4125
20.8R42	155	30	210	14500	6600	13300	6000	9650	4375
380/90R46	149	41	280	12200	5540	11100	5040	7850	3550
420/80R46	149	35	240	12200	5540	11100	5040	7600	3450
480/70R28	151	52	360	12900	5860	11800	5340	8250	3750
650/75R32	167	41	280	20400	9250	18600	8450	12800	5800
	172	52	360	23600	10700	21500	9750	14800	6700
600/65R28	147	29	200	11600	5260	10500	4760	7850	3550
800/65R32	167	29	200	20400	9250	18600	8450	12800	5800
	172	41	280	23600	10700	21500	9750	15200	6900
900/60R32	176	44	300	26610	12070	23475	10650	17600	8000

- Notes:
1. For tires used in dual service, above tire load limits must be reduced. Multiply figures in the above table by 0.88.
 2. The load ratings in the above table reflect a different operating duty cycle when compared to agricultural tractors. This cyclic service is intended for use on a vehicle with a minimal requirement for torque transmission and with appreciable total weight fluctuations; e.g., combine grain tanks which are repeatedly filled and emptied. Unloading is to occur before off-field transport.
 3. The above road transport loads apply to all speeds up to and including 25 mph.
 4. Due to the higher inflation pressures specified for these tires, the tire and wheel manufacturers must be consulted.
 5. The above loads are also applicable to tires used on vehicles with mechanisms capable of maintaining tires and wheels in a vertical position on slopes up to an 11" (20% grade).

LOAD & INFLATION TABLE

High Flotation Tires Used In Agricultural, Logging And Off-the-Road Service

8

MAXIMUM SPEED 30 MPH

Tire Size	30 MPH TIRE LOAD LIMITS (LBS.) AT VARIOUS COLD INFLATION PRESSURES (PSI)										
	10	15	20	25	30	35	40	45	50	55	60
25x7.50-15NHS	505	640	760	855	965 ⁴	1050	1140	1230 ⁶	1280	1360	1430 ⁸
25x12.50-15NHS	550	695	825 ⁴	935	1050 ⁶						
27x8.50-15NHS	640	805 ²	965	1100	1230 ⁴	1320	1430	1570 ⁶			
27x9.50-15NHS	660	855	990	1140	1280 ⁴	1390	1480	1610 ⁶	1710	1820	1870 ⁸
27x10.50-15NHS	695	880	1020	1170	1320	1430	1520	1650 ⁶			
29x12.50-15NHS	880 ²	1140	1320 ⁴								
31x12.50-15NHS	1100	1430	1650 ⁴								
31x13.50-15NHS	1100	1390	1650 ⁴	1870	2090						
31x15.50-15NHS	1140 ²	1430	1710 ⁴	1930	2150 ⁶	2340	2540	2760 ⁸			
33x12.50-15NHS	1390	1760	2090 ⁴								
36x13.50-15NHS	1760	2200	2600 ⁴								
38x14.00-20NHS	1390	1760	2090	2340 ⁴							
38x18.00-20NHS	1430	1820	2150	2400	2680	3000 ⁸					
38x20.00-16.1NHS	2090	2680	3200 ⁴	3640	3960 ⁶	4400 ⁸	4800	5080 ¹⁰			
41x14.00-20NHS	1820	2340	2760	3080 ⁴							
42x25.00-20NHS	1980	2540	3000	3420	3740 ⁸	4180 ¹⁰	4400	4800 ¹²			
44x18.00-20NHS	2270	2830	3420 ⁴								
44x41.00-20NHS	2680	3420	3960	4540 ¹⁰							
48x20.00-24NHS	2540	3200	3740	4300	4800	5200 ⁸					
48x25.00-20NHS	3000	3740	4400 ⁶	5080	5680 ⁸	6150 ¹⁰	6600	7150	7600 ¹⁴		
48x31.00-20NHS	3080	3960	4680 ⁶	5360 ⁸	5840 ¹⁰	6400	6950 ¹²	7400 ¹⁴			
54x31.00-26NHS	3520	4540	5360 ⁶	6150 ⁸	6800 ¹⁰						
66x43.00-25NHS	5840	7400 ⁶	8800 ⁸	9900 ¹⁰	11000 ¹²						
66x44.00-25NHS	6000	7600 ⁶	9100	10200 ¹⁰	11400	12800	13600 ¹⁶				
67x34.00-25NHS	5840	7400	8800	10200 ⁸	11400 ¹⁰	12300 ¹²	13200 ¹⁴				
67x34.00-26NHS	5840	7400	8800	9900 ⁸	11000 ¹⁰	12000 ¹²	13200 ¹⁴				
67x34.00-30NHS	5200	6600	7850	8800 ⁸	9900 ¹⁰	11000 ¹²					
68x50.00-32NHS	5840	7400	8800 ⁸	9900 ¹²	11000	12300 ¹⁶					
VA73x44.00-32	6800	8550	10200	11700	12800 ¹²	14300	15200 ¹⁶				

NOTES: 1: The small index numbers denote ply rating for which accompanying loads and inflations are maximum.

2 For operations at other speeds with no change in inflation pressure, the loads in the above table may be changed as follows:

MAXIMUM SPEED (mph)	% CHANGE IN LOADS
20	+12
10	+32
5	+58
* CREEP	+100
STATIONARY	+165

* Creep speed is a travel rate of not over 200 feet in a 30 minute period.

3 For variable loading operations where loads increase or decrease, the load per tire when the vehicle is empty must be less than 40 percent of the load on the tire when the vehicle is fully loaded. Maximum load may not be carried for more than one mile before unloading operation starts. Loading or unloading must be completed within one mile. The following factors apply to the loads and inflation pressures in the above load & inflation table:

MAXIMUM SPEED (mph)	% CHANGE IN LOADS	CHANGE IN (COLD) INFL. PRESSURE (PSI)
20	+50	+5
15	+70	+5
10	+85	+5
6	+100	+5

TERRA-TIRE^{fi} SPECIAL SERVICE LOAD & INFLATION TABLE

Max distance 10 Miles*

Operation Transport Over Maintained Surface*

MAXIMUM SPEED 30 MPH* LOADS (lbs.) AT VARIOUS INFLATION PRESSURES (psi-cold)

Tire Size	15	20	25	30	35	40	45	50	55
66x43.00-25 NHS	7605	9640 ⁶	11410 ⁸	13660 ¹⁰	15200 ¹²	16630	17980	19260	20480 ²⁰
66x44.00-25NHS	7850	9950 ⁶	11780	14100	15690	17160	18560 ¹⁶		
67x34.00-25 NHS	7670	9740	11530 ⁸	13810 ¹⁰					

(Pressures Have Been Increased 5 psi Over Rated)

*CAUTION Tire failure could occur if recommended is exceeded.

LOGGING SERVICE

UP TO 10 MPH LOADS (lbs.) AT VARIOUS INFLATION PRESSURES (psi-cold)

Tire Size	10	15	20	25	30	35	40	45	50	55
42x25.00-20 NHS	2625	3330	3940	4490	4995	5465	5910 ¹²			
66x43.00-25 NHS	7800	9885	11700	13330	14830 ¹²					
67x34.00-25NHS	7885	9995	11830	13480 ¹⁰						
73x44.00-32 NHS	9090	11520	13635	15535	17285	18915	20450 ¹⁶			

SEE FLANGE RECOMMENDATION PAGE 151.

LOAD & INFLATION TABLE

Garden Tractor Tires Maximum Speed 20 Miles Per Hour

Tire Size	MAX. SPEED 20 MPH TIRE LOAD LIMITS (LBS.) AT VARIOUS COLD INFLATION PRESSURES (PSI)																
	psi	6	8	10	12	14	16	18	20	22	24	26	28	30	32	34	36
5-12	lbs.	175	210	240	265	290	310 ²	340	355	375	395	420	440	455	465	495 ⁴	
6-12	lbs.	240	290	330	365	395 ²	430	455	495	520	550	565	600 ⁴				
6-14	lbs.	265	320	365	410	440	480	505	550	565	600	640	660 ⁴				
6-16	lbs.	300	355	395	440	480	520	565	600	640	660	695	740 ⁴				
7-12	lbs.	320	375	420	480 ²	520	565	600	640	675	715 ⁴						
7-14	lbs.	355	410	465	520	565	615	660	715	740	785 ⁴	825	855	910	935	965	990 ⁶
7-16	lbs.	385	455	520	585 ²	640	675	740	785	825	855	910	935	990	1020	1050	1100 ⁶
8-16	lbs.	565	660	760 ²	825	910	990	1070 ⁴	1140	1200	1230	1320	1360 ⁶				

FARM IMPLEMENT (FI) TIRES FOR HIGHWAY AND AGRICULTURAL SERVICE

Note: This Load & Inflation Table for FI-Tires only.

See Page 132 for Bias Ply Implement Load & Inflation Table.

Tire Size		TIRE LOAD LIMITS (LBS.) AT VARIOUS COLD INFLATION PRESSURES (PSI)														
		20	25	30	35	40	45	50	55	60	65	70	75	80	85	90
9.5L-15FI	Intermittent Highway Service	1410	1600	1780(B)	1950	2110	2260(C)	2400	2540	2670(D)						
	30 MPH	1690	1920	2140(B)	2340	2530	2710(C)	2880	3050	3200(D)						
10.00-15FI	Intermittent Highway Service	2080	2370	2640(B)	2890	3120	3350(C)	3560	3760	3960(D)						
	30 MPH	2500	2840	3170(B)	3470	3740	4020(C)	4270	4510	4750(D)						
11L-15FI	Intermittent Highway Service	1640	1870	2080(B)	2280	2470	2640(C)	2810	2970	3120(D)	3270	3420	3560(E)	3700	3830	3960(F)
	30 MPH	1970	2240	2500(B)	2740	2960	3170(C)	3370	3560	3740(D)	3920	4100	4270(E)	4440	4600	4750(F)
12.5L-15FI	Intermittent Highway Service	1940	2210	2460(B)	2690	2910	3120(C)	3320	3510	3690(D)	3870	4040	4210(E)	4370	4520	4680(F)
	30 MPH	2330	2650	2950(B)	3230	3490	3740(C)	3980	4210	4430(D)	4640	4850	5050(E)	5240	5420	5620(F)
12.5L-16FI	Intermittent Highway Service	2020	2300	2560(B)	2800	3030	3250(C)	3450	3650	3840(D)	4020	4200	4380(E)	4540	4710	4870(F)
	30 MPH	2420	2760	3070(B)	3360	3640	3900(C)	4140	4380	4610(D)	4820	5040	5260(E)	5450	5650	5840(F)
14L-16.1FI	Intermittent Highway Service	2670	3040	3390(C)												
	30 MPH	3200	3650	4070(C)												
16.5L-16.1FI	Intermittent Highway Service	3390	3860	4300(C)	4700	5080	5450(D)	5790	6130	6450(E)						
	30 MPH	4070	4630	5160(C)	5640	6100	6540(D)	6950	7360	7740(E)						
21.5L-16.1FI	Intermittent Highway Service	5070	5770	6420(D)	7030	7600	8140(E)									
	30 MPH	6080	6920	7700(D)	8440	9120	9770(E)									

Diagonal (Bias) Ply Tires Used For Skid-Steer/Mini-Loader Service Maximum Speed - 5 MPH

Tire Size	TIRE LOAD LIMITS (LBS.) AT VARIOUS COLD INFLATION PRESSURES (PSI)												
	20	25	30	35	40	45	50	55	60	65	70	75	80
10-16.5NHS			2760(4)	3020	3260	3500(6)	3720	3930	4140(8)				
12-16.5NHS 6330(12)			3560	3900	4220(6)	4520	4810(8)	5080	5350	5600(10)	5850	6090	
14-17.5NHS			4820(6)	5270	5700(8)	6110	6490	6870(10)					
15-19.5NHS			6130(6)	6710	7250(8)	7770	8260(10)	8740	9190(12)				

NOTES 1. Figures in parentheses denote ply rating for which loads and inflations are maximum.
2. For 10 MPH service, the above loads must be reduced 21% at the same inflation pressures.

LOAD & INFLATION TABLE

Diagonal Bias Ply

Agricultural Tractor Steering Wheel Tires Used In Field Service

Including Hillside Combines Tires Used As Singles

MAXIMUM SPEED 25 MPH

Tire Size	TIRE LOAD LIMITS (LBS.) AT VARIOUS COLD INFLATION PRESSURES (PSI)											
	24	28	32	36	40	44	48	52	56	60	64	68
4.00-12 SL	300	330	365	395	420	440	465	495 ⁴				
4.00-15 SL	355	395	430	465	495	535	565	585 ⁴				
4.00-19 SL	420	480	520	565	600	640	675	715 ⁴				
5.00-15 SL	480	535	585	640	675	715 ⁴						
5.50-16 SL	600	660	715	785	855 ⁴	910	935	990	1050 ⁶			
6.00-14 SL	615	695	740	805	880	935	965	1020 ⁶				
6.00-16 SL	675	760	825	910 ⁴	965	1020	1070	1140 ⁶	1200	1230	1280	1360 ⁸
6.50-16 SL	785	855	935	1020 ⁴	1100	1140	1230 ⁶					
7.50-16 SL	990	1100	1200	1320	1390	1480 ⁶	1570	1650	1710 ⁸			
7.50-18 SL	1070	1200	1320	1430	1520	1610 ⁶						
7.50-20 SL	1170	1280	1390 ⁴	1520	1610	1710 ⁶						
8.00-16 SL	1070	1200	1320	1430	1520 ⁶	1610	1710	1820	1870	1980	2040 ¹⁰	
9.50-20 SL	1650	1870	2040	2200	2340	2470 ⁸						
10.00-16 SL	1570	1760	1930 ⁶	2090	2200	2340 ⁸						
11.00-16 SL	1870	2090	2270 ⁶	2470	2600 ⁸	2760	2910	3080	3300	3420 ¹²		
11.00-24 SL	2400	2680	2910	3200	3420 ⁸	3640	3860 ¹⁰					

LOW SECTION HEIGHT

7.5L-15 SL	965	1070	1170	1280	1360	1430 ⁶						
9.5L-15 SL	1170	1280	1430	1520 ⁶	1650	1760	1870 ⁸					
11L-15 SL	1390	1570	1710 ⁶	1870	1980	2090 ⁸	2200	2340 ¹⁰				
11L-16 SL	1480	1650	1760 ⁶	1930	2090	2200 ⁸	2340	2470 ¹⁰	2540	2680	2760 ¹²	
14L-16.1 SL	2270	2540 ⁶	2830	3000 ⁸	3200	3420 ¹⁰						
16.5L-16.1 SL	2910	3200	3520 ⁸	3860	4080 ¹⁰							
14.5/75-16.1 SL	2270	2540	2760	3000	3200 ¹⁰							

- NOTES: 1. The small index numbers denote ply rating for which the accompanying loads are maximum.
 2. Maximum shipping pressures are the maximum inflation pressures for the tire sizes and ply ratings shown.
 3. For above tires used in cyclic loading service (excluding hillside combines) with speeds up to 5 MPH, above loads may be increased 67%. This load increase is also applicable to tires used on vehicles with mechanism capable of maintaining tires and wheels in a vertical position on slopes up to 11 (20% grade).
 4. Tire Load limits at various speeds with no change in pressure:

MAX. SPEED	% INCREASE TO LOADS IN ABOVE TABLE
10 MPH	+50% (except Hillside Combines)
15 MPH	+28% (except Hillside Combines)
20 MPH	+11 %
25 MPH	SAME AS ABOVE TABLE

LOAD & INFLATION TABLE

Bias Ply Implement Tires

MAXIMUM TIRE LOAD RATINGS FOR SPEEDS 30 MPH AND UNDER

Tire Size Designation	TIRE LOAD LIMITS (LBS.) AT VARIOUS COLD INFLATION PRESSURES (PSI)										
	24	28	32	36	40	44	48	52	56	60	64
4.00-9 SL	365	410	440	480	520	550(4)					
4.00-12 SL	440	495	535	585	640	675(4)					
4.00-15 SL	535	585	640	695	740	785(4)					
4.00-18 SL	585(2)	660	715	785	825	880(4)					
5.00-15 SL	715	805	880	965(4)							
5.50-16 SL	910	990	1100	1170(4)							
5.90-15 SL	855	935	1050	1140(4)							
6.00-16 SL	1020	1140	1230(4)	1360	1430	1520(6)					
6.40-15 SL	965	1070	1170(4)	1280	1360	1430	1520(6)				
6.50-16 SL	1140	1280	1390	1520	1610	1710(6)					
6.70-15 SL	1070	1170	1280(4)	1390	1520	1610(6)					
7.50-10 SL	1100	1230	1360	1480(6)							
7.50-14 SL	1230	1360(4)									
7.50-16 SL	1480	1650(4)	1820	1930	2090	2200	2340	2470	2600	2680(10)	
7.50-18 SL	1520	1710	1870	2040(6)							
7.50-20 SL	1610	1760(4)	1930	2090(6)							
7.50-24 SL	1650	1870(4)									
7.60-15 SL	1230	1390(4)	1520	1650	1760(6)	1870	1980	2090(8)			
9.00-10 SL	1480(4)	1650	1820	1980	2090	2200	2340	2470(10)			
9.00-16 SL	1980	2200	2400	2600	2760	2910(8)	3080	3300(10)			
9.00-24 SL	2540	2830(6)	3080	3300	3520(8)						
10.00-15 SL	2270	2540	2760	3000	3200(8)						
11.25-24 SL	3300	3640	4080(8)								
11.25-28 SL	3420	3860	4180	4540	4800	5080	5360(12)				
13.50-16.1 SL	3520(6)	3860	4300(8)								

Low Section Height Tires											
8.5L-14 SL	1390	1570	1710	1870(6)							
9.5L-14 SL	1570(4)	1760	1930(6)	2090	2200	2400(8)					
9.5L-15 SL	1650	1820	2040(6)	2200	2340	2470(8)					
11L-14 SL	1870	2040(6)									
11L-15 SL	1930	2150(6)	2340	2540(8)	2760	2910(10)	3080	3200(12)			
11L-16 SL	2040	2270(6)	2470	2680(8)	2830	3000(10)					
12.5L-15 SL	2270	2540(6)	2760	3000(8)	3200	3420(10)	3640	3860(12)			
12.5L-16 SL	2400	2680	2910	3080(8)	3300	3520	3740	3960(12)	4180(14)		
14L-16.1 SL	3200(6)										
16.5L-16.1 SL	3960(6)	4400(8)	4800	5200(10)							
19L-16.1 SL	4940	5520	6000(10)								
21.5L-16.1 SL	6000(8)	6600(10)	7150(12)	7850(14)							

- NOTES: 1. Figures in parentheses denote ply rating for which bold face loads and inflations are maximum.
 2. Maximum shipping pressures are the maximum inflation pressures for the tire sizes and ply ratings shown.
 3. For speeds not exceeding 10 MPH, above loads may be increased 15%.

HORSEPOWER CAPABILITIES OF DRIVE TIRES USED ON TWO WHEEL DRIVE AND FRONT AXLE ASSIST TRACTORS AT VARIOUS SPEEDS

Take time to carefully match the recommended tire size to your power unit and field operating speed to obtain maximum efficiency and tire life.

Tractor manufacturers recommend operation of their equipment at field speeds of 5 mph and above. Tire sizes fitted to most tractors are selected assuming field operation in this speed range. If speed is reduced below this recommended range for prolonged time periods, tire and/or equipment problems can be expected.

Excessive tire wear, slippage, and excessive fuel consumption are problems that may be encountered when a tire's horsepower capacity is exceeded. These problems may be eliminated by careful evaluation of your equipment's horsepower capabilities, drive tire loads and inflation pressure, and the speed at which you operate your equipment. Increasing or decreasing your continuous operating speed by small increments in the critical field speed range will make a significant change in tire requirements, tire performance, and in overall efficiency and performance of your equipment.

The following tables (next few pages) provide you with an easy way to be sure that you have the right size tires for your operation. As this table shows, field tillage speeds less than the recommended 5 MPH may require a larger tire size. It also may help you to determine whether singles, duals, or triples should be used. Since the horsepower capability of a tire depends on the inflation pressure in the tire, the table below shows horsepower ratings for radial tires at a range of pressures from 6 PSI up to rated pressure. Bias tires cannot be used below 12 PSI, so only 12 PSI and above are shown for them. Four-wheel drive (all tires same size) tractors are not shown because current size selection criteria result in adequate tire horsepower capability.

TO USE THIS TABLE: Find the size of interest in the left-hand column and select the operating pressure determined by load considerations*. Follow that row across to the right until you come to the type of tractor and tillage speed that you use. For front wheel assist tractors, horsepower capacity is based on rear drive tire size and inflation. The number shown in the table is the maximum PTO horsepower the tires can transmit when duals (four tires per axle) are used on the tractor. To obtain the horsepower ratings for singles (two tires per axle) and triples (six tires per axle), multiply the horsepower ratings by 0.568 and 1.397 respectively. Please note that tillage speeds below 5 MPH are not recommended by tractor manufacturers. The reference horsepower in the table must be greater than your tractor PTO horsepower. If the tractor PTO horsepower exceeds the amount shown in the table then you must either use a tire with a higher horsepower capacity or else decrease the drawbar pull requirements to enable a higher tillage speed. NOTE: The higher the operating speed, the more horsepower a tire can handle.

*See section titled How To Use This Handbook .

HORSEPOWER CAPACITIES AS DUALS

Main Drive Tire Size	Load Indicator/ Ply Rating	Inflation Pressure (PSI)	RECOMMENDED 5 MPH		3 MPH	
			2 WD	Front Assist	2 WD	Front Assist
14.9R46		6	118	139	71	84
14.9R46		12	178	210	107	126
14.9R46	H	18	224	264	135	158
14.9R46	H H	24	265	312	159	187
14.9R46	H H H	30	305	358	183	215
15.5-38		12	136	160	81	96
15.5-38	6	20	184	216	110	130
15.5R38		6	101	118	60	71
15.5R38		12	152	179	91	107
15.5R38	H	18	190	223	114	134
16.9-38		12	172	202	103	121
16.9-38	6	18	218	256	131	154
16.9-38	8	24	258	303	155	182
16.9R38		6	129	152	77	91
16.9R38		12	195	229	117	138
16.9R38	H	18	244	287	146	172
16.9R38	H H	24	296	348	178	209
16.9R38	141	24	296	348	178	209
16.9R38	H H H	30	334	393	200	236
18.4-34		12	195	229	117	138
18.4-34	6	16	229	270	138	162
18.4-34	8	20	265	312	159	187
18.4-34	12	32	344	405	207	243
18.4R34		6	148	174	89	104
18.4R34		12	218	256	131	154
18.4R34	H	18	280	329	168	197
18.4R34	H H	24	321	377	192	226
18.4R34	144	24	321	377	192	226
18.4-38		12	207	243	124	146
18.4-38	6	16	244	287	146	172
18.4-38	8	20	280	329	168	197
18.4-38	10	26	334	393	200	236
18.4-38	12	32	373	439	224	263
18.4R38		6	156	184	94	110
18.4R38		12	229	270	138	162
18.4R38	H	18	296	348	178	209
18.4R38	H H	24	344	405	207	243
18.4R38	146	24	344	405	207	243
18.4-42		12	218	256	131	154
18.4-42	8	20	296	348	178	209
18.4-42	10	26	344	405	207	243
18.4R42		6	161	189	96	113
18.4R42		12	244	287	146	172
18.4R42	H	18	313	368	188	221
18.4R42	H H	24	362	426	217	256
18.4R42	148	24	362	426	217	256

Note: For single tires, multiply the above horsepower rating by 0.568. For triples, multiply the above horsepower

HORSEPOWER CAPACITIES AS DUALS

Main Drive Tire Size	Load Indicator/ Ply Rating	Inflation Pressure (PSI)	RECOMMENDED 5 MPH		3 MPH	
			2 WD	Front Assist	2 WD	Front Assist
18.4R46		6	172	202	103	121
18.4R46		12	258	303	155	182
18.4R46	H	18	321	377	192	226
18.4R46	H H	24	386	454	232	272
18.4R46	H H H	30	446	525	268	315
20.8-34		12	237	279	142	167
20.8-34	8	18	305	358	183	215
20.8-34	10	22	344	405	207	243
20.8-34	14	32	420	494	252	296
20.8R34		6	178	210	107	126
20.8R34		12	265	312	159	187
20.8R34	H	18	334	393	200	236
20.8-38		12	250	294	150	177
20.8-38	8	18	321	377	192	226
20.8-38	10	22	362	426	217	256
20.8-38	14	32	446	525	268	315
20.8R38		6	190	223	114	134
20.8R38		12	280	329	168	197
20.8R38	H	18	355	417	213	250
20.8R38	H H	24	420	494	252	296
20.8R38	153	24	420	494	252	296
20.8-42		12	265	312	159	187
20.8-42	10	22	386	454	232	272
20.8R42		6	195	229	117	138
20.8R42		12	296	348	178	209
20.8R42	H	18	373	439	224	263
20.8R42	H H	24	446	525	268	315
20.8R42	155	24	446	525	268	315
23.1-34		12	280	329	168	197
23.1-34	8	16	334	393	200	236
23.1-34	10	20	386	454	232	272
24.5-32		12	305	358	183	215
24.5-32	10	20	409	482	246	289
24.5-32	12	24	459	540	275	324
24.5-32	16	30	516	607	310	364
24.5R32		6	224	264	135	158
24.5R32		12	334	393	200	236
24.5R32	H	18	430	506	258	304
24.5R32	H H	24	503	592	302	355
30.5L-32		12	362	426	217	256
30.5L-32	10	16	430	506	258	304
30.5L-32	12	20	488	574	293	344
30.5L-32	14	22	516	607	310	364
30.5L-32	16	26	574	675	344	405

Note: For single tires, multiply the above horsepower rating by 0.568. For triples, multiply the above horsepower

HORSEPOWER CAPACITIES AS DUALS

Main Drive Tire Size	Load Indicator/ Ply Rating	Inflation Pressure (PSI)	RECOMMENDED 5 MPH		3 MPH	
			2 WD	Front Assist	2 WD	Front Assist
30.5L-32VA	16	26	574	675	344	405
30.5L-32VA	24	38	709	834	426	501
30.5LR32		6	265	312	159	187
30.5LR32		12	396	466	238	280
30.5LR32	H	18	503	592	302	355
250/95R50		6	86	101	52	61
250/95R50		12	122	144	73	86
250/95R50		17	156	184	94	110
250/95R50	125	23	190	223	114	134
250/95R50	128	29	207	243	124	146
250/95R50	131	35	224	264	135	158
250/95R50	137	46	265	312	159	187
250/95R54		6	89	105	54	63
250/95R54		12	125	147	75	88
250/95R54		17	161	189	96	113
250/95R54		23	201	237	121	142
250/95R54		29	218	256	131	154
250/95R54		35	229	270	138	162
250/95R54		46	271	319	163	191
250/95R54	141	52	296	348	178	209
320/85R34		6	92	108	55	65
320/85R34		12	129	152	77	91
320/85R34	121	17	167	196	100	118
320/85R34	127	23	201	237	121	142
320/85R34	131	29	224	264	135	158
320/85R34	133	35	237	279	142	167
320/85R38		6	98	115	59	69
320/85R38		12	136	160	81	96
320/85R38		17	178	210	107	126
320/85R38		23	213	250	128	150
320/85R38		29	237	279	142	167
320/85R38	135	35	250	294	150	177
320/85R38		46	296	348	178	209
320/85R38	143	52	313	368	188	221
320/80R42		6	98	115	59	69
320/80R42		12	136	160	81	96
320/80R42	123	17	178	210	107	126
320/80R42	130	23	218	256	131	154
320/80R42	133	29	237	279	142	167
320/80R42		35	250	294	150	177
320/80R42	141	46	296	348	178	209
320/90R42		6	109	128	65	77
320/90R42		12	152	179	91	107
320/90R42	126	17	195	229	117	138
320/90R42		23	237	279	142	167
320/90R42		29	258	303	155	182

Note: For single tires, multiply the above horsepower rating by 0.568. For triples, multiply the above horsepower

HORSEPOWER CAPACITIES AS DUALS

Main Drive Tire Size	Load Indicator/ Ply Rating	Inflation Pressure (PSI)	RECOMMENDED 5 MPH		3 MPH	
			2 WD	Front Assist	2 WD	Front Assist
320/90R42	139	35	280	329	168	197
320/90R46		6	112	132	67	79
320/90R46		12	156	184	94	110
320/90R46	127	17	201	237	121	142
320/90R46	135	23	250	294	150	177
320/90R46	138	29	271	319	163	191
320/90R46	140	35	288	339	173	203
320/90R46	146	46	344	405	207	243
320/90R46	148	52	362	426	217	256
320/90R50		6	118	139	71	84
320/90R50		12	167	196	100	118
320/90R50	129	17	213	250	128	150
320/90R50	136	23	258	303	155	182
320/90R50	140	29	288	339	173	203
320/90R50	142	35	305	358	183	215
320/90R50	148	46	362	426	217	256
320/90R54		6	122	144	73	86
320/90R54		12	172	202	103	121
320/90R54		17	224	264	135	158
320/90R54	138	23	271	319	163	191
320/90R54		29	296	348	178	209
320/90R54		35	313	368	188	221
320/90R54	149	46	373	439	224	263
340/85R46		6	118	139	71	84
340/85R46		12	167	196	100	118
340/85R46	129	17	213	250	128	150
340/85R46		23	258	303	155	182
340/85R46	140	29	288	339	173	203
380/80R38		6	118	139	71	84
380/80R38		12	167	196	100	118
380/80R38	130	17	218	256	131	154
380/80R38	137	23	265	312	159	187
380/80R38	140	29	288	339	173	203
380/80R38	142	35	305	358	183	215
380/85R46	146	46	344	405	207	243
380/90R46		6	148	174	89	104
380/90R46		12	201	237	121	142
380/90R46		17	265	312	159	187
380/90R46		23	321	377	192	226
380/90R46		29	355	417	213	250
380/90R46	149	35	373	439	224	263
380/90R50		6	152	179	91	107
380/90R50		12	213	250	128	150
380/90R50		17	271	319	163	191

Note: For single tires, multiply the above horsepower rating by 0.568. For triples, multiply the above horsepower

HORSEPOWER CAPACITIES AS DUALS

Main Drive Tire Size	Load Indicator/ Ply Rating	Inflation Pressure (PSI)	RECOMMENDED 5 MPH		3 MPH	
			2 WD	Front Assist	2 WD	Front Assist
380/90R50		23	334	393	200	236
380/90R50		29	362	426	217	256
380/90R50	151	35	396	466	238	280
380/90R54		6	156	184	94	110
380/90R54		12	224	264	135	158
380/90R54		17	288	339	173	203
380/90R54	146	23	344	405	207	243
380/90R54		29	386	454	232	272
420/80R46		6	152	179	91	107
420/80R46		12	213	250	128	150
420/80R46	139	17	280	329	168	197
420/80R46	145	23	334	393	200	236
420/80R46	149	29	373	439	224	263
420/80R46	151	35	396	466	238	280
420/80R46	156	46	459	540	275	324
420/80R46	159	52	503	592	302	355
480/70R34		6	144	169	86	102
480/70R34		12	201	237	121	142
480/70R34		17	258	303	155	182
480/70R34	143	23	313	368	188	221
480/70R34	146	29	344	405	207	243
480/70R34	155	46	446	525	268	315
480/85R34		6	172	202	103	121
480/85R34		12	237	279	142	167
480/85R34		17	305	358	183	215
480/85R34	149	23	373	439	224	263
480/80R38		6	172	202	103	121
480/80R38		12	237	279	142	167
480/80R38		17	305	358	183	215
480/80R38	149	23	373	439	224	263
480/80R42		6	178	210	107	126
480/80R42		12	250	294	150	177
480/80R42		17	321	377	192	226
480/80R42	151	23	396	466	238	280
480/80R46		6	190	223	114	134
480/80R46		12	265	312	159	187
480/80R46	145	17	334	393	200	236
480/80R46	152	23	409	482	246	289
480/80R46	155	29	446	525	268	315
480/80R46	158	35	488	574	293	344
480/80R50		6	195	229	117	138

Note: For single tires, multiply the above horsepower rating by 0.568. For triples, multiply the above horsepower

HORSEPOWER CAPACITIES AS DUALS

Main Drive Tire Size	Load Indicator/ Ply Rating	Inflation Pressure (PSI)	RECOMMENDED 5 MPH		3 MPH	
			2 WD	Front Assist	2 WD	Front Assist
480/80R50		12	271	319	163	191
480/80R50	147	17	355	417	213	250
480/80R50	154	23	430	506	258	304
480/80R50	157	29	475	558	285	335
480/80R50	159	35	503	592	302	355
520/85R38		6	201	237	121	142
520/85R38		12	288	339	173	203
520/85R38	148	17	362	426	217	256
520/85R38	155	23	446	525	268	315
520/85R42		6	213	250	128	150
520/85R42		12	296	348	178	209
520/85R42	150	17	386	454	232	272
520/85R42	157	23	475	558	285	335
520/85R46		6	224	264	135	158
520/85R46		12	313	368	188	221
520/85R46		17	396	466	238	280
520/85R46	158	23	488	574	293	344
540/65R30		6	148	174	89	104
540/65R30		12	207	243	124	146
540/65R30		17	265	312	159	187
540/65R30		23	313	368	188	221
540/65R30		29	355	417	213	250
540/65R30	150	35	386	454	232	272
540/65R34		6	156	184	94	110
540/65R34		12	218	256	131	154
540/65R34	140	17	288	339	173	203
540/65R34	145	23	334	393	200	236
580/70R38	155	23	446	525	268	315
600/70R30		6	190	223	114	134
600/70R30		12	271	319	163	191
600/70R30		17	344	405	207	243
600/70R30	152	23	409	482	246	289
620/75R30	163	35	558	656	335	394
620/70R42		6	237	279	142	167
620/70R42		12	334	393	200	236
620/70R42	153	17	420	494	252	296
620/70R42	160	23	516	607	310	364
620/70R46		6	244	287	146	172
620/70R46		12	344	405	207	243
620/70R46		17	446	525	268	315
620/70R46	162	23	548	644	329	387
650/75R32		12	334	393	200	236
650/75R32		17	430	506	258	304

Note: For single tires, multiply the above horsepower rating by 0.568. For triples, multiply the above horsepower

HORSEPOWER CAPACITIES AS DUALS

Main Drive Tire Size	Load Indicator/ Ply Rating	Inflation Pressure (PSI)	RECOMMENDED 5 MPH		3 MPH	
			2 WD	Front Assist	2 WD	Front Assist
650/75R32	160	23	516	607	310	364
650/75R32		29	574	675	344	405
650/75R32	167	35	626	736	375	442
650/75R32	172	46	725	853	435	512
650/75R34		6	244	287	146	172
650/75R34		12	344	405	207	243
650/75R34	155	17	446	525	268	315
650/75R34	162	23	548	644	329	387
650/75R34	168	29	641	755	385	453
650/85R38		6	288	339	173	203
650/85R38		12	409	482	246	289
650/85R38	160	17	516	607	310	364
650/85R38	167	23	626	736	375	442
650/85R38	170	29	688	810	413	486
650/85R38	173	35	746	877	447	526
650/65R42		6	229	270	138	162
650/65R42		12	321	377	192	226
650/65R42	153	17	420	494	252	296
650/65R42	158	23	488	574	293	344
650/65R42	162	29	548	644	329	387
650/65R42	165	35	594	699	357	420
650/65R42	170	46	688	810	413	486
710/70R38		6	280	329	168	197
710/70R38		12	386	454	232	272
710/70R38		17	503	592	302	355
710/70R38	166	23	610	718	366	431
710/70R42		6	288	339	173	203
710/70R42		12	409	482	246	289
710/70R42	160	17	516	607	310	364
710/70R42	168	23	641	755	385	453
800/65R32		12	396	466	238	280
800/65R32		17	503	592	302	355
800/65R32	167	23	626	736	375	442

Note: For single tires, multiply the above horsepower rating by 0.568. For triples, multiply the above horsepower rating by 1.397.

HORSEPOWER CAPACITIES AS DUALS

Main Drive Tire Size	Load Indicator/ Ply Rating	Inflation Pressure (PSI)	RECOMMENDED 5 MPH		3 MPH	
			2 WD	Front Assist	2 WD	Front Assist
800/65R32	169	29	667	785	400	471
800/65R32	172	35	725	853	435	512
800/70R38		6	334	393	200	236
800/70R38		12	475	558	285	335
800/70R38	166	17	610	718	366	431
800/70R38	173	23	746	877	447	526
900/65R32		6	344	405	207	243
900/65R32		12	475	558	285	335
900/65R32	166	17	610	718	366	431
900/65R32	172	23	725	853	435	512
900/50R42		6	296	348	178	209
900/50R42		12	409	482	246	289
900/50R42		17	532	626	319	375
900/50R42	168	23	641	755	385	453

Note: For single tires, multiply the above horsepower rating by 0.568. For triples, multiply the above horsepower rating by 1.397.

PROCEDURES FOR FILLING & REMOVING SOLUTION

WARNING: NEVER EXCEED RECOMMENDED OPERATING PRESSURE WHEN FILLING TIRE WITH SOLUTION OR REMOVING SOLUTION FROM TIRE.

Tube Type or Tubeless Tires

MIXING SOLUTION

Prepare the calcium chloride mixture by pouring the calcium chloride into the water (never the water into calcium chloride, as considerable heat is generated in this mixing process). The solution should be allowed to cool to atmospheric temperature before pumping in the tire. The pump can be used to mix and cool this solution by circulating it through the pump and back into the barrel with the pump running and handle moved right to fill position.

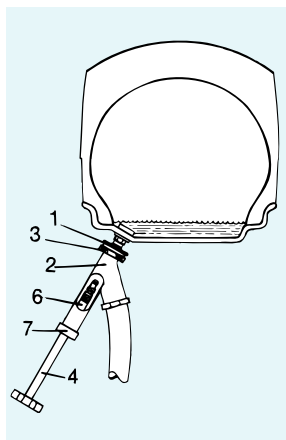

FIGURE 1

CONNECTING TO VALVE STEM

The following connections should be made when the pump is not running and with control handle in the vertical or check position: To connect liquid fill core ejector to 2 piece style rear tractor valves TR-218A, TR-618A, (figure 1), unscrew union (1) from core ejector body (2) screw on valve stem finger tight. Screw core ejector body on union (1) making sure rubber gasket (3) is in place, with handle (4) of core ejector pulled out. Push handle (4) of core ejector in until it makes contact with the core housing of the valve, then hold the core ejector in left hand, strike the handle (4) with the right hand to force the core housing in ejector chuck (6). Turn handle (4) to the left to unscrew the core housing, pushing inward lightly so you can feel the threads disengage when completely unscrewed. Then pull handle (4) out as far as it will go to retract core housing into ejector body. The handle will pull out easier if rotated while pulling, as packing nut (7) should be tight enough to prevent air or liquid leaks.

To connect liquid fill core ejector to 1 piece style front tractor valves TR415, TR413 (figure 2), screw adapter (A) and gasket to union (1). Insert large end of core remover (B) securely into chuck of core housing ejector (6). Screw adapter and union assembly on valve stem finger tight. Screw ejector union and adapter assembly to core ejector body making sure gasket is in place. The rest of the operation is the same as with the above 2 piece valve as described above.

REMOVING SOLUTION FROM TUBE-TYPE OR TUBELESS TIRE

Jack up tractor until tire is slightly deflected and valve is at the bottom. Connect core housing ejector and union to valve stem as previously described. Unscrew and retract core housing into ejector body with control handle at check position.

Start pump and turn control handle to evacuate position and run until tire is completely evacuated. Turn control handle to check position, stop pump and disconnect core ejector after replacing core housing in valve stem.

In case of a tubeless tire unseat beads and demount front bead from rim and pump remaining solution from tire.

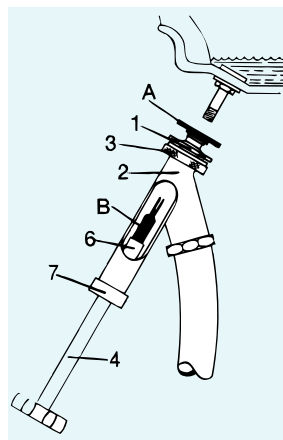

FIGURE 2

FILLING TUBE-TYPE OR TUBELESS TIRES WITH SOLUTION

To fill a tire 75% with water or solution: First inflate tire to 35 psi after beads have been fully seated in mounting procedure. Jack up the wheel, if done on a tractor, and turn to bring valve to top position. Then lower jack until tire is slightly deflected. With pump not running and control handle at check position, connect ejector and remove core housing as described above.

After connection is made, bleed pressure down to about 5 lbs. (to keep the beads seated on the rim) by moving control handle to left or evacuate position.

When this point is reached, start pump and move control handle to right or fill position. Start hydroinflating tire. Check pressure in tire every few minutes with pump gauge by placing pump in neutral or check position. If pressure exceeds 20 psi move handle to evacuate until pressure is bled back to not less than 5 psi. After pressure is lowered, continue pumping. Repeat above steps as often as may be necessary to fill until water or solution weight added to assembly is equal to that shown in the tables on previous pages.

Replace core housing in valve stem by pushing handle in until contact is made and turn to right until core housing is screwed tight in valve stem. Then withdraw handle, turn handle to evacuate, and pump all liquid from hose. Finally, shut off pump, then unscrew ejector body (2) and union (1) from valve.

To assure fully-seated beads inflate tire to 35 psi inflation pressure using a standard air line, and then with valve stem at the top, bleed pressure and excess water or solution down to 1-2 psi above recommended inflation.

Set final working pressure after tire has been mounted on tractor with weight on tire and valve at bottom, using an air-water gauge.

PUMP CARE AND MAINTENANCE

Drain Pump: If water or a weak solution of calcium chloride has been used, the pump should be removed from the barrel to prevent it from freezing.

Siphon Valve: To avoid solution or vacuum leakage, keep nut opposite handle tight to a point where handle will turn just a little hard.

Core Ejector: Packing nut (7) on plunger should be kept fairly tight to avoid leaks. However, do not set it so tight that plunger cannot be easily pushed into position. When not in use over long periods of time, keep items (2), (1), (A), and (B) in a bucket of clear water.

Solution in Pump: Do not pump all solution out of barrel. A small amount of solution is required to keep air out of pump and thus prevent corrosion and sticking. If water is used, be sure to place barrel where water will not freeze.

LIQUID WEIGHTING OF TRACTOR TIRES

Tube Type or Tubeless Tractor Tires

The traction or pulling power which a tire can exert is in proportion to the weight it carries. The greater the load on the tire, the more tractive effort it can exert. The way to secure more traction and reduce tire slippage and treadwear is add weight to the rear axle.

Filling tires with liquid is one of the most widely used methods of adding weight to the drive axle of a tractor because of its economy and simplicity. Plain water may be used where freezing never occurs. In colder climates where freezing temperatures occur, calcium chloride flake can be added at the strengths of 3.5 lbs. per gallon of water. For extremely cold climates, 5 lbs. of calcium chloride per gallon of water is used. Note that the calcium chloride not only provides freezing protection but also increases the weight added by 20% and 28% for 3.5 lb./gal. and 5 lb./gal. respectively. The following tables are for front and rear tractor tires filled to 75% or valve-level (valve at 12 o'clock position). Use of fill levels greater than this are not recommended because the tire becomes more susceptible to impact breaks. For a softer ride and better control of power hop, it is recommended that 40% fill (4 o'clock valve position) not be exceeded. Weights and amounts of fill for the 40% level are approximately half of those shown in the tables below. Liquid fill has a stiffening

effect on tire deflection, especially at lower inflation pressures. Because of this, use of liquid fill may make controlling power hop more difficult. For information on optimizing your tractor and eliminating power hop, see the section on Optimum Tractor Tire Performance.

Either tube-type or tubeless tires may be filled with calcium chloride solution. Rim corrosion is not a problem with tubeless tires as long as the tire is always kept inflated. This keeps outside air sealed away from the rim and restrains corrosion. A rim used tubeless with calcium chloride solution must be rinsed with tap water immediately after dismounting to prevent extremely rapid corrosion.

These tables are based on the use of Type 1-77% commercial calcium chloride flake. If type 2-94% calcium chloride flake is used, reduce the weight of calcium chloride added by 25%. Where anti-freeze protection is needed, the 3.5 lb./gal (420 g/l) solution is slush free to 12 F/ 24 C and will freeze solid at 52 F/ 47 C. The 5 lb./gal (600 g/l) solution is slush free to 52 F/ 47 C and will freeze solid at 62 F/ 52 C.

Front Tractor Tires 75% Fill

Tire Size	Water		3 1/2 lbs./420 g CaCl ₂			5 lbs./600 g CaCl ₂		
	Gal./Liters	Weight	Gal./Liters	CaCl ₂	Total Wt.	Gal./Liters	CaCl ₂	Total Wt.
		Lbs./Kg.						
4.00-12	2/8	17/7.7	1.7/7	6/2.7	20/9.1	1.6/6	8/3.6	21/9.5
4.00-15	2.5/10	21/9.5	2/8	7/3.2	24/11	2/8	10/4.5	27/12
5.00-15	4/15	33/15	3/12	10/4.5	35/16	3/12	15/6.8	40/18
5.50-16	5/19	42/19	4/15	14/6.4	47/21	4/15	20/9.1	53/24
6.00-14	6/23	50/23	5/19	18/8.2	60/27	5/19	25/11	67/30
6.00-16	6/23	50/23	5/19	18/8.2	60/27	5/19	25/11	67/30
6.50-16	7/27	58/26	6/23	21/9.5	71/32	5.5/21	28/13	74/34
7.50-10	6/23	50/23	5/19	18/8.2	60/27	4.8/18	24/11	64/29
7.5L-15	8.5/33	71/32	7/27	24/11	82/37	7/27	35/16	93/42
7.50-16	10/38	83/38	8.5/33	30/14	101/46	8/28	40/18	107/49
7.50-18	11/42	92/42	9.5/37	33/15	112/51	9/35	45/20	120/54
7.50-20	12/46	100/45	10/38	35/16	118/54	9.5/37	48/22	127/58
9.00-10	9/35	75/34	7.5/29	26/12	89/40	7.2/28	36/16	96/44
9.5L-15	11/42	92/42	9.5/37	33/15	112/51	9/35	45/20	120/54
9.50-15	18/69	150/68	16/62	56/25	189/86	15/58	75/34	200/91
9.50-20	18/69	150/68	16/62	56/25	189/86	15/58	72/33	200/91
9.50-24	20/77	167/77	17/65	60/27	202/92	16/62	80/36	213/97
10.00-16	18/69	150/68	16/62	56/25	189/86	15/58	69/31	184/84
11L-15	14/54	117/53	12/46	42/19	142/64	11/42	53/24	147/67
11L-16	15/58	123/56	13/50	46/21	155/70	12/46	60/27	160/73
11.00-15	24/92	200/91	20/77	70/32	237/108	19/73	95/43	253/115
11.00-16	25/96	208/94	22/85	77/35	260/118	20/77	93/42	267/121
14L-16.1	28/108	233/106	24/92	84/38	284/129	23/88	110/50	307/139
16.5L-16.1	41/158	342/155	35/135	122/55	414/188	33/127	167/76	440/200

Note: For 40% fill, multiply above values by 0.5.

Rear Tractor Tires 75% Fill

Tire Size	Water		3 1/2 lbs./420 g CaCl ₂			5 lbs./600 g CaCl ₂		
	Weight		Water	CaCl ₂	Total Wt.	Water	CaCl ₂	Total Wt.
	Gal./Liters	Lbs./Kg.	Gal./Liters	Lbs./Kg.	Lbs./Kg.	Gal./Liters	Lbs./Kg.	Lbs./Kg.
7.2-16	7/26	58/26	6/23	21/9.5	71/32	5/19	25/11	67/30
8.3-16	9/34	75/34	8/30	28/13	95/43	8/30	40/18	107/48
9.5-16	12/45	100/45	10/38	35/16	118/54	10/38	50/23	133/61
11.2-16	18/68	150/68	15/57	53/24	178/81	14/53	70/32	187/85
12.4-16	21/79	175/79	18/68	63/29	213/97	17/64	85/39	227/103
13.6-16.1	31/117	258/117	26/98	91/41	308/139	25/95	125/57	333/152
18.4-16.1	49/185	409/186	42/159	147/67	497/226	39/148	195/88	520/236
8.3-24	13/49	108/49	11/42	39/18	131/60	10/38	50/23	133/61
9.5-24	17/64	142/64	15/57	53/24	178/81	14/53	70/32	187/85
11.2-24	24/91	200/91	20/76	70/32	237/108	19/72	95/43	253/115
12.4-24	30/114	250/113	26/98	91/41	308/139	25/95	125/57	333/152
13.6-24	38/144	317/144	32/121	112/51	379/172	30/114	150/68	400/182
14.9-24	47/178	392/178	40/151	140/64	474/215	38/144	190/86	507/230
16.9-24	61/231	509/231	52/197	182/83	616/280	49/185	245/111	654/296
17.5L-24	55/208	459/208	47/178	165/75	557/253	45/170	225/102	600/272
19.5L-24	69/261	575/265	60/227	210/95	710/322	56/212	280/127	747/339
21L-24	87/329	725/329	74/280	259/117	876/397	70/265	350/159	934/424
14.9-26	48/182	400/181	41/155	144/65	486/220	39/148	195/88	520/236
16.9-26	65/246	542/246	56/212	196/89	663/301	52/197	260/118	694/315
18.4-26	79/299	659/299	68/257	238/108	805/365	64/242	320/145	854/387
23.1-26	128/485	1068/485	109/413	328/173	1291/586	103/390	515/234	1374/624
28L-26	157/594	1309/594	134/507	469/213	1587/720	127/481	635/288	1694/769
11.2-28	27/102	225/102	24/91	84/38	284/129	22/83	110/50	293/133
12.4-28	35/132	292/132	30/114	105/48	355/162	28/106	140/64	374/170
13.6-28	43/163	359/163	37/140	130/59	439/199	35/132	175/79	467/211
14.9-28	53/201	442/201	46/174	161/73	545/247	43/163	215/98	574/261
16.9-28	69/261	575/261	59/223	207/94	699/317	56/212	280/127	747/339
18.4-28	84/318	701/318	72/273	252/114	852/387	68/257	340/154	907/412
21L-28	97/367	809/367	83/314	291/132	982/446	79/299	395/179	1054/478
14.9-30	57/216	475/216	48/182	168/76	568/258	46/174	230/104	614/278
16.9-30	73/276	609/276	63/238	221/100	746/338	59/223	292/132	787/355
18.4-30	89/337	742/337	77/291	270/123	912/414	72/273	360/163	960/436
23.1-30	143/541	1193/541	123/466	431/196	1457/662	116/439	580/263	1547/702
24.5-32	170/643	1418/643	146/553	511/232	1729/785	138/522	690/313	1841/835
30.5L-32	217/821	1809/821	186/704	651/295	2202/999	176/666	880/399	2347/1065
35.5L-32	313/1287	2609/1287	291/1101	1019/462	3446/1563	275/1041	1375/624	3669/1665
14.9-34	63/238	525/238	54/204	189/86	639/290	51/193	255/116	680/309
16.9-34	82/310	684/310	70/265	245/111	829/376	66/250	330/150	880/400
18.4-34	100/379	834/378	85/322	298/135	1007/457	81/307	405/184	1081/491
20.8-34	128/485	1068/485	109/413	328/173	1291/586	103/390	515/234	1374/624
23.1-34	159/602	1326/602	136/515	476/216	1610/731	128/485	640/290	1708/775
13.9-36	51/193	425/193	44/167	154/70	521/237	42/159	210/95	560/254
13.6-38	57/216	475/216	49/185	172/78	581/263	46/174	230/104	614/278
15.5-38	66/250	550/250	56/212	196/89	663/301	53/201	265/120	707/321
16.9-38	90/341	751/341	77/291	270/123	912/414	73/276	365/166	974/442
18.4-38	110/416	917/416	94/356	329/149	1113/505	89/337	445/202	1187/539
20.8-38	140/530	1168/530	120/454	420/191	1421/645	114/431	570/259	1521/690
18.4-42	115/435	959/435	98/371	343/156	1160/527	93/352	465/211	1240/563
20.8-42	148/560	1234/560	127/481	444/202	1503/682	120/454	600/272	1600/726
14.9-46	80/303	667/303	68/257	238/108	805/365	65/246	325/147	867/393
18.4-46	129/488	1075/488	111/420	389/176	1314/596	105/397	525/238	1400/635
20.8-46	150/568	1251/568	128/384	448/203	1515/687	121/458	605/274	1614/732
Sure Grip Loader SS								
10-16.5	12/46	97/44	10/38	35/16	119/54	10/38	50/23	134/61
12-16.5	15/58	126/57	13/50	46/21	154/70	13/50	65/30	173/78
14-17.5	22/85	185/84	19/73	67/30	227/103	18/68	90/41	240/109
15-19.5	29/112	240/109	25/96	87/39	294/133	24/91	120/54	320/145

Note: For 40% fill, multiply above values by 0.5.

Metric Size Tires 75% Fill

Tire Size	Water				3-1/2 lbs./420 g CaCl ₂						5 lbs./600 g CaCl ₂							
	Gal.		Liters		Weight		Water		CaCl ₂		Total Wt.		Water		CaCl ₂		Total Wt.	
	Lbs.	Kg.	Lbs.	Kg.	Lbs.	Kg.	Lbs.	Kg.	Lbs.	Kg.	Lbs.	Kg.	Lbs.	Kg.	Lbs.	Kg.	Lbs.	Kg.
240/70R16	8	29	65	29	7	26	25	11	83	38	6	23	30	14	80	36		
250/80R16	12	46	101	46	10	38	35	16	118	54	10	38	50	23	133	60		
250/80R18	13	49	108	49	11	42	39	17	130	59	11	42	55	25	147	67		
250/95R34	24	90	197	90	20	76	70	32	237	107	19	72	95	43	253	115		
250/95R50	32	119	263	119	27	102	95	43	320	145	26	98	130	59	347	157		
260/70R16	10	37	81	37	8	30	28	13	95	43	8	30	40	18	107	48		
260/80R20	15	57	126	57	13	49	46	21	154	70	12	45	60	27	160	73		
290/95R34	34	130	287	130	29	110	102	46	343	156	28	106	140	64	373	169		
290/90R38	34	129	283	129	29	110	102	46	343	156	28	106	140	64	373	169		
320/70R24	23	87	192	87	20	76	70	32	237	107	19	72	95	43	253	115		
320/75R24	25	95	210	95	22	83	77	35	260	118	20	76	100	45	267	121		
320/85R34	38	144	316	144	33	125	116	52	391	177	31	117	155	70	413	188		
320/85R38	37	142	312	142	32	121	112	51	379	172	30	114	150	68	400	181		
320/80R42	40	153	336	153	35	132	123	56	414	188	33	125	165	75	440	200		
320/90R42	49	186	409	186	42	159	147	67	497	226	40	151	200	91	533	242		
320/90R46	52	195	430	195	44	167	154	70	521	236	42	159	210	95	560	254		
320/90R50	55	210	462	210	47	178	165	75	556	252	45	170	225	102	600	272		
320/90R54	56	210	463	210	48	182	168	76	568	258	45	170	225	102	600	272		
340/80R18	27	101	223	101	23	87	81	37	272	123	22	83	110	50	293	133		
340/85R46	57	214	472	214	49	185	172	78	580	263	46	174	230	104	614	278		
380/70R20	31	117	258	117	27	102	95	43	320	145	25	95	125	57	333	151		
380/70R24	36	136	299	136	31	117	109	49	367	166	29	110	145	66	387	175		
380/70R28	41	155	342	155	35	132	123	56	414	188	33	125	165	75	440	200		
380/85R28	50	188	414	188	43	163	151	68	509	231	40	151	200	91	533	242		
380/85R30	54	205	452	205	46	174	161	73	545	247	44	167	220	100	587	266		
380/85R34	56	213	470	213	48	182	168	76	568	258	46	174	230	104	614	278		
380/80R38	56	212	468	212	48	182	168	76	568	258	46	174	230	104	614	278		
380/90R46	76	287	631	287	65	246	228	103	769	349	61	231	305	138	814	369		
380/90R50	79	300	660	300	68	257	238	108	805	365	64	242	320	145	854	387		
380/90R54	84	319	702	319	72	273	252	114	852	387	68	257	340	154	907	411		
385/85R34MPT	60	226	497	226	51	193	179	81	604	274	48	182	240	109	640	290		
420/70R24	47	176	388	176	40	151	140	64	473	215	38	144	190	86	507	230		
420/70R28	53	200	441	200	45	170	158	71	533	242	43	163	215	98	573	260		
420/80R46	86	325	715	325	74	280	259	117	876	397	70	265	350	159	934	423		
420/85R28	66	249	549	249	56	212	196	89	663	301	53	201	265	120	707	321		
420/90R30	72	274	604	274	62	235	217	98	734	333	59	223	295	134	787	357		

Note: For 40% fill, multiply above values by 0.5.

Metric Size Tires 75% Fill

Tire Size	Water				3-1/2 lbs./420 g CaCl ₂						5 lbs./600 g CaCl ₂					
	Gal.		Liters		Water		CaCl ₂		Total Wt.		Water		CaCl ₂		Total Wt.	
	Lbs.	Kg.	Lbs.	Kg.	Lbs.	Kg.	Lbs.	Kg.	Lbs.	Kg.	Lbs.	Kg.	Lbs.	Kg.	Lbs.	Kg.
480/70R28	71	268	590	268	61	231	214	97	722	328	57	216	285	129	760	345
480/70R30	75	284	625	284	64	242	224	102	758	344	61	231	305	138	814	369
480/70R34	83	314	691	314	71	269	249	113	840	381	67	254	335	152	894	405
480/80R38	105	397	875	397	90	341	315	143	1065	483	85	322	425	193	1134	514
480/80R42	113	427	941	427	97	367	340	154	1148	521	92	348	460	209	1227	557
480/80R46	119	451	993	451	102	386	357	162	1207	548	97	367	485	220	1294	587
480/80R50	125	474	1044	474	107	405	375	170	1267	575	102	386	510	231	1360	617
480/85R34	99	376	829	376	85	322	298	135	1006	456	81	307	405	184	1080	490
VA500/95D32	138	521	1147	521	118	447	413	187	1397	634	112	424	560	254	1494	678
520/85R38	133	504	1111	504	114	431	399	181	1349	612	108	409	540	245	1440	653
520/85R42	142	537	1183	537	122	462	427	194	1444	655	115	435	575	261	1534	696
520/85R46	153	580	1278	580	131	496	459	208	1551	703	124	469	620	281	1654	750
540/65R30	80	304	671	304	69	261	242	110	817	370	65	246	325	147	867	393
580/70R38	142	536	1181	536	121	458	424	192	1432	650	115	435	575	261	1534	696
600/65R28	99	374	824	374	85	322	298	135	1006	456	80	303	400	181	1067	484
620/75R26	125	475	1046	475	108	409	378	171	1278	580	102	386	510	231	1360	617
620/70R42	169	641	1412	641	145	549	508	230	1716	779	137	519	685	311	1827	829
620/70R46	183	692	1523	692	157	594	550	249	1858	843	148	560	740	336	1974	895
650/75R32	162	613	1350	613	139	526	487	221	1645	746	131	496	655	297	1747	793
650/75R34	185	699	1539	699	158	598	553	251	1870	848	150	568	750	340	2001	907
650/85R38	229	865	1905	865	196	742	686	311	2320	1052	185	700	925	420	2467	1119
650/65R42	164	619	1364	619	140	530	490	222	1657	752	133	503	665	302	1774	805
710/70R38	201	763	1680	763	173	655	606	275	2048	929	163	617	815	370	2174	986
710/70R42	228	863	1901	863	195	738	683	310	2308	1047	185	700	925	420	2467	1119
750/65R26	168	635	1398	635	144	545	504	229	1705	773	136	515	680	308	1814	823
800/65R32	202	766	1687	766	173	655	606	275	2048	929	164	621	820	372	2187	992
800/70R38	265	1002	2208	1002	227	859	795	360	2687	1219	215	814	1075	488	2867	1301
900/50R42	235	888	1956	888	201	761	704	319	2379	1079	190	719	950	431	2534	1149
900/60R32	270	1022	2252	1022	231	874	809	367	2734	1240	219	829	1095	497	2921	1325
900/65R32	289	1096	2413	1096	248	939	868	394	2936	1332	235	889	1175	533	3134	1422

Note: For 40% fill, multiply above values by 0.5.

Terra-Tires 75% Fill

Tire Size	Water		3 1/2 lbs./420 g CaCl ₂			5 lbs./600 g CaCl ₂		
		Weight	Water	CaCl ₂	Total Wt.	Water	CaCl ₂	Total Wt.
	Gal./Liters	Lbs./Kg.	Gal./Liters	Lbs./Kg.	Lbs./Kg.	Gal./Liters	Lbs./Kg.	Lbs./Kg.
23x8.50-12NHS	6/23	50/23	5/19	18/8	60/27	5/19	25/11	67/30
23x10.50-12NHS	7/26	58/26	5/19	21/10	71/32	6/23	30/14	80/36
26x12.00-12NHS	10/38	83/38	9/34	31/14	106/48	8/30	40/18	107/49
25x8.50-14NHS	7/26	58/26	6/23	21/10	71/32	6/23	30/14	80/36
25x7.50-15NHS	6/23	50/23	5/19	18/8	60/27	5/19	25/11	67/30
25x10.50-15NHS	7/26	58/26	6/23	21/10	71/32	6/23	30/14	80/36
25x12.50-15NHS	8/30	67/30	7/26	25/11	83/38	7/26	35/16	93/42
27x8.50-15NHS	7/26	58/26	6/23	21/10	71/32	6/23	30/14	80/36
27x9.50-15NHS	9/34	75/34	8/30	28/13	94/43	7/26	35/16	93/42
27x10.50-15NHS	10/38	83/38	9/34	32/15	106/48	8/30	40/18	107/49
29x12.50-15NHS	14/53	116/53	12/45	42/19	142/64	11/42	55/25	146/66
31x12.50-15NHS	18/68	149/68	15/57	52/24	177/80	14/53	70/32	186/84
31x13.50-15NHS	19/72	158/72	16/61	56/25	189/86	18/68	75/34	200/91
31x15.50-15NHS	20/76	166/75	17/64	60/27	201/91	16/61	80/36	213/97
33x12.50-15NHS	22/83	183/83	19/72	66/30	224/102	18/68	90/41	239/108
36x13.50-15NHS	30/114	250/113	26/98	91/41	308/140	24/91	120/54	320/145
38x20.00-16.1NHS	42/159	349/158	36/136	126/57	425/193	34/129	170/77	452/205
38x14.00-20NHS	30/114	249/113	26/98	91/41	307/139	24/91	120/54	320/145
41x14.00-20NHS	32/121	267/121	27/102	95/43	320/145	26/98	130/59	347/157
42x25.00-20NHS	66/250	548/249	57/216	200/91	673/305	53/201	265/120	705/320
44x18.00-20NHS	56/212	476/216	48/182	168/76	566/257	45/170	225/102	548/249
44x41.00-20NHS	110/416	913/414	94/356	329/149	1109/503	88/333	440/200	1170/531
48x25.00-20NHS	92/348	764/347	79/299	277/126	933/423	74/280	370/168	984/446
48x31.00-20NHS	125/473	1038/471	107/405	375/170	1263/573	100/378	500/227	1330/603
48x20.00-24NHS	54/204	450/204	46/174	161/73	545/247	43/163	215/98	573/260
54x31.00-26NHS	117/443	975/442	100/378	350/159	1184/537	95/360	475/215	1267/575
66x43.00-25NHS	327/1238	2714/1231	280/1060	980/445	3304/1499	263/995	1315/596	3498/1587
66x44.00-25NHS	347/1313	2880/1306	298/1128	1043/473	3516/1595	279/1056	1395/633	3711/1683
67x34.00-25NHS	224/848	1859/843	192/727	672/305	2266/1028	180/681	900/408	2394/1086
67x34.00-26NHS	220/833	1826/828	188/712	659/299	2220/1007	176/666	882/400	2343/1063
67x34.00-30NHS	202/765	1677/761	173/655	606/275	2041/926	162/613	810/367	2155/978
73x44.00-32NHS	372/1408	3088/1401	318/1204	1113/505	3895/1767	299/1132	1495/678	3977/1804

Note: For 40% fill, multiply above values by 0.5.

RIM TYPES

Goodyear tires are designed to be used with rims having the dimensions of those shown as approved rims for the tire size in the Tire and Rim Association yearbook, current at the time of tire manufacture. Usage of other rims must be specifically approved by the Goodyear Tire and Rubber Company.

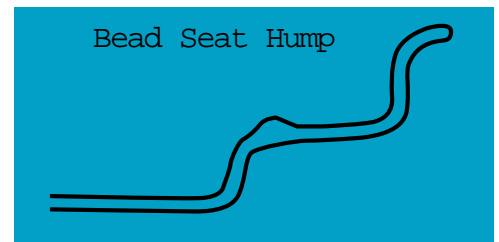
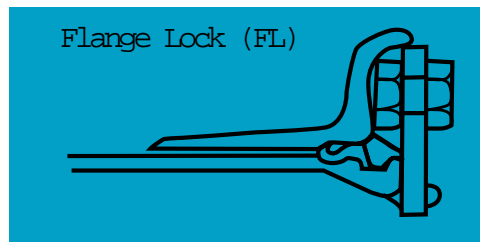
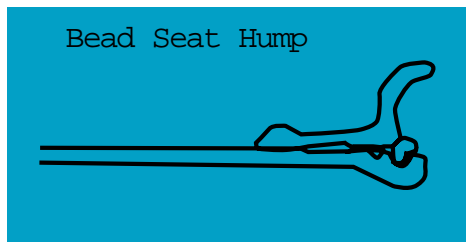
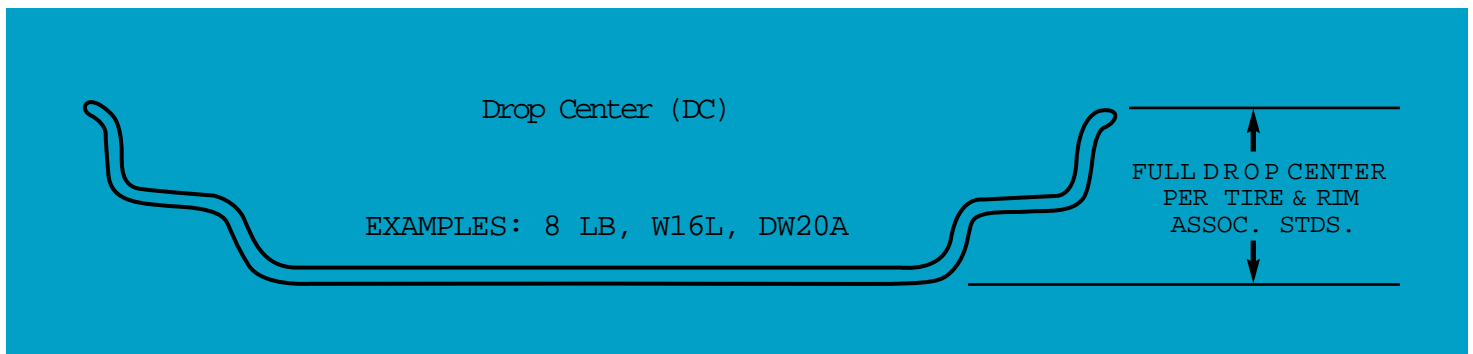
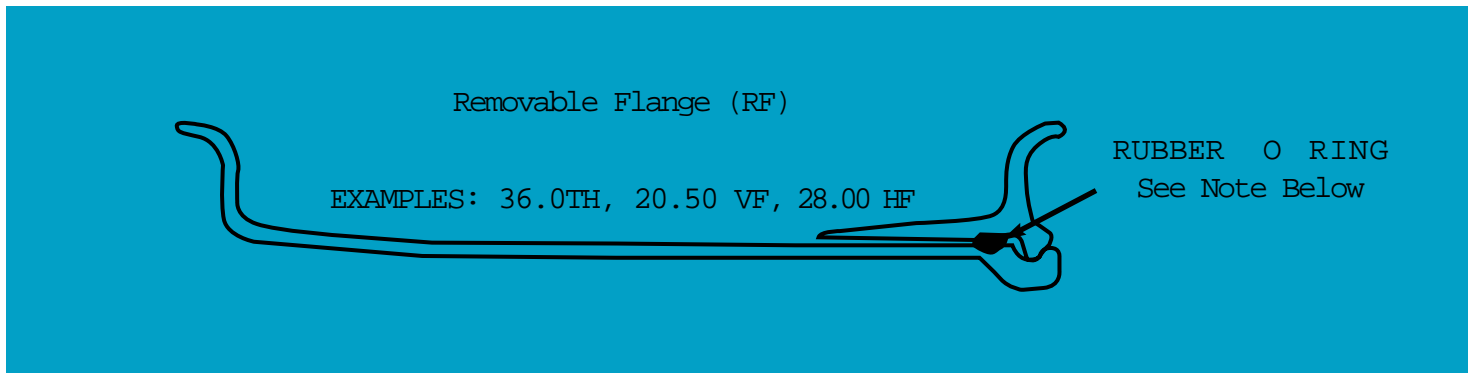

RIM TYPES:

1. Removable Flange (RF) Drop Center (DC) - These are conventional type rims used with tire sizes as specified on Pages 149-151. When available in both types, the RF rim is recommended for heavier loads and more severe service.
2. Flange Lock (FL) - Driving mechanism and flange locking device on (RF) rims, for use with a high torque application and/or low pressure (below 10 psi) to maintain air seal.
3. Bead Seat Hump - Available when specified on drop center and removable flange rims. For TERRA-TIRE[®] sizes which operate on side-slopes or rough terrain at inflation pressures of 10 psi or less.

NOTE: Rubber O Ring - 20" Dia. Rim Part #OR20JMH, 25" Dia. Rim Part #OR25TH, 32" Dia. Rim Part #OR32TH
(H-Goodyear Part Number)

Approved Rim Contours

For Agricultural Drive Wheel Tires (R1 thru R4)

Tire Size	Recommended Rim	Alternate Rim
7.2-16	6.00F	
7.2-30	W 6	
8.3-16	W 7	6.00F
8.3-24	W 7	
9.5-16	W8L, 8LB	
9.5-24	W8, W8H	W 7
9.5-36	W 8	
9.5-42	DW 8	
9.5-20	W 8	W 7
11.2-16	W10L, 10LB	
11.2-24	W10, W10H	W 9
11.2-28	W10, W10H	W 9
11.2-34	W10	
11.2-36	W9*	
11.2-38	W10	
12.4-16	W10L*, 10LB*	
12.4-24	W 11	W10, W10H
12.4-28	W 11	W10, W10H
12.4-36	DW 11A	DW 11
12.4-38	W 11, DW11A	W10, DW11
12.4-42	W9*	
13.6-16.1	W 11C*	
13.6-24	W 12	W 11
13.6-26	DW12A	W 11, DW11, DW12
13.6-28/13.6R28	W 12	W 11
13.6R28	W 12	W 11
13.6-38	W12, DW12A	W 11, DW12
13.9-36	W 12	
14.9-24/14.9R24	W 13	W 12
14.9-26	W12*, DW12A*	DW 12
14.9R26	W12*, DW12A*	DW 12
14.9-28	W 13	W 12
14.9R28	W 13	W 12
14.9-30	W 13	
14.9R30	W 13	
14.9R34	W12*	
14.9-38	W12*, DW12A*	DW 12
14.9R46	W 13	W 12
15.5-38	W14L, DW14A	DW 14
15.5R38	W14L, DW14A	DW 14
16.9-24	W15L	
16.9R24	W15L	
16.9-26	W15L	DW14, DW14A
16.9R26	W15L	DW14, DW14A
16.9-28	W15L	W14L
16.9R28	W15L	W14L
16.9-30	W15L, DW15A	W14L, DW14, DW15
16.9R30	W15L, DW15A	W14L, DW14, DW15
16.9-34	W15L	DW 14
16.9-38 DW 14	W15L	W14L, DW14A,
16.9R38 DW 14	W15L	W14L, DW14A,
16.9R38 DW 14	W15L	W14L, DW14A,

* Not Design Rim Width

IMPORTANT: Rim dimensions are standardized by The Tire and Rim Association for size and contour only, and particular tire and rim combinations are designated to assure proper mounting and fit of the tire to the rim. The load and cold inflation pressure imposed on the rim and wheel must not exceed the rim and wheel manufacturer's recommendations even though the tire may be approved for a higher load or inflation. Rims and wheels may be identified (stamped) with a maximum load and maximum cold inflation rating. For rims and wheels not so identified or for service conditions exceeding the rated capacities, consult the rim and wheel manufacturers to determine rim and wheel capacities for the intended service.

Tire Size	Recommended Rim	Alternate Rim
18.4-16.1	16.1x16LB, 16.1x16C	
18.4-24	W16L	W15L
18.4-26	DW16A	W15L, DW16
18.4R26	DW16A	W15L, DW16
18.4-28	W16L	W15L
18.4-30	DW16A	W15L, DW15, DW16
18.4-34	W16L, DW16A	W15L, DW16
18.4R34	W16L, DW16A	W15L, DW16
18.4-38	W16A, 16DD	W15L, W16L
18.4R38	W16A, 16DD	W15L, W16L
18.4-42	W16A, 16DD	W16L
18.4R42	W16A, 16DD	W16L
18.4R46	W16A, 16DD	
19.5L-24	W16L (NOT 12PR), DW16L	
19.5LR24	DW16L	
20.8-34	W18L	
20.8R34	W18L	
20.8-38	W18A, 18DD	W18L
20.8R38	W18A, 18DD	W18L
20.8-42	W18A, 18DD	W18LH
20.8R42	W18A, 18DD	W18LH
21L-24	W18L (10 PR), DW18L (10, 12, 16)	
21L-28	W18L (10 PR), DW18L (14 PR)	
23.1-26	DW20A-8, 10 PR	DW20-8PR DW20TB-8, 10 PR
23.1-30	DW20A	DW20
23.1-34	DW20A	DW20
24.5-32	DW21A-12 PR, DH21-12 & 16 PR	DW21TB-12 PR
24.5R32	DW21A, DH21	DW21TB
28L-26	DW25A	DW25-12 PR & UNDER, DW25TB
30.5L-32	DW27A, DH27	DW27-12 PR & DOWN, DW27TB-12 PR
30.5L-32VA	27.00 VA, (NO DW OR DH!)	
30.5LR32	DW27A, DH27	DW27, DW27TB

Approved Rim Contours

For Metric Size Agricultural Drive Wheel Tires (R1 thru R4)

Tire Size	Recommended Rim	Alternate Rim
240/70R16	W 8	W 9
250/80R16	W 8	W7, W9
250/80R18	W 8	W7, W9
250/95R34	W 8	
250/90R38	W 8	
250/95R50	W 8	
250/95R54	W 8 H	
260/70R16	W 8	W 9
260/80R20	W 8	
280/70R16	W 9	W10, W8
280/70R18	W 9	W10, W8
280/70R20	W 9	W10, W8
290/95R34	W10	
290/90R38	W 9	W10
290/90R42	W 9	W10
320/70R24	W10	W 11
320/75R24	W10	W 11
320/85R34	W10L	
320/85R38	W10	
320/80R42	W10	
320/90R42	W10	
320/90R46	W10A	DW10A
320/90R50	W10A	DW10A
320/90R54	W10A	
340/80R18	W 9	W 11
340/85R46	W12A	DW10A, W10A
380/70R20	W12	W 11, W13
380/70R24	W12	W 11, W13
380/70R28	W12	W 11, W13
380/85R28	W12	W 13
380/85R30	W12	W 13
380/85R34	W12	
380/80R38	W12	DW12A
380/95D38	DW10A	W10
380/85R46	W13A	DW13A, W12A
380/90R46	W12A	DW12A, DW13A, W13A
380/90R50	W12A	DW12A, DW13A, W13A
380/90R54	W12A	
400/70R18IND	13	W14L
400/70R20IND	13	W14L
420/70R24	W13	W12, W14L
420/70R28	W13	W12, W14L
420/85R28	W13	W14L
420/90R30	W13	W14L
420/85R34	W13	W15L, W14L
420/80R46	W13A	DW13A, W12A
440/80R28	W15L	W14L
480/70R28	W15L	W14L, W16L

Tire Size	Recommended Rim	Alternate Rim
480/70R30	W15L	W14L, W16L
480/70R34	W15L	W14L, W16L
480/80R38	W15L	16DD, W16A
480/80R42	W15L	16DD, W16A
480/80R46	W15L	16DD, W16A
480/80R50	DW15A	W15A
500/70R24IND	DW16A	
VA500/95D32	13.00VA	
520/70R30	W16L	W18L
520/85R38	W16A	18DD, W18A
520/85R42	W16A	18DD, W18A
520/85R46	W16A	W18A, 16DD
540/65R30	W16L	W18L, W15L
540/65R34	W16L	W18L, W15L
580/70R38	W18L	
600/65R28	W18L	
600/70R30	DW20A	W18L
620/75R26	DW20A	
620/75R30	DW20A	W18L, DW21A
620/70R42	DW20A	DW18A
620/70R46	DW20A	
650/75R32	DW21A	
650/75R34	DW20A	DW21A
650/85R38	DW20A	MW23A
650/65R42	DW20A	DW23A, DW18A*
710/70R38	MW23A	
710/70R42	MW23A	DW23A
750/65R26	DW25A	
800/65R32	DW27A	DW25A
800/70R38	DW25A	MW23A
900/50R32	DW27A	DW30A
900/60R32	DW27A	DW30A
900/65R32	DW27A	DW30A
900/50R42	DW28A	MW28A

*DW18A is an acceptable rim for the 650/65R42 size when used for retrofitting existing equipment only.

IMPORTANT: Rim dimensions are standardized by The Tire and Rim Association for size and contour only, and particular tire and rim combinations are designated to assure proper mounting and fit of the tire to the rim. The load and cold inflation pressure imposed on the rim and wheel must not exceed the rim and wheel manufacturer's recommendations even though the tire may be approved for a higher load or inflation. Rims and wheels may be identified (stamped) with a maximum load and maximum cold inflation rating. For rims and wheels not so identified or for service conditions exceeding the rated capacities, consult the rim and wheel manufacturers to determine rim and wheel capacities for the intended service.

APPROVED RIMS

FOR TERRA-TIRE^{fi} HIGH FLOTATION TIRES (HF-1 thru HF-4)

NOTE Goodyear tires are designed to be used with rims having the dimensions of those shown as approved rims for the tire size in the Tire and Rim Association Yearbook, current at the time of tire manufacture. Usage of other rims must be specifically approved by the Goodyear Tire and Rubber Company.

Tire Size	Rim Recom d	Alternate Rim
16 x 6.50-8 NHS	5.375 I	
18 x 6.50-8 NHS	5.375 I	
18 x 8.50-8 NHS	7.00 I	
18 x 9.50-8 NHS	7.00 I	
21 x 11.00-8 NHS	8.50 I	9.00 I
22 x 11.00-8 NHS	8.50 I	9.00 I
18 x 9.50-10 NHS	7.00 I	
20 x 8.00-10 NHS	6.00 I	6JA
26 x 12.00-12 NHS	10.50 I	8.50 I

Tire Size	Rim Recom d	Alternate Rim
25 x 7.50-15 NHS	6LB	
25 x 10.50-15 NHS	8LB	
25 x 12.50-15 NHS	10LB	
27 x 8.50-15 NHS	7JA	
27 x 9.50-15 NHS	7JJ	7JA
27 x 10.50-15 NHS	8LB	8JJ
29 x 12.50-15 NHS	10LB	10JJ
31 x 12.50-15 NHS	10LB	10JJ
31 x 13.50-15 NHS	10LB	
31 x 15.50-15 NHS	13LB	13JJ
33 x 12.50-15 NHS	10LB	
36 x 13.50-15 NHS	10LB	
38 x 20.00-16.1 NHS	W16C	
38 x 14.00-20 NHS	W11H	
41 x 14.00-20 NHS	W11H	
42 x 25.00-20 NHS	20.50VF	20.50HF
44 x 18.00-20 NHS	W14LH	
44 x 41.00-20 NHS	36.0VF	
48 x 25.00-20 NHS	20.50VF	20.50HF
48 x 31.00-20 NHS	26.00VF	26.00HF
66 x 43.00-25 NHS	36.0TH	See Notes Below
66 x 44.00-25 NHS	36.0TH	See Notes Below
67 x 34.00-25 NHS	30.0TH	See Notes Below
54 x 31.00-26 NHS	DW25A	DW26A
67 x 34.00-26 NHS	DW30	
67 x 34.00-30 NHS	DW30	
68x50.00-32NHS	DW44A	44DWM, DH44, DH44H
VA73 x 44.00-32 NHS	36.0VA	
DH73 x 44.00-32 NHS	DH36	

Flange Requirements for 25" Diameter Rim High Flotation Tires

Notes:

1. Proper bead fit on the rim is important for optimum tire performance and tire life especially for tires that are subjected to high deflections as encountered in variable load operations with spreader trucks and combines.
2. All 25" bead diameter Terra-Tire tires fit the TH rim with 1.5" flange height, with the exception of 20 PR tires. (See Note 3 below.) The 1.5" flange height rim provides optimum tire performance under all service conditions including the more severe service in variable load operations. Only the TH rim with 1.5" flange height should be used for the Goodyear Terra-Tire tires which require the 25" rim diameter.
3. Caution must be exercised in selecting the correct rim for 20 PR tires. There are two versions of 20 PR flotation tires. One uses the 1.5" flange height and the other uses a 2.5" flange height rim. Use only the correct tire and rim combinations for proper tire-to-rim fit.

APPROVED RIMS

For Garden Tractor Tires

Size	Recommended Rim	Alternate Rim
5-12 NHS	4JA	
6-12	5JA	
7-12 NHS	5JA	
7-14	5JA	
7-16	6.00F, 6L	6LB
8-16	6.00F, 6L	6LB

APPROVED RIM CONTOURS

For Agricultural Steering Wheel Tractor Tires (F-1 Thru F-3)

Size	Recommended Rim	Alternate Rim
4.00-12 4.00-15 4.00-19	3.00D	2.50C
5.00-15	3.00D	4J
5.50-16	4.00E	4.25KA, 4.50E, 5.00F
6.00-16 SL 6.00-14	4.00E 5KB	4.50E, 4.25KA
6.50-16 SL	4.50E	4.00E, 4.25KA, 5.00F
7.50-16 SL 7.50-18 SL 7.50-20 SL	5.50F 5.50F 5.50F	5.00F, 6LB 5.00F 5.00F
7.5L-15 SL	6LB, 6L	5K, 5KB
8.00-16 SL	5.50F	6.00G
9.00-10 NHS	6.00F (2 PIECE)	5.50F (2 PIECE)
9.5L-15 SL	8LB	
9.50-20 SL 9.50-24 SL	W7L W8, W8H	
10.00-16 SL	W8L, 8LB	
11L-15 11L-16 SL	8LB W8L, 8LB	10LB 10LB, W10L
11.00-16 SL 11.00-24 SL	W10L, 10LB W10, W10H	W8L, 8LB
14L-16.1 SL 14.5/75- 16.1 SL	16.1 x W11C 16.1 x W11C	
16.5L-16.1	16.1 x 14LB, 16.1 x W14C	

*Not Design Rim With

APPROVED RIMS

For ATV Tires

Tire Size	Rim Recommended	Alternate Rim
AT21 x 7-10	5.5 AT	
AT22 x 7-11	5.5 AT	
AT22 x 9-8	8.0 AT	
AT22 x 10-9	8.0 AT	
AT23 x 7-10	5.5 AT	
AT23 x 8-11	6.5 AT	
AT24 x 8-11	6.5 AT	
AT24 x 9-11	7.5 AT	
AT24 x 10-11	7.5 AT, 8.0 AT	
AT25 x 8-12	6.0 AT	
AT25 x 11-9	9.0 AT	
AT25 x 11-10	8.5 AT	

APPROVED RIMS

For Agricultural Implement Tires (I-1 Thru I-3)

Size	Recommended Rim	Alternate Rims
4.00-9	3.00D	
4.00-12 NHS	3.00D	2.50C
4.00-15 SL	3.00D	
4.00-18 SL	3.00D	
5.00-15 SL	3.00D	4J
5.50-16 SL	4.00E	4.25KA, 4.50E
5.90-15 SL	4 ¹ / ₂ KB, 4 ¹ / ₂ K	4J, 5K, 5KB
6.00-16 SL	4.00E	4.25KA, 4.50E
6.40-15 SL	4 ¹ / ₂ KB, 4 ¹ / ₂ K	4J, 5K, 5KB
6.50-16 SL	4.50E	4.00E, 4.25KA, 5.50F
6.70-15 SL	4 ¹ / ₂ KB, 4 ¹ / ₂ K	5K, 5KB
7.50-14 SL	5KB	5.50F
7.50-16 SL	5.50F	6LB
7.50-18 SL	5.50F	
7.50-20 SL	5.50F	
7.50-24 SL	W 7	
7.60-15 SL	6L, 6LB	
8.5L-14 SL	6KB	8KB
9.00-10 NHS	6.00F (2 PIECE)	5.50F (2 PIECE)
9.00-16 SL	6 LB	5.50F, W8L, 8LB
9.00-24 SL	W8 (6 PR), W8H (6 & 8 PR)	W7 (6 PR)
9.5L-14 SL	8KB*	
9.5L-15 SL	8LB*	
10.00-15 SL	8LB	
11L-14 SL	8KB	
11L-15 SL	8LB	10LB
11L-16 SL	W8L, 8LB	10LB, W10L
11.25-24 SL	W10H, W10	W8H, W8
11.25-28 SL	W10H, W10	
12.5L-15 SL	10LB	
12.5L-16 SL	W10L, 10LB	
13.50-16.1 SL	16.1XW11C	
14L-16.1 SL	16.1XW11C	
16.5L-16.1 SL	16.1X14LB, 16.1XW14C	
19L-16.1 SL	16.1X16LB, 16.1XW16C	
21.5L-16.1 SL	16.1XW18C	16.1X16LB, 16.1XW16C

*Consult tire manufacturers for bead/flange fit.

*Not Design Rim With

Size	Recommended Rim	Alternate Rims
9.5L-15FI	8LB	
11L-15FI	8LB	10LB
12.5L-15FI	10LB	

IMPORTANT: Rim dimensions are standardized by The Tire and Rim Association for size and contour only, and particular tire and rim combinations are designated to assure proper mounting and fit of the tire to the rim. The load and cold inflation pressure imposed on the rim and wheel must not exceed the rim and wheel manufacturer's recommendations even though the tire may be approved for a higher load or inflation. Rims and wheels may be identified (stamped) with a maximum load and maximum cold inflation rating. For rims and wheels not so identified or for service conditions exceeding the rated capabilities, consult the rim and wheel manufacturers to determine rim and wheel capacities for the intended service.

TIRE SERVICE & MAINTENANCE

SAFETY PRECAUTIONS

1. NEVER reinflate a tire that has been operated in a run-flat or underinflated condition (80% or less of recommended pressure). Deflate, demount and inspect all tire and rim parts before reinflating.
2. ALWAYS use specialized tools as stated below for mounting and demounting of tires.
3. NEVER attempt to unseat beads of an inflated tire.
4. BEFORE loosening any nuts or clamps that attach the rim assembly to a vehicle, always completely deflate the tire (both tires of a dual assembly) by taking out the valve core(s). Run a wire thru valve to make sure it is clear. Never attempt to demount a tire from a rim unless you are sure that the tire is completely deflated. Failure to follow this practice can cause the assembly to burst with force sufficient to cause serious injury or death.
5. NEVER use any rim part that is bent, pitted from corrosion, cracked or worn. These are unserviceable parts and must be destroyed so that they cannot be used. Remove rust, dirt or foreign material from rim parts.
6. NEVER use a rim part unless you can positively identify it from the manufacturer's stamped markings. If you cannot identify a part, it must be destroyed.
7. ALWAYS inspect inside of tire for loose cards, cuts, penetrating objects or other casing damage. Repairable damage must be repaired before placing tire back into service. Tires with unrepairable damage should be destroyed.
8. ALWAYS clean and inspect rim.
9. NEVER rework, weld, heat, or braze rims.
10. ALWAYS check rim diameter to be sure it exactly matches rim diameter molded on tire.
11. NEVER substitute an innertube for a permissible or non-permissible repair.
12. ALWAYS replace a tire with one having the same rim diameter designation and suffix letters.
13. ALWAYS inspect inside of the tire and remove dirt, liquids, or other foreign material before mounting.
14. NEVER install tubes that have buckled or been creased.
15. ALWAYS use new tubes in new tires.
16. ALWAYS use radial tubes with radial tires.
17. NEVER use a tube in a casing larger or smaller than that for which the tube was designed by the manufacturer.
18. ALWAYS check to be sure tube is clean before installing in tire.
19. ALWAYS lubricate with only approved tire mounting lubricant or mild vegetable oil soap solution. Never use antifreeze, silicones or petroleum-base lubricants. This will damage the tire.
20. On drop center rims, do not exert excessive force prying beads over rim flange. Be sure portion of bead over rim flange is down in the well of the rim and pry only small portions of the bead over the rim flange at one time.
21. On demountable flat base rims be certain the lock ring is seated properly in rim base groove before starting inflation. Do not hammer on flange or lock ring during or after tire is inflated.
22. NEVER hit tire or rim with hammer.
23. ALWAYS inspect valve cores for proper air retention. Replace damaged or leaky cores.
24. ALWAYS inflate tire to vehicle manufacturer's recommended cold inflation pressure for the tires intended service and make sure it does not exceed the maximum inflation pressure molded on the sidewall.
25. When inflating a tire of a vehicle, use a safety cage or other restraining device, and an extension hose with in-line air gauge and clip-on air chuck, which allows the operator to stand clear of the trajectory. See diagram on page 156.
26. For tube-type tires, inflate to service pressure without the valve core installed and then completely deflate the tire to prevent wrinkles in the tube. Insert the valve core and reinflate the tire to recommended service pressure as specified by the vehicle manufacturer.
27. ALWAYS use sealing valve caps to prevent loss of air or fluid.

TYPICAL TOOL REQUIREMENTS

Bead unseating tool
Rubber mallet (for unseating beads)
36" tire irons (2)
18" tire irons (2)
Wire brush
Approved tire mounting lubricant
Extension hose with in-line gauge and clip-on air chuck
Air/water inflation gauge*
Restraining device

BEFORE MOUNTING

tire on a used rim, be sure flange area (particularly the bead seat area) is clean and smooth. Remove any buildup of rust, corrosion or old rubber with a wire brush. Never mount a tire on a rim where any parts show cracks, damage, or have been repaired by welding or brazing, or where the rim or rim parts cannot be accurately identified. Thoroughly inspect inside of casing for damage or foreign material, and remove dirt, liquids, or other foreign material before mounting. Lubricate both beads with a thin solution of vegetable oil soap in water, or equivalent rubber lubricant recommended for this requirement. (Never use petroleum-base solutions or silicones.)

ING! **WARN-**

NEVER inflate beyond 35 pounds of pressure to seat beads.

If beads have not seated by the time pressure reaches 35 psi, deflate the assembly, reposition the tire on the rim, re-lubricate and re-inflate. After seating beads, adjust inflation to recommended pressure. Allowing air pressure to build within the assembly in an attempt to seat the beads is a DANGEROUS PRACTICE. In seating beads, inflation beyond 35 pounds pressure may break the bead (or even the rim) with explosive force sufficient to cause SERIOUS PHYSICAL INJURY OR DEATH. Inspect both sides of the tire to be sure beads are evenly seated. If not, completely deflate tire,

*For tubeless drive tires with TR618A valve use large bore air chuck, Schrader No. 4660A, Dill No. 9308 and air through spud.

TIRE DEMOUNTING AND MOUNTING SAFETY PRECAUTIONS



WARNING

SERIOUS INJURY OR DEATH MAY RESULT FROM:

EXPLOSION OF TIRE/RIM/WHEEL ASSEMBLY DUE TO IMPROPER MOUNTING NEVER EXCEED 35 PSI (AIR PRESSURE) WHEN SEATING BEADS. ALWAYS USE SAFETY CAGE OR OTHER RESTRAINING DEVICE AND CLIP-ON EXTENSION HOSE. ONLY SPECIALLY TRAINED PERSONS SHOULD MOUNT TIRES.

TIRE FAILURE DUE TO MISAPPLICATION/IMPROPER INFLATION/OVERLOADING/EXCEEDING MAXIMUM SPEED FOLLOW TIRE MANUFACTURER S INSTRUCTIONS. CHECK INFLATION PRESSURE FREQUENTLY WITH GAUGE.

EXPLOSION OF THE TIRE/RIM/WHEEL ASSEMBLY DUE TO WELDING THE RIM WITHOUT FIRST REMOVING THE TIRE NEVER REWORK, WELD, HEAT OR BRAZE THE RIM OF A TIRE/RIM/WHEEL ASSEMBLY.



WARNING

TIRE CHANGING CAN BE DANGEROUS AND SHOULD BE DONE BY TRAINED PERSONNEL USING PROPER TOOLS AND PROCEDURES. ALWAYS READ AND UNDERSTAND ANY MANUFACTURER S WARNING CONTAINED IN THEIR CUSTOMER S LITERATURE OR MOLDED INTO THE TIRE SIDEWALL.

Failure to comply with these procedures may result in faulty positioning of the tire and/or rim parts, and cause the assembly to burst with explosive force, sufficient to cause serious physical injury or death. Never mount or use damaged tires or rims.



WARNING

NEVER inflate beyond 35 pounds of pressure to seat beads. NEVER stand, lean or reach over the assembly during inflation. Inspect both sides of the tire to be sure that the beads are evenly seated. If tire is mounted on a machine that does not have a positive lock-down device to hold the wheel, inflation should be done in a safety cage or other restraining device. If both beads are not properly seated when pressure reaches 35 psi, completely deflate the assembly, reposition the tire and/or tube on the rim, relubricate and reinflate. Inflating beyond 35 psi air pressure when trying to seat the beads is a DANGEROUS PRACTICE that may break a tire bead (or even the rim) with explosive force, possibly resulting in serious injury or death. After the beads are fully seated, pressure may be increased above 35 psi to operating pressures, not to exceed the maximum molded on the tire sidewall.



WARNING

Reinflation of any type of tire/rim assembly that has been operated in a run-flat or underinflated condition (80% or less of recommended pressure), can result in serious injury or death. The tire may be damaged on the inside and can explode while you are adding air. The rim parts may be worn, damaged or dislodged and can explosively separate. NEVER rework, weld, heat, or braze the tire/wheel/rim. Heating the rim of tire/wheel/rim assembly can cause a tire to explode, causing serious injury or death.

The use of any flammable material during tire servicing is absolutely prohibited. Use of starting fluid, ether, gasoline or any other flammable material to lubricate, seal or seat the beads of a tubeless tire can cause the tire to explode or can cause the explosive separation of the tire/rim assembly resulting in serious injury or death.

NEVER hammer, strike or pry on any type of tire/rim assembly while the tire contains inflation pressure. Do not attempt to seat any part while the tire contains any inflation pressure. This could result in serious injury or death.

TIRE DEMOUNTING AND MOUNTING SAFETY PRECAUTIONS

WARNING

There is a danger of serious injury or death if a tire of one bead diameter is installed on a rim or wheel of a different rim diameter.

Always replace a tire with another tire of exactly the same bead diameter designation and suffix letters.

For example: A 16" tire goes on a 16" rim. Never mount a 16" tire on a 16.1" or 16.5" rim. A 16.1" tire goes on a 16.1" rim. Never mount a 16.1" tire on a 16" or 16.5" rim. A 16.5" tire goes on a 16.5" rim. Never mount a 16.5" tire on a 16" or 16.1" rim. For the same reason, never mount a 26" rim diameter tire on a 26.5" rim. Never mount a 30" rim diameter tire on a 30.5" rim.

While it is possible to pass a 16" diameter tire over the lip or flange of a 16.1" or 16.5" size diameter rim, it cannot be inflated enough to position itself against the rim flange. If an attempt is made to seat the tire bead by inflating, the tire bead will break with explosive force and could cause serious injury or death.

Rims of different diameters and tapers cannot be interchanged. The following diagram illustrates the difference between rims of two different tapers and diameters:

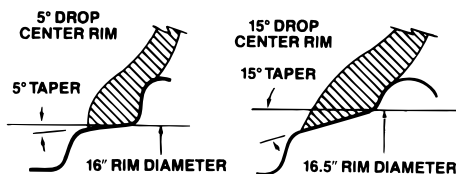

The following diagram shows how beads of a 16" tire will not seat on a 16.5" rim. The beads cannot be forced out against the rim flanges by using more air pressure because this will break the beads and the tire will explode with force sufficient to cause serious injury or death.

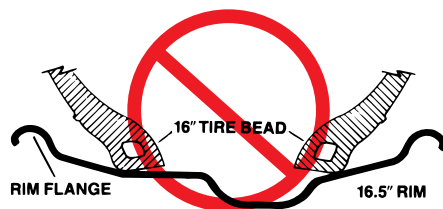

WARNING

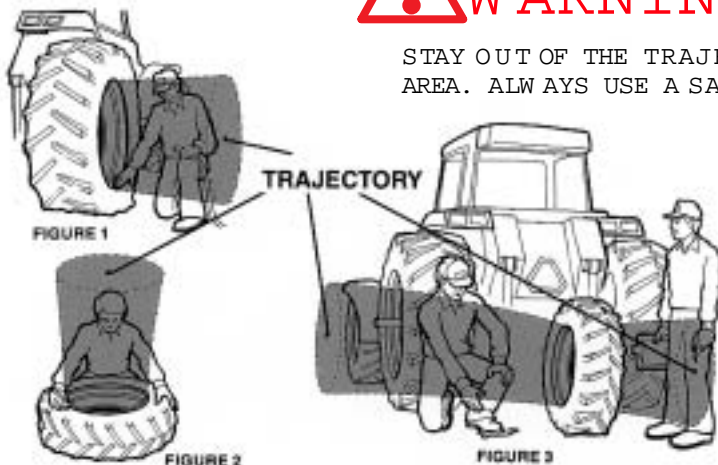

STAY OUT OF THE TRAJECTORY AS INDICATED BY SHADED AREA. ALWAYS USE A SAFETY CAGE OR OTHER RESTRAINING DEVICE IN COMPLIANCE WITH OSHA REGULATIONS.

Note: Under some circumstances, the trajectory may deviate from its expected path.

TIRE DEMOUNTING AND MOUNTING SAFETY PRECAUTIONS



15.3" DIAMETER: 9" WIDTH EUROPEAN RIMS

Certain European farm implement equipment has been imported into North America with unique diameter rims for which no North American produced replacement tire sizes are available.

Any attempt to mount and inflate 15" nominal bead diameter tires on these rims may ultimately cause one of the tire beads to break, possibly resulting in serious physical injury or even death.

The rims in question are 15.3" in diameter and 9" wide. However, rims manufactured in 1981 and earlier are marked as 15" diameter; only those manufactured in 1982 and 1983 are marked as 15.3" diameter. The key to avoiding this potentially dangerous situation is the 9" width. The U.S.A. (or Canada) wheel industry does not manufacture a 9" width rim for farm implement use.

The European tire sizes that may be mounted on these rims are:

10.0/75 15.3 (or 15)
10.5/85 15.3
11.5/80 15.3 (or 15)
12.5/80 15.3

U.S.A. (OR CANADA) PRODUCED FARM IMPLEMENT TIRES ARE NOT TO BE MOUNTED ON ANY 9" WIDE FARM IMPLEMENT RIM.

TO DETERMINE COMPATIBLE RIM WIDTH FOR TIRE SIZES

Determine the vehicle's actual rim width by measuring, in inches, the distance between the vertical bead flanges as shown. A simple ruler or yardstick may be used, as rims are manufactured in half inch increments of width.

Find permissible replacement tire sizes in RMA's Care and Service of Farm Tires Manual (available from the address below). Most tires will fit on more than one rim width.

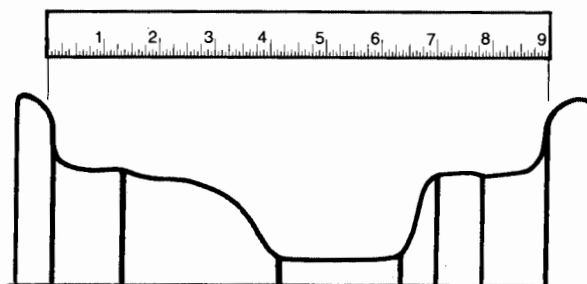

EXAMPLE OF A 9" RIM WIDTH

1. Courtesy of RMA

MOUNTING OFF THE VEHICLE

DROP CENTER RIMS



1. Lay the rim on the floor with the narrow ledge on the top. Thoroughly lubricate the tire bead area and rim flange with an approved tire mounting lubricant or a thin solution of vegetable oil soap in water. (Never use antifreeze, silicones or petroleum-base lubricants because this will damage the tire.)



4. Starting opposite the valve, use tire irons to lever the top bead over the rim flange and down into the rim well. Be careful to avoid pinching the tube with tire irons. Locking pliers may be used to keep your place. When the bead is well started, lubricate the remaining unmounted portion of the tire bead and rim flange. Taking small bites, spoon the tire bead over the rim flange until the final section drops over at the valve.

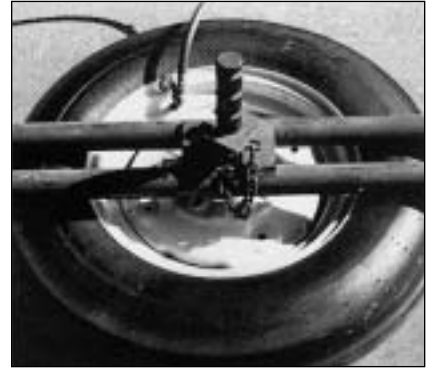

2. For tube-type tires push the bottom bead over the rim flange as far as possible. Use 18" tire irons to work the first tire bead completely over the rim flange, taking small bites and being careful not to damage the bead.



5. Thoroughly lubricate the tire bead area and rim bead seats on both sides of the tire.



3. For tube-type tires partially inflate the tube and insert it into the tire casing with the valve located near the valve hole in the rim. Attach a valve retrieval tool to the valve and thread the tool through the valve hole. (Inserting the tube and attaching the tool may be eased by placing a block under the tire.)



6. Centering the tire on the rim is extremely important to prevent broken beads. Use an extension hose with an in-line air gauge and clip-on chuck; and place tire/rim/wheel in a safety cage or other restraining device. Inflate the tire (with the valve core removed) to seat the beads. Do not exceed 35 psi. See WARNING. It is essential for the operator to stand clear of the tire. Check to see that both beads are seated all the way around the tire.

If the tire is tube-type, completely deflate (to allow repositioning of the tube) by removing the valve core housing.

For tubeless tires, mounting depends on how well the shape of the tire has been maintained. If the beads are in or near their molded position, they can be seated by inflating the tire, through the valve spud. Where the beads have been squeezed together, the use of an inflator ring (either horizontally or vertically) will be required to provide a seal between the tire bead and rim. Re-insert the valve core and re-inflate the tire to the vehicle manufacturer's recommended operating pressure.

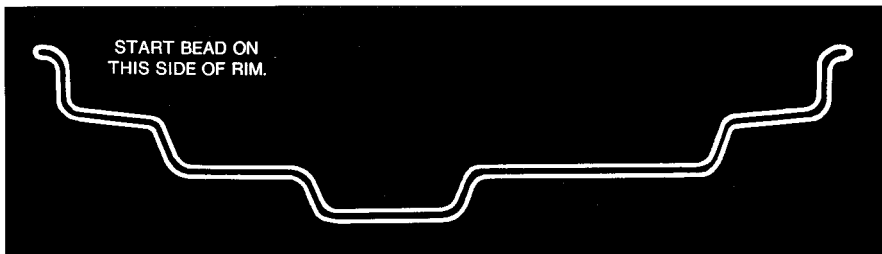

MOUNTING ON THE VEHICLE

DROP CENTER RIMS



1. Thoroughly lubricate the tire bead area and rim flange with an approved tire mounting lubricant or a thin solution of vegetable oil soap in water. (Never use antifreeze, silicones or petroleum-base lubricants because this will damage the tire.)



4. Relubricate the tire beads and rim flange. In tube-type tires the tube should be partially inflated and base area that contacts the rim should be lubricated to prevent localized stretching.



7. With the valve stem at the bottom, lower the jack until the tire is centered on the rim. Centering of the tire and rim assembly is extremely important to prevent broken beads. Using an extension hose with an in-line air gauge and clip-on chuck (with valve core removed), inflate the tire to seat the beads.

Do not exceed 35 psi. see WARNING. It is essential for the operator to stand clear of the tire. Check to see that both beads are seated all the way around the tire.

For tubeless tires, mounting depends on how well the shape of the tire has been maintained. If the beads are in or near their molded position, they can be seated by inflating the tire, through the valve spud. Where the beads have been squeezed together, the use of an inflator ring (either horizontally or vertically) will be required to provide a seal between the tire bead and rim.



2. Before placing tire on rim, be sure valve hole of rim is at bottom of wheel. To put the tire on the wheel, place the inner bead over the flange at the top. Be sure the bead is not hung up on the bead seat, but that the bead is guided into the rim well, while the tire irons and/or rubber mallet are used to work the first bead over the rim. With the first bead on the rim, pull the tire toward the outside of the rim as far as possible to make room for the tube.



5. Starting at the top, use the tire irons to lift the outer bead up and over the rim flange, then down into the rim well. Be careful not to pinch the tube in this operation.



3. Before inserting a tube in a tube-type tire, be sure the valve is at the bottom of the wheel. Align the stem with the valve hole and place the tube in the tire, starting at the bottom. Place the valve in the valve hole and screw the rim nut in place. Be sure that the tube is well inside the rim before proceeding to the next step.



6. After getting the first section of the outer bead into the rim well, place one hand against that section to hold it and then pry the remainder of the bead over the flange with the tire iron in the other hand.



8. Raise the vehicle and rotate wheel assembly to have the valve at the top. If the tire is tube-type, completely deflate by removing the valve core housing. Re-insert the valve core and re-inflate the tire to the recommended operating pressure.

DEMOUNTING OFF THE VEHICLE

DROP CENTER RIMS

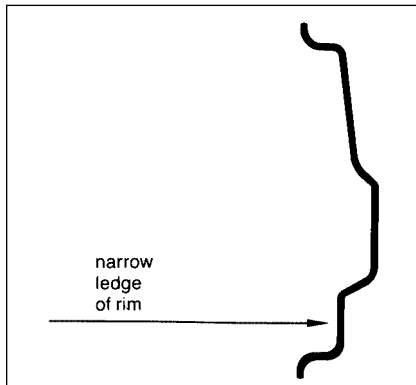

1. Remove any fill from the tire. Remove the valve core and completely deflate the tire. Lay the assembly on the floor with the narrow ledge on the bottom.



2. Drive a bead unseating tool between the tire bead and rim flange, being careful not to damage the tire bead area. After the bead has been released completely around the tire, turn the tire and rim over and repeat the bead unseating procedure with the narrow ledge up (as shown above).



3. With the narrow ledge on top, thoroughly lubricate the rim flange and tire bead area with an approved tire lubricant or a thin solution of vegetable oil soap in water. (Never use antifreeze, silicones or petroleum-base lubricants.)



4. Force the part of the bead that is directly across from the valve into the well. Starting at the valve, pry the bead over the rim flange using two 18" long tire irons. Continue by taking small bites to avoid damage to bead until the top bead is completely over the rim flange.



5. Bring the assembly to an upright position and pull the tube out of the tire. If only the tube requires repair or replacement, this can be removed, repaired, and replaced in the tire without removing the tire completely from the rim. Thoroughly inspect the inside of the casing for damage or other foreign material. Remove any remaining fluid from inside the tire.



6. To completely remove the tire from the rim, turn assembly over so the narrow ledge is down and lubricate the second tire bead and rim flange. Be sure the one side of the bead still on the rim is in the rim well and insert the tire irons under the opposite side of the bead. Work the rim slowly out of the tire by taking small bites alternately using both tire irons.

DEMOUNTING ON THE VEHICLE

DROP CENTER RIMS

(Some steps for the following procedure may require two persons on larger size tires.)



1. Jack up the vehicle, then remove the fluid fill from the tire. Deflate the tire by removing the valve core housing. For tube-type tires, remove the rim nut and push the valve through the valve hole.



4. Lock the wheel with the valve at the top. Force the outside bead at the bottom into the well. Insert long tire irons under the bead at the top and pry the bead over the rim flange. Take small bites to avoid extremely hard prying, which will damage the tire bead.



6. Pull the tube out of the casing, starting at the bottom. If only the tube requires repair or replacement, this can be removed, repaired, and replaced in the tire without removing the tire completely from the wheel. Before re-installing the tube, thoroughly inspect the inside of the casing for damage or other foreign material. Remove any remaining fluid from inside the tire.



2. After the tire is completely deflated, place a hydraulic bead unseating tool between the tire bead and rim flange and force the bead off the bead seat. Be careful not to damage the tire's bead area. The beads should be unseated on both sides of the rim.



5. After the first section of the bead is over the rim flange, use one tire iron to hold that section over the flange and use another tire iron to pry the next section over the flange. Do not attempt to pry too large a section of the bead over the rim flange at one time. Never release your grip on either iron, as they may spring back.



7. To remove the tire completely from the wheel, insert tire irons under the inside bead at the side of the tire. Pry the rest of the inside bead over the rim flange. When starting this operation, be sure that the bead area on the opposite side of the tire is down in the well of the rim.



3. Thoroughly lubricate the tire bead area and rim flange with an approved tire mounting lubricant or a thin solution of vegetable oil soap in water. (Never use antifreeze, silicones or petroleum-base lubricants because this will damage the tire.)

REMOVABLE FLANGE RIMS MOUNTING INSTRUCTIONS

SEE SAFETY
PRECAUTIONS -
PAGES
154-157

T G, VA, T, TH,

JM RIMS

MOUNTING

Procedure Requires the following equipment:

One (1) TO-399 tool. Two (2) TO-799 tools. Rubber lubricant*. Babbit hammer.

NOTE: Install valve spud in the rim and tighten to proper torque before proceeding with mounting.

Tire mounting 20" bead dia and larger or flat base rims lube with water only. 15" & 16.1 drop center rims use thin vegetable soap solution on both tire beads and rim flanges.



1. Check rim bead seat area and rubber O ring groove to be certain there are no rough spots that may cause air leak. Place rim base on floor with flange side down. Place tire over rim base.



2. Place side flange over rim and push straight down as far as possible which will expose the two grooves on the rim base.

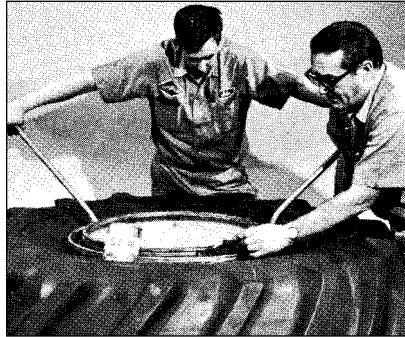

3. Lubricate* the rubber O ring and place into lower (inside) groove on one side and stretch and place it into groove. (Do not roll O ring) NOTE It may be necessary to hold side flange down with the flat end of tool TO-799 to expose O ring groove.



4. Install lock ring by placing one end in the top groove, pressing the ring into place. Be sure the embossed safety bulge on the ring is facing outward. It may be necessary (or expedient) to tap the end into place. The ring should fit snugly in the groove at all points for safe inflation.



5. Before inflating the tire to the desired pressure, make sure the lock ring is snugly against the rim base around its entire circumference. Due to the tubeless feature a high volume of air is required for initial bead seal. If necessary to seal beads, insert a slightly inflated and lubricated 4.00-19 motorcycle tube (or similar size tube) between rim flange and tire bead. Once beads have started to seat, pull inner tube off quickly to prevent it from being pinched between bead and rim flange. AGAIN, MAKE SURE THE LOCK RING IS IN ITS PROPER GROOVE COMPLETELY AROUND THE RIM BEFORE INFLATING THE TIRE TO OPERATING PRESSURE. Always place mounted tire/rim assembly in a safety cage when inflating a tire mounted on a multi-piece (Removable flange) rim.

NOTE: SEE SAFETY
PRECAUTIONS
PAGES 154-157

NOTE: Goodyear tires are designed to be used with rims having the dimensions of those shown as approved rims for the tire size in the Tire and Rim Association yearbook, current at the time of tire manufacture. Usage of other rims must be specifically approved by the Goodyear Tire and Rubber Company.

*SEE PAGE 164 ON LUBRICANTS.

REMOVABLE FLANGE RIMS DEMOUNTING INSTRUCTIONS

SEE SAFETY
PRECAUTIONS -
PAGES
154-157

TG, VA, T, TH, JM RIMS DEMOUNTING

CAUTION: Always completely deflate tire by removing valve core from valve before attempting to remove the tire/rim assembly from the vehicle. Failure to do this may allow broken or damaged rim parts to fly apart with force sufficient to cause **SERIOUS PERSONAL INJURY OR DEATH.**

After completely deflating the rim, remove the assembly from the vehicle and place flat on floor with loose-flange side up and proceed in order with the following steps

SEE CAUTION BELOW



1. Work the goose-necked end of two #TO-799 tools between tire bead and flange about 5" apart. The babbit hammer may be used to force tool into prying position. (Starting Jan. 1984 tires will have 4" pry notch.)



2. Pry both tools outward and sideways through an arc of about 70°. Leave one tool in position and place the second tool about 5" beyond. Repeat the above operation in successive steps until the bead is completely broken loose.



3. After the bead is broken loose, press down on loose flange and tire sidewall away from rubber O ring and lock ring.
Mounting lube 20" bead diameter and over use water only.

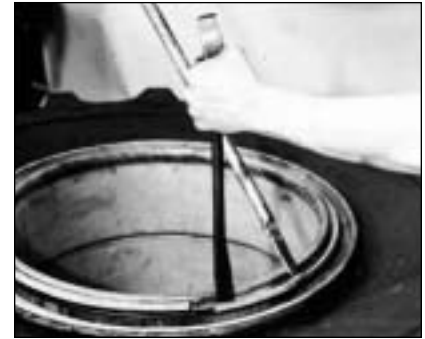

4. Pry the lock ring loose and remove. If necessary, hold the loose flange down with the hook end of tool #TO-799 to remove rubber O ring from groove in rim base.



5. Remove the side flange. Turn tire and rim over and break second bead by inserting both #TO-799 tools between tire bead and rim flange as in step 2. Repeat steps 1 and 2 until the tire is completely broken loose from the rim on the fixed flange side. Lift rim base out of tire.

CAUTION: Do not remove inflated tire mounted on a multipiece rim from a vehicle while the tire is inflated. Always exhaust all air pressure by removing the valve core and running a wire through the valve to make sure it is clear before loosening the lug bolts. This will prevent any damaged rim parts from being explosively released which could cause **Serious Personal Injury or Death.**

Tire gauges
Dill tire gauges
Extra Low Pressure, No. 7229 1 to 16 lbs. (1/2 lb. units) Low Pressure Gauge, No. 7213
4 to 50 lbs. (one lb. units)
Schrader tire gauges
Extra Low Pressure, No. 7750L 0 to 20 lbs. (1 lb. units) Low Pressure Gauge, No. 7750T
0 to 50 lbs. (one lb. units)

Mounting instructions fro 30" bead dia.
Terra-tire on tractor tire rim See Farm
Tire Handbook #862-905-508.

TIRE MOUNTING LUBRICANTS

USE ONLY THIN VEGETABLE OIL SOAP SOLUTION OR WATER. It has been brought to our attention that many non-approved mounting solutions are being used in the field. In some cases, these non-approved lubricants have been the direct cause of premature tire failure. Not only is the customer losing the service of the tires, but Goodyear also loses because many times the customer unjustly feels that the tire is at fault.

TYPE RIM	APPROVED LUBRICANT
Drop center	Thin solution of vegetable oil soap in water
Flat based multi-piece (20 bead dia & over)	Water only* Use sleeve or motorcycle tube placed between rim flange and tire bead to aid in sealing beads while inflating

*The use of any other lubricant in the mounting operation of Terra-Tire[®] or Agriculture tires may cause rim slippage resulting in premature tire failure. Service conditions at high torque and low inflation require minimum lubricant. Under no circumstances should any thick lubricant be used to create a temporary air seal.

Valve requirements

TR 412, 413, 415 (SNAP-IN)

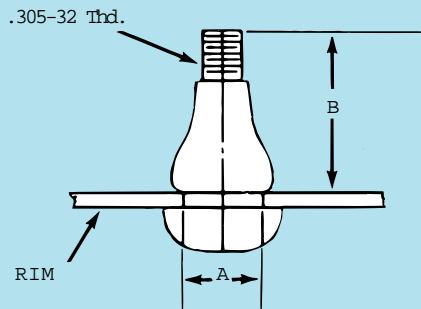

SNAP-IN VALVE
For Pressures Up To 65 PSI Cold

TR Valve No.	Valve Hole Dia. (A)	Valve Height (B)
412	.453	.88
413	.453	1.25
415	.625	1.25

TR 416, 416S (CLAMP-IN)

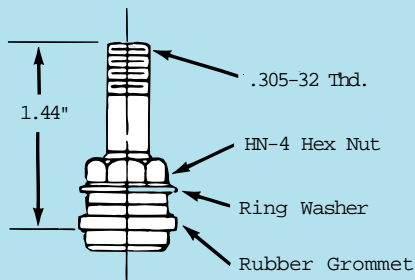

CLAMP IN VALVE FOR:
1. Pressures Greater Than 60 PSI
2. Liquid Fill, At Any Pressure

TR Valve No.	Valve Hole Dia. (A)	Ring Washer	Rubber Grommet
416	.625	RW -13	RG-39
416S	.453	RW -15	RG-54

TR-J670-03

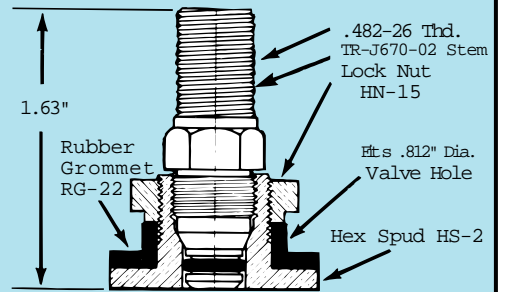

SPUD ASSEMBLY SP-2

Note: Adapter TR AD-1 required when using standard size air chuck and gauges required on TR-J670 valve only.

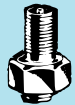

Valve Cap (TR-VC-4).

Adapter (TR-AD-1).

TR - 618A

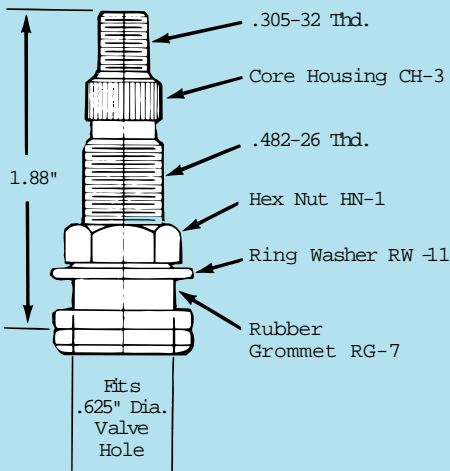

SUPER LARGE BORE VALVE

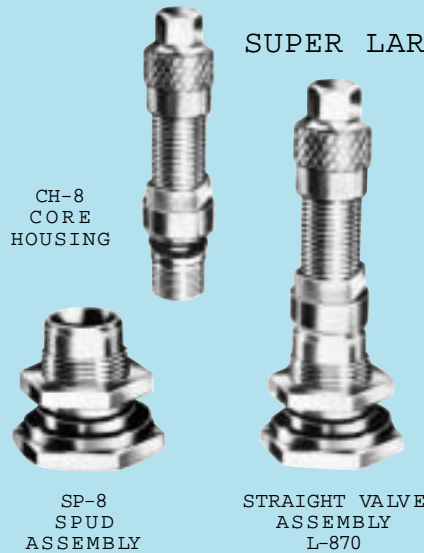

Super Large Bore Valve vs. Standard EM Valve DEFLATION COMPARISON

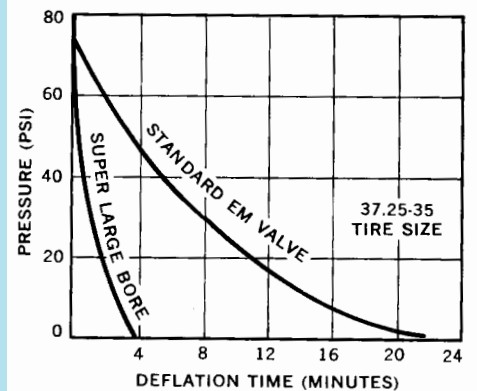

INFLATE ADAPTER (AIR OR LIQUID)



NOTES

NOTES