

ELECTRICAL SYSTEM

	Page Number
ALTERNATOR	
Adjusting The Alternator Belt	6-10
Alternator Output Test	6-8
Alternator Regulator Test	6-9
Assembly	6-13
Disassembly And Inspection	6-11
Rectifier Continuity (Diode) Test	6-12
Rectifier (Diode) Test	6-8
Removal And Installation	6-10
Rotor Continuity Test	6-12
Rotor Ground Test	6-12
Stator Continuity Test	6-11
Stator Ground Test	6-11
BATTERY	
Removal And Installation	6-5
Servicing The Battery	6-6
Using A Booster Battery	6-7
ELECTRICAL SYSTEM INFORMATION	
Description	6-4
Fuse Location	6-4
FRONT LIGHTS	
Removal And Installation	6-36
RELAY SWITCHES	
Location	6-37
STANDARD INSTRUMENT PANEL	
Removal And Installation	6-35
STARTER (DELCO REMY)	
Checking The Starter	6-14
Cleaning And Inspection	6-18
Disassembly And Assembly	6-16
Parts Identification	6-15
STARTER (DENSO)	
Assembly	6-28
Disassembly	6-20
Inspection And Repair	6-25
No Load Test	6-28
Parts Identification	6-19
Removal And Installation	6-18
TROUBLESHOOTING	
Chart	6-3

**ELECTRICAL
SYSTEM**

TIGHTEN ALL HARDWARE PER SIZE TO GRADE 5 TORQUE (SEE STANDARD TORQUE SPECIFICATIONS FOR BOLTS, SECTION 9) UNLESS OTHERWISE SPECIFIED.



bobcat[®]

CONTROLS HARNESS - 670766

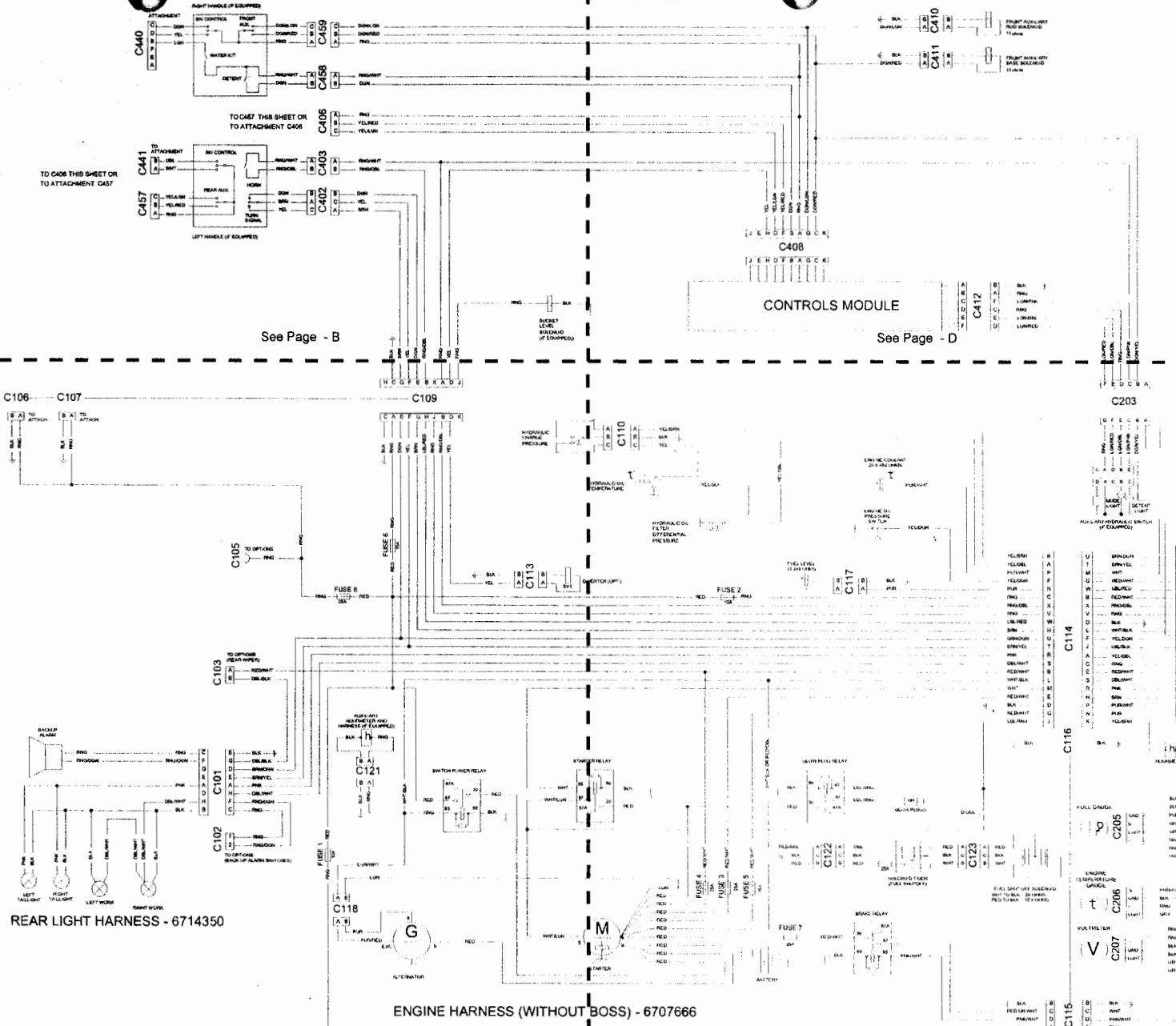

REAR LIGHT HARNESS - 6714350

ENGINE HARNESS (WITHOUT BOSS) - 6707666

CAB HARNESS (WITHOUT BOSS) - 6707665

MAINFRAME CONTROLLER HARNESS - 6706876 OR 6710313

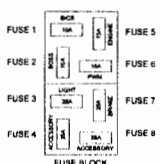

WIRES CONNECT BY LETTER ADDRESS CONNECTORS

SOME CONNECTOR BODIES NOT SHOWN FOR DRAWING CLARITY

RED = RED
 ORG = ORANGE
 BLK = BLACK
 LBL = LIGHT BLUE
 DBL = DARK BLUE
 LGN = LIGHT GREEN
 DGN = DARK GREEN
 YEL = YELLOW
 WHT = WHITE
 BRN = BROWN
 TAN = TAN
 PUR = PURPLE
 GRN = GRAY

753 WITHOUT BOSS - WIRING SCHEMATIC

S/N 512716001-24122
 (PRINTED OCTOBER 2000)
 MC2608

CONTROLS

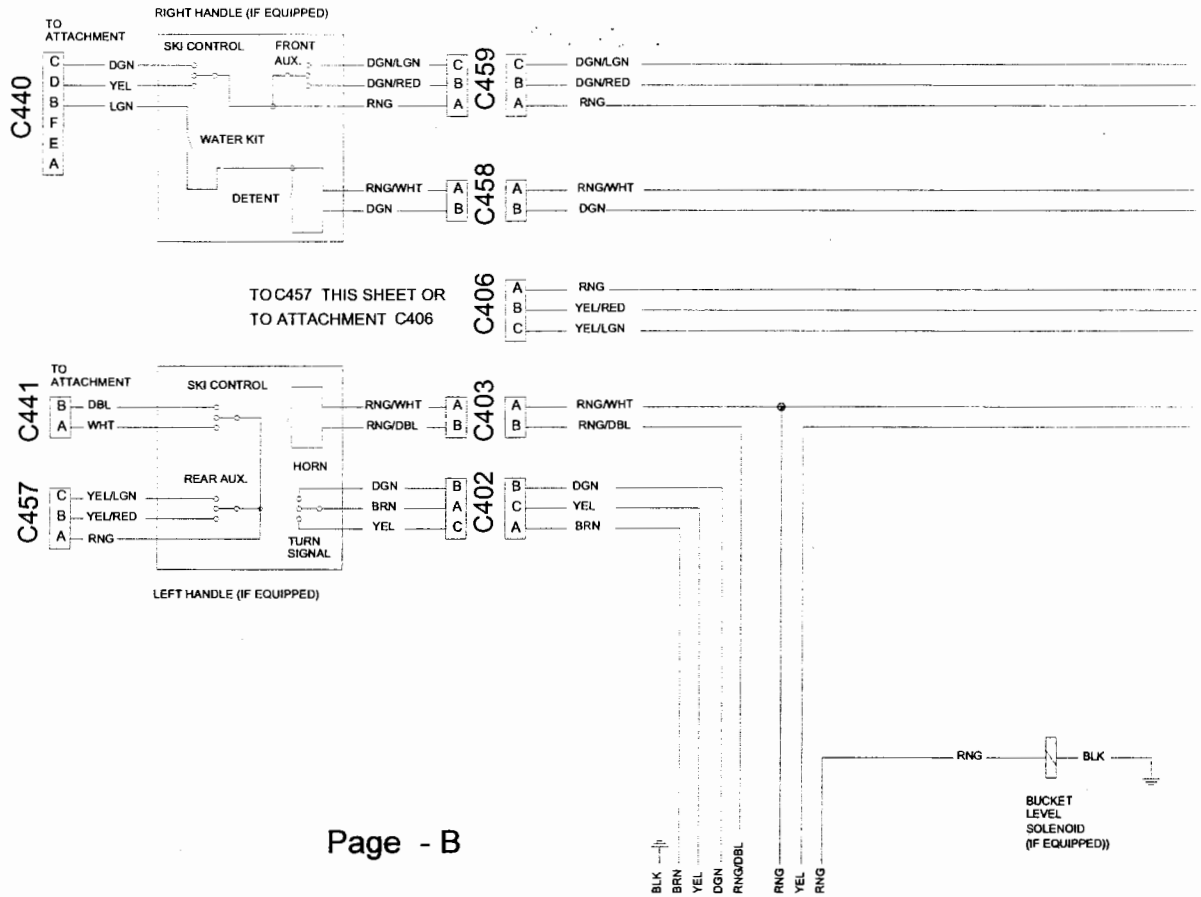

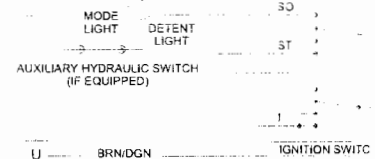
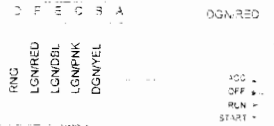

C114
C116

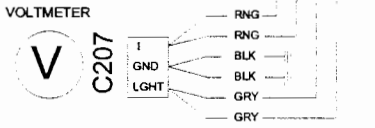
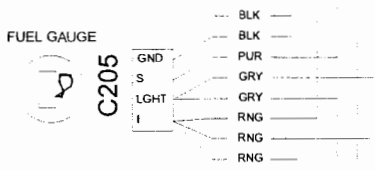
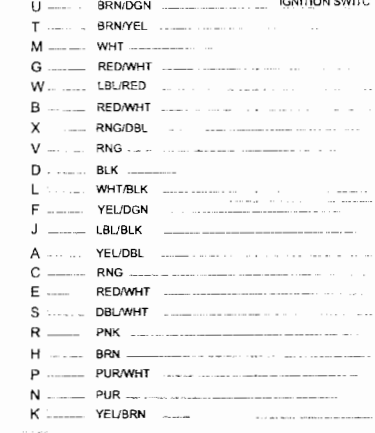

C115

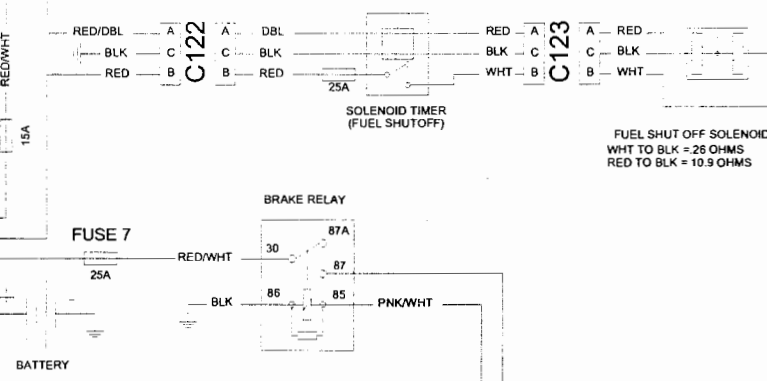
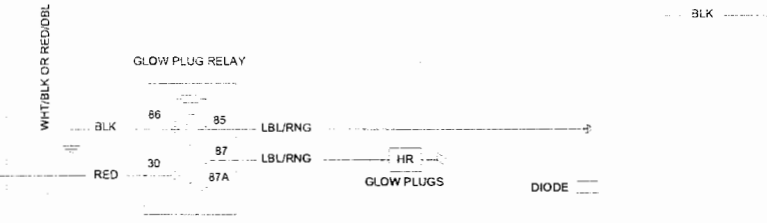
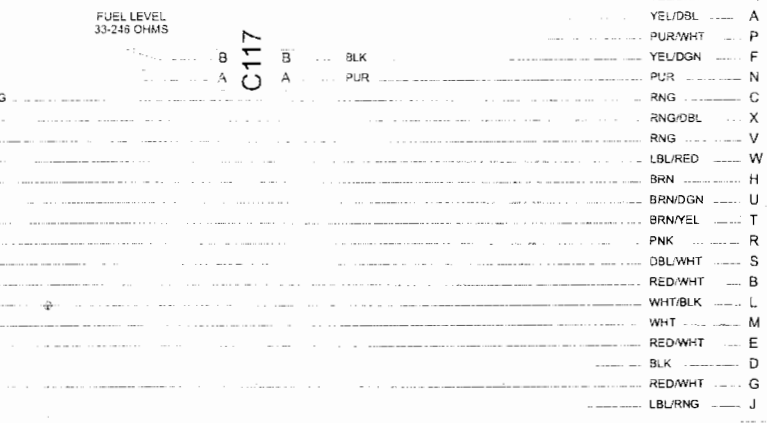
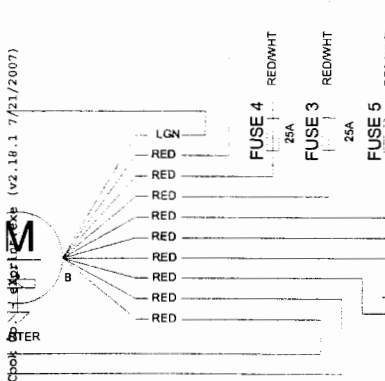
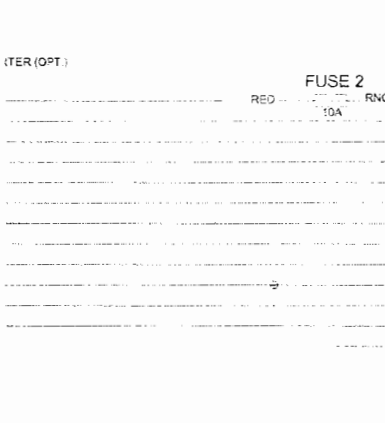
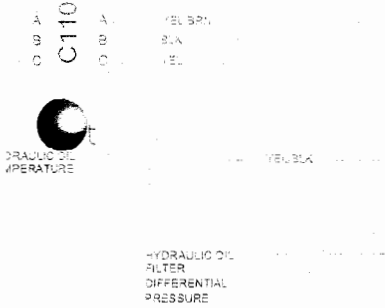

page 33 - 808MUL016/H1001 - 09/10/2007 10:20:17 - Printed by Ken Chok

DSS) - 6707666

WIRES CONNECT BY LETTER ACROSS CONNECTORS

SOME CONNECTOR BODIES NOT SHOWN FOR DRAWING CLARITY

RED = RED
RNG = ORANGE
BLK = BLACK
LBL = LIGHT BLUE
DBL = DARK BLUE
LGN = LIGHT GREEN
DGN = DARK GREEN
YEL = YELLOW
PNK = PINK
WHT = WHITE
BRN = BROWN
TAN = TAN
PUR = PURPLE
GRY = GREY

LS HARNESS - 6707676

Page 441 - B08M010167B1001 - 09/10/2007 10:20:17 - Printed by Ken Cook Co. - exprint.exe (v2.18.11 7/21/2007)

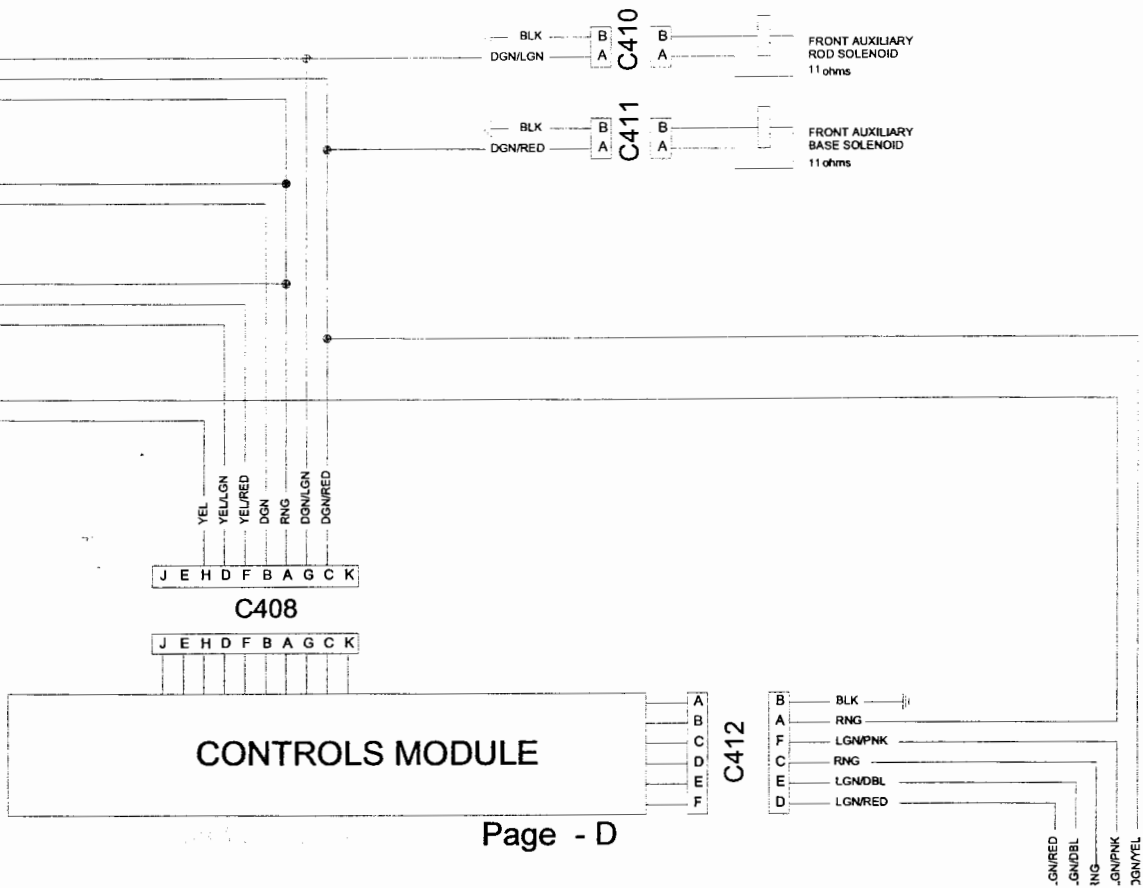

B'

CAB HARNESS (WITHOUT BOSS) - 6707665

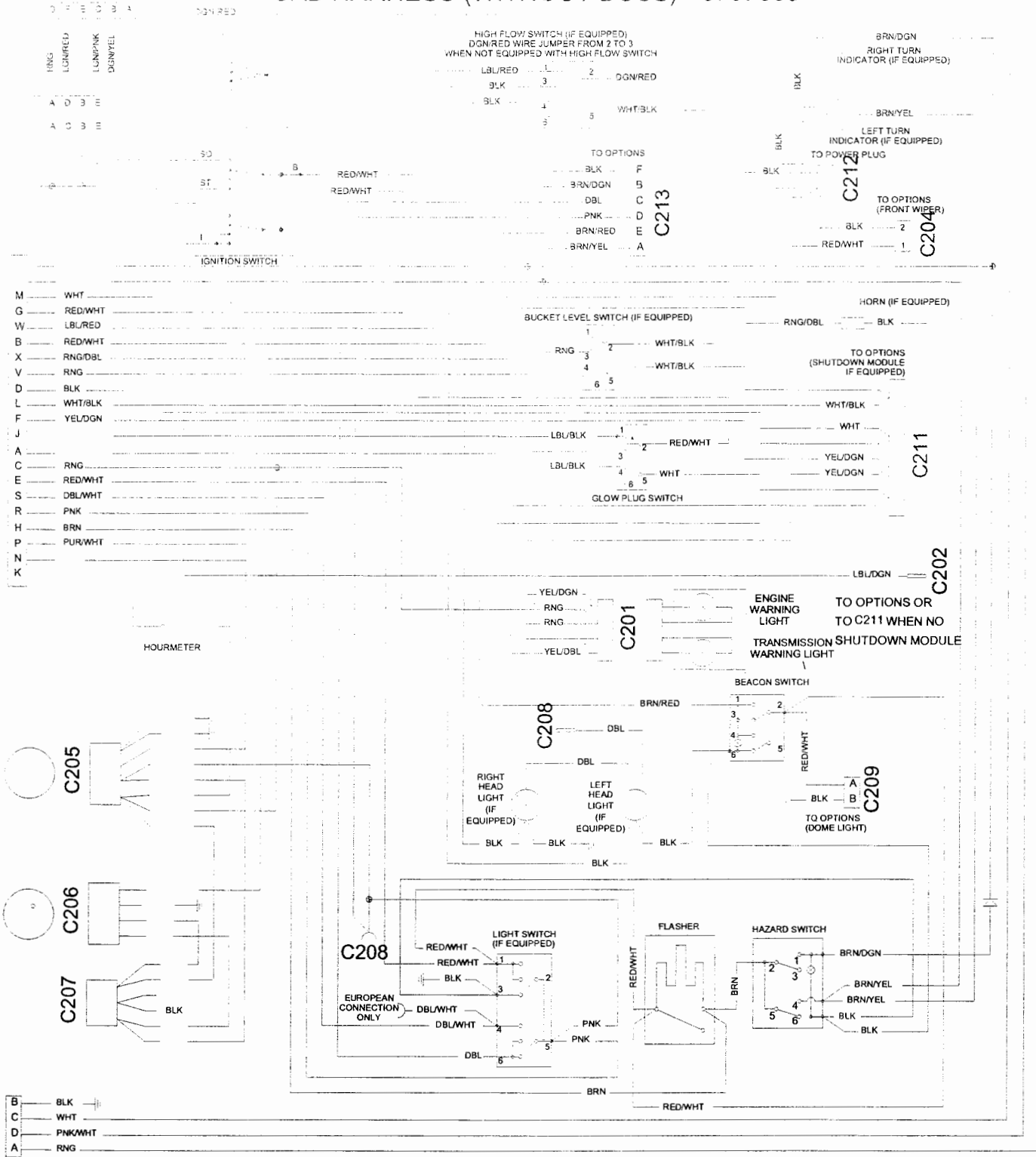

MC2608 (10-4-00)

Page 343 - BU08010167B1001 - 09/10/2007 10:20:17 - Printed by Ken Cook Co. - exprint.exe (v2.18.1 7/21/2007)

Page 143 | 09/10/2007 10:20:17 - Printed by Ken Cook Co. - eXprint.exe (v2.18.1 7/21/2007)

B1CS CONTROLLER HARNESS - 6706828 OR 6710312

C302

BICS CONTROLLER

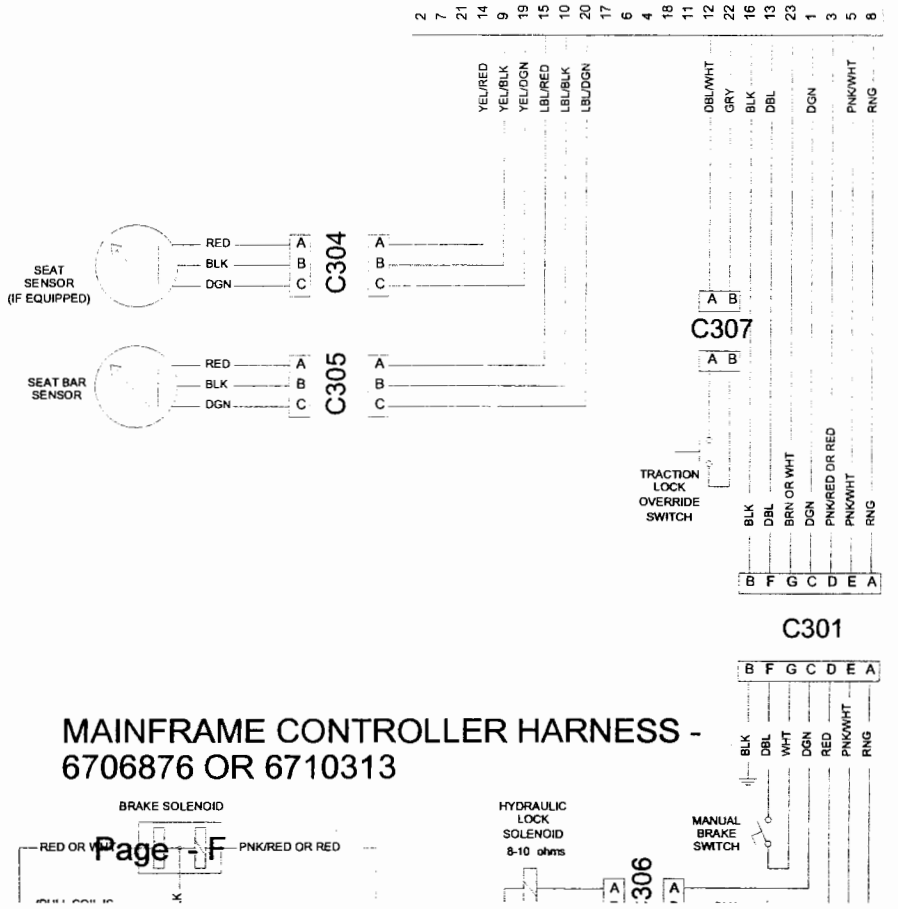

MAINFRAME CONTROLLER HARNESS - 6706876 OR 6710313

753 WITHOUT BOSS - WIRING SCHEMATIC
 WITH HIGH FLOW OPTION
 SKN 512716001-24122
 (PRINTED OCTOBER 2000)
 MC2609

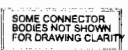
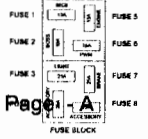
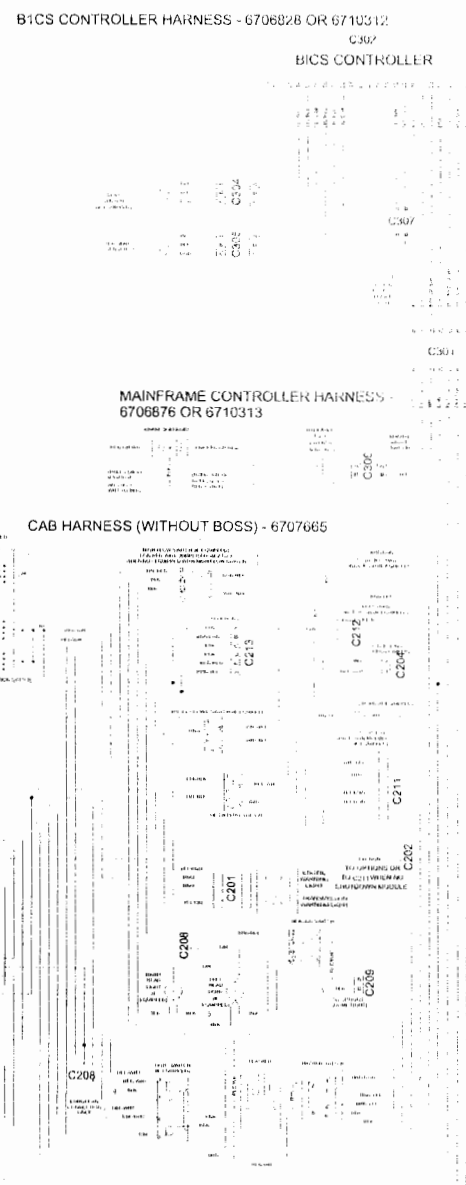
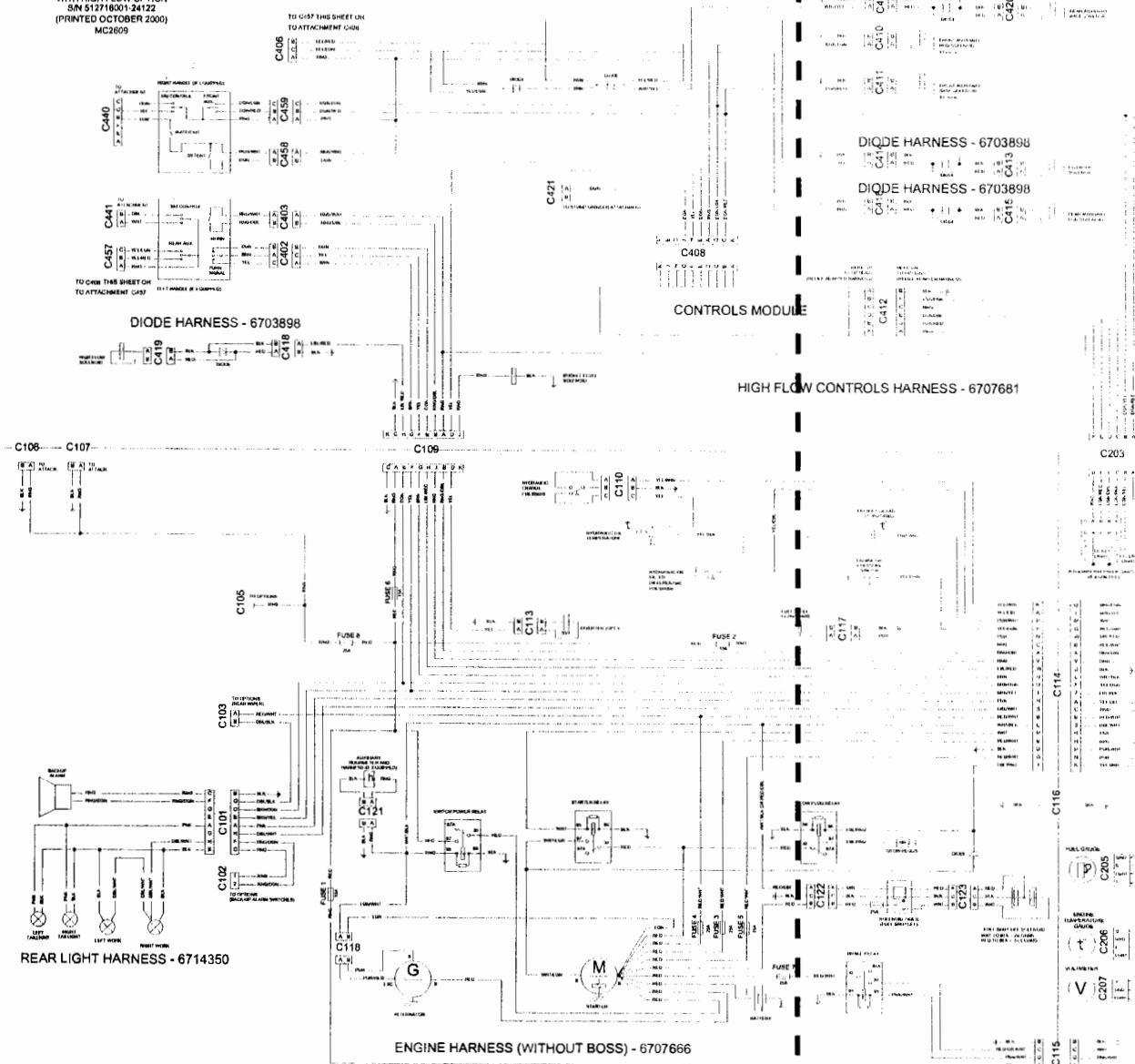

- RED = RED
- ORNG = ORANGE
- BLK = BLACK
- BLU = LIGHT BLUE
- DBL = DARK BLUE
- GRN = LIGHT GREEN
- DRN = DARK GREEN
- YEL = YELLOW
- WHT = WHITE
- PNK = PINK
- BRN = BROWN
- TRK = TAN
- GRY = GREY

See Page - A

See Page - B

DIODE HARNESS - 6703898

BICS CONTROLLER HARNESS - 6706828 OR 6710312

C302

BICS CONTROLLER

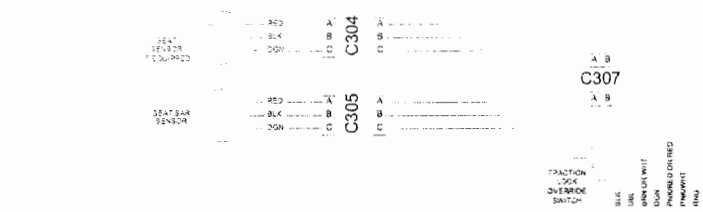
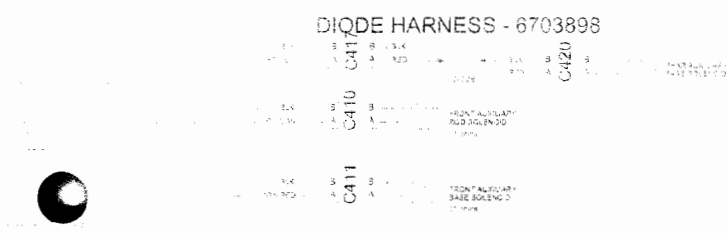

DIODE HARNESS - 6703898

DIODE HARNESS - 6703898

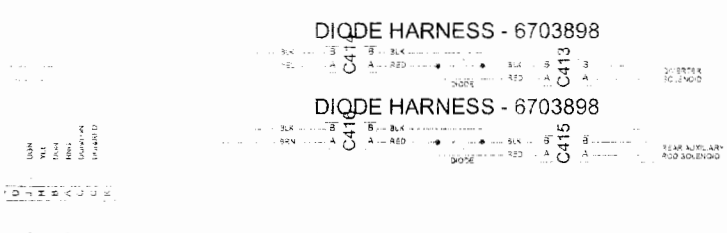

CONTROLS MODULE

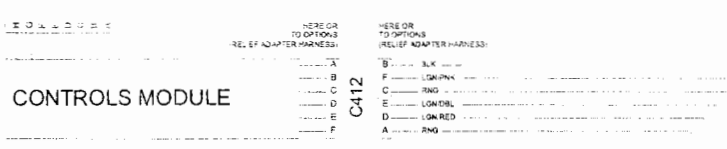

MAINFRAME CONTROLLER HARNESS - 6706876 OR 6710313



HIGH FLOW CONTROLS HARNESS - 6707681



CAB HARNESS (WITHOUT BOSS) - 6707665

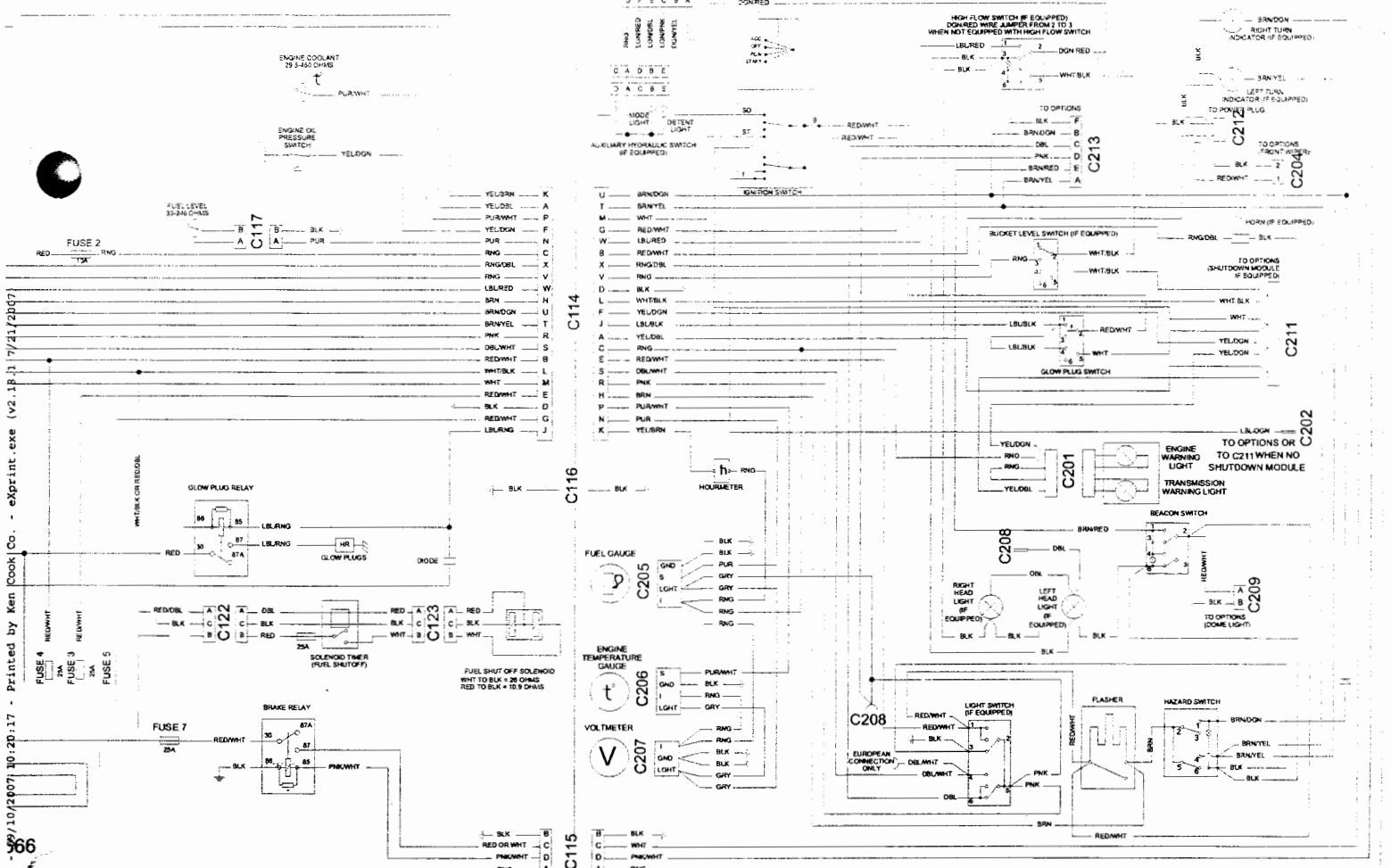

Printed by Ken Cook Co. - exprint.exe (v2.18) [7/21/2007] 10/20/2017 10:20:17 - 666



SOME CONNECTOR BODIES NOT SHOWN FOR DRAWING CLARITY

- RED = RED
- ORG = ORANGE
- BLK = BLACK
- LBL = LIGHT BLUE
- DBL = DARK BLUE
- LGN = LIGHT GREEN
- DMN = DARK GREEN
- YEL = YELLOW
- PNK = PINK
- WHT = WHITE
- BRN = BROWN
- TAN = TAN
- PUR = PURPLE
- GRY = GREY

753 BOSS - WIRING SCHEMATIC
 SN 51271801-24122
 (PRINTED OCTOBER 2000)
 MC2610

CONTROLS HARNESS - 6707676

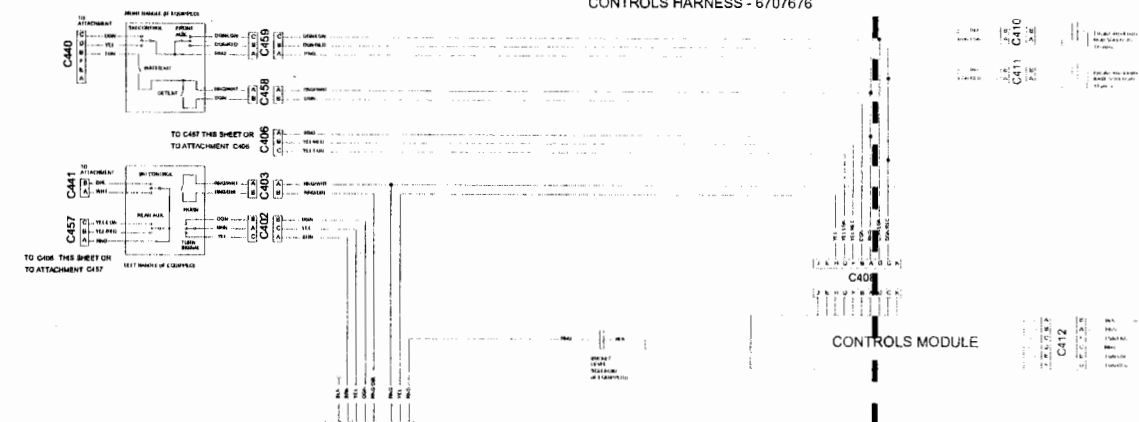

CONTROLS MODULE

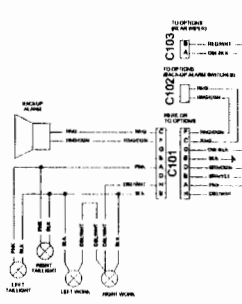
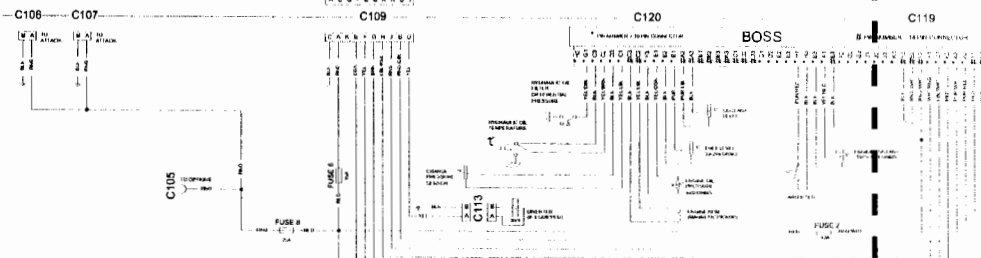

REAR LIGHT HARNESS - 6714350

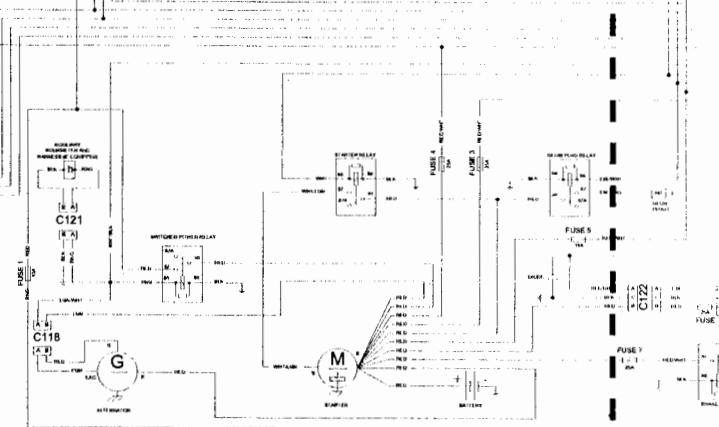

ENGINE HARNESS (BOSS) - 6707668

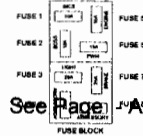

See Page - A

WIRES CONNECT BY LETTER ACROSS CONNECTORS

SOME CONNECTOR SIZES NOT SHOWN FOR DRAWING CLARITY

- RED = RED
- ORNG = ORANGE
- BLK = BLACK
- LBL = LIGHT BLUE
- DBL = DARK BLUE
- LGN = LIGHT GREEN
- DBK = DARK GREEN
- YEL = YELLOW
- PRP = PINK
- BRN = BROWN
- TAN = TAN
- PUR = PURPLE
- GRY = GREY

B1CS CONTROLLER HARNESS - 6706826 OR 6710312

**C302
B1CS CONTROLLER**

MAINFRAME CONTROLLER HARNESS - 6706876 OR 6710313

CAB HARNESS (BOSS) - 6707671

See Page - B

S - 6707676

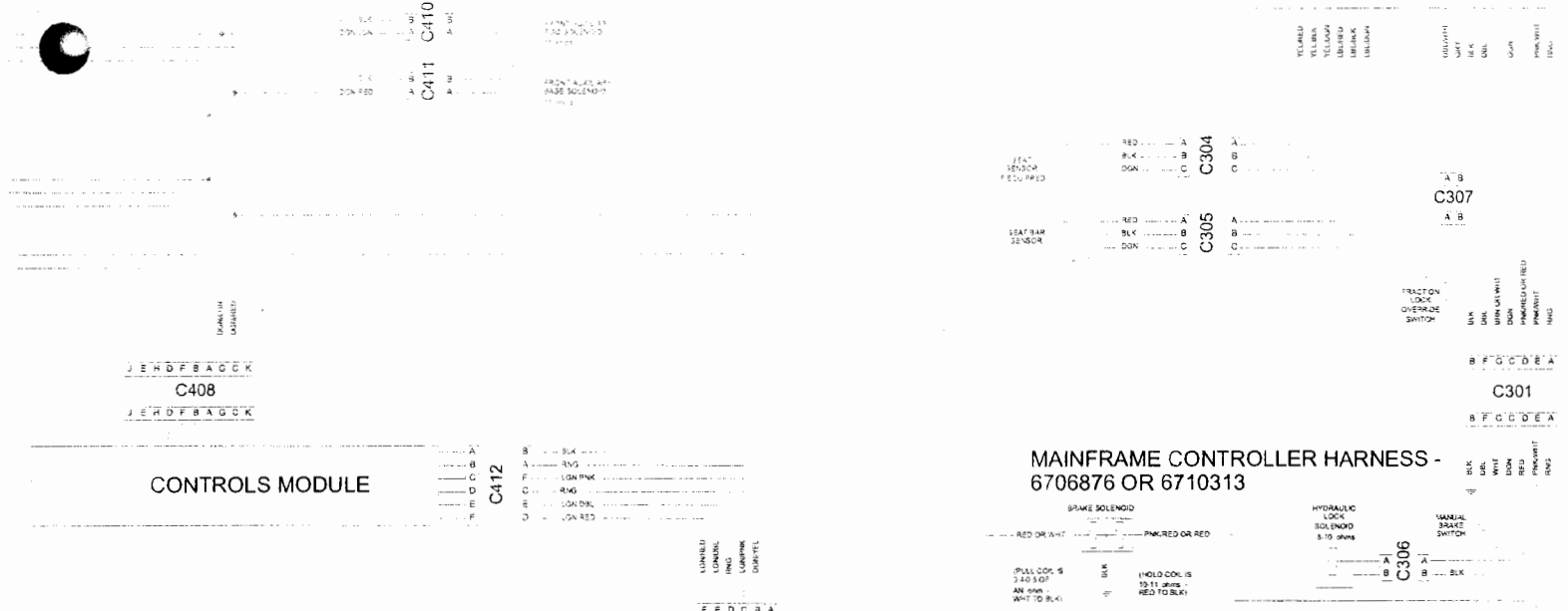

CONTROLS MODULE

MAINFRAME CONTROLLER HARNESS - 6706876 OR 6710313

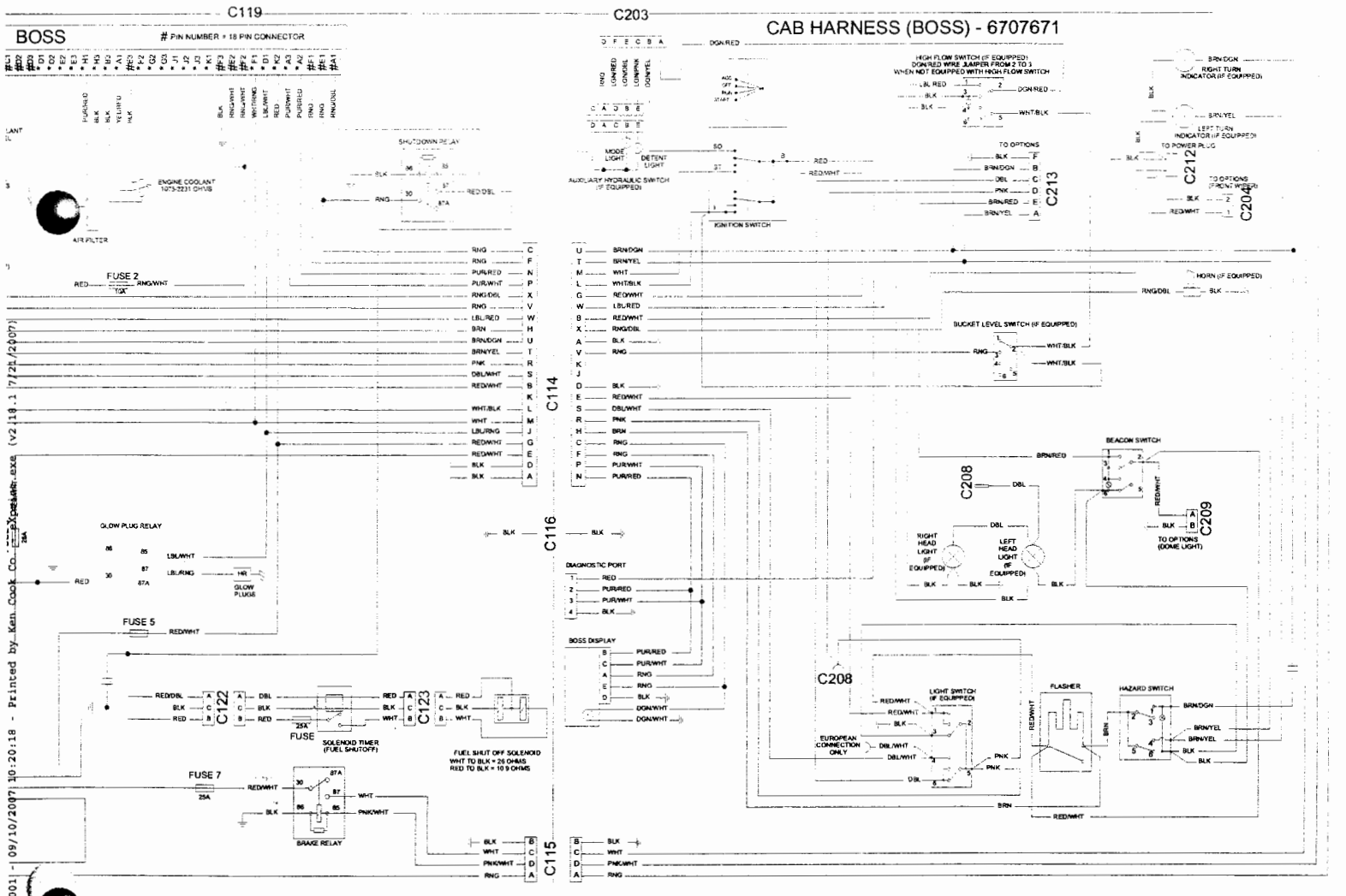

WIRES CONNECT BY LETTER ACROSS CONNECTORS

SOME CONNECTOR BODIES NOT SHOWN FOR DRAWING CLARITY

RED = RED
 RNG = ORANGE
 BLK = BLACK
 LBL = LIGHT BLUE
 DBL = DARK BLUE
 LGW = LIGHT GREEN
 DGN = DARK GREEN
 YEL = YELLOW
 PNK = PINK
 WHT = WHITE
 BRN = BROWN
 GRN = GREY

Page 357 - BUSB010167B1001 - 09/10/2007 10:20:18 - Printed by Ken Cook Co. - busb010167B1001.exe (v2.18.1.7/21/2007)

753 BOSS - WIRING SCHEMATIC
 WITH HIGH FLOW OPTION
 SIN 61716001-24122
 (PRINTED OCTOBER 2000)
 MC2611

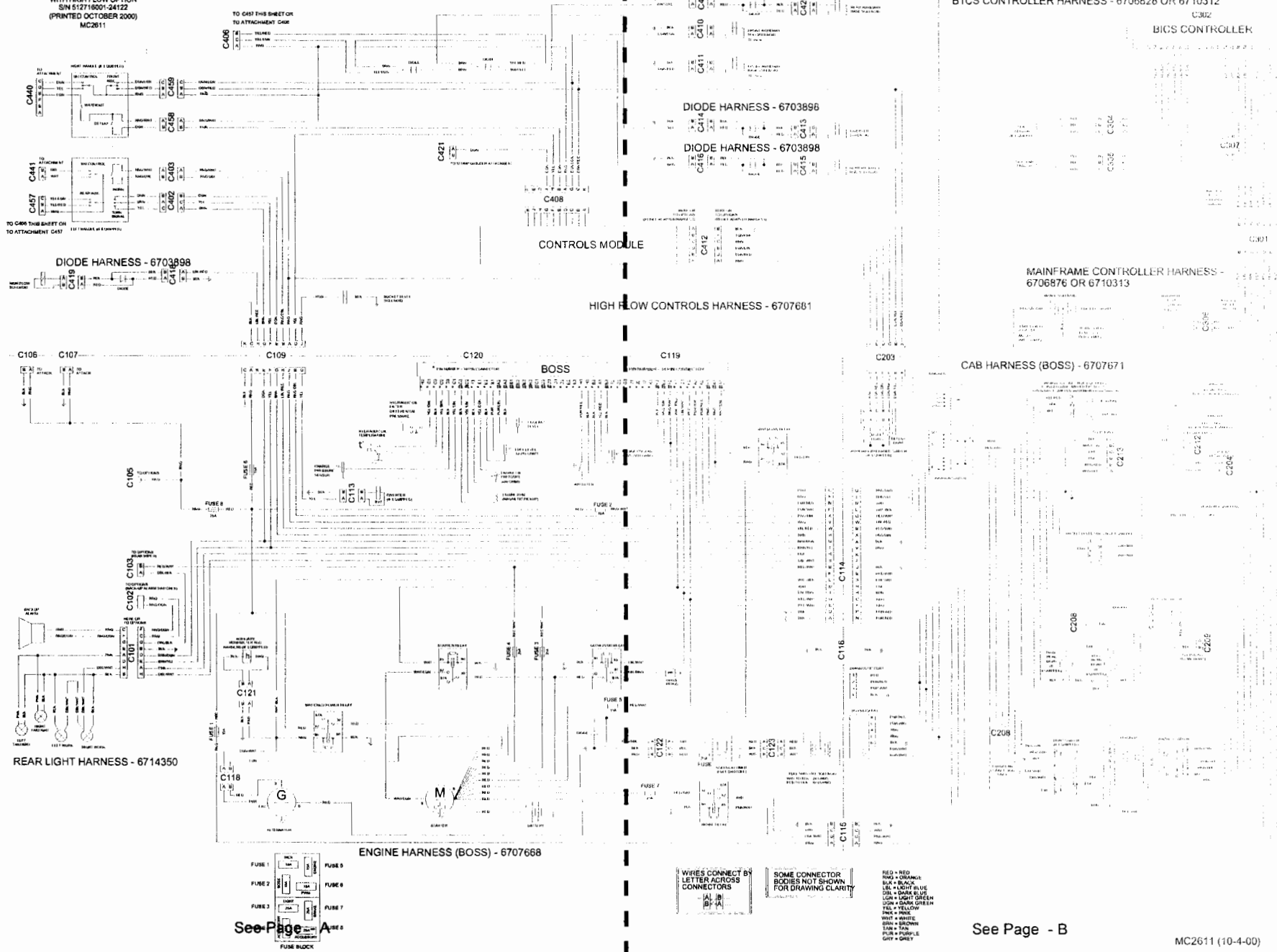

See Page A-4

WIRES CONNECT BY LETTER ACROSS CONNECTORS
 - A | B |
 - B | A |

SOME CONNECTOR BODIES NOT SHOWN FOR DRAWING CLARITY

RED = RED
 RING = ORANGE
 BLK = BLACK
 LBL = LIGHT BLUE
 DBL = DARK BLUE
 LGN = LIGHT GREEN
 DGM = DARK GREEN
 YEL = YELLOW
 PNC = PINK
 WHI = WHITE
 BRN = BROWN
 TAN = TAN
 PUR = PURPLE
 GRN = GREY

See Page - B

53 BOSS - WIRING SCHEMATIC

WITH HIGH FLOW OPTION
 S/N 512716001-24122
 (PRINTED OCTOBER 2000)
 MC2811

TO J437 THIS SHEET OR
 TO ATTACHMENT C439

C400
 B - BLK/RED
 C - YEL/BLK
 A - YEL



DIODE HARNESS - 6703898

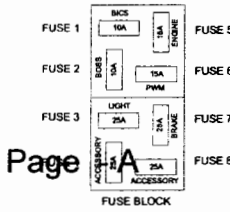
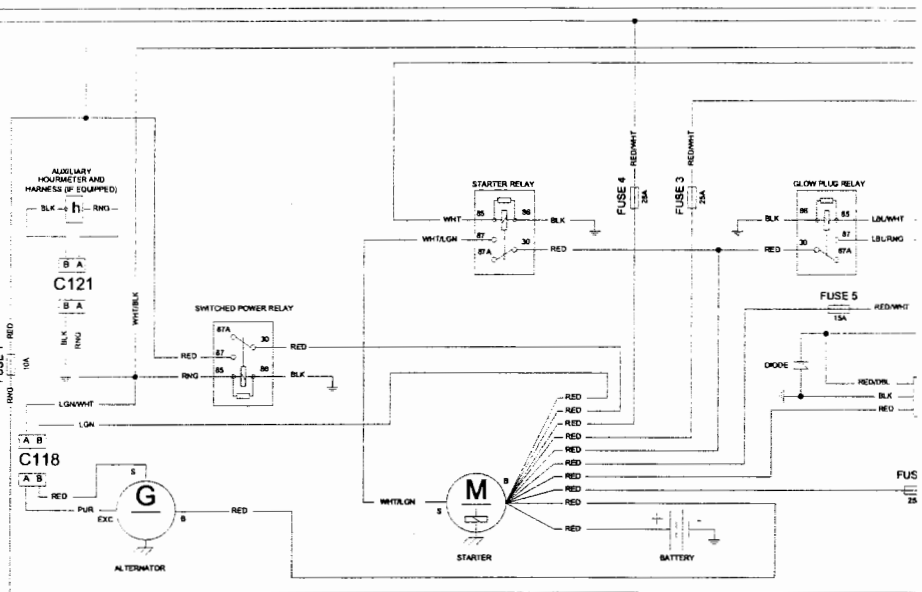
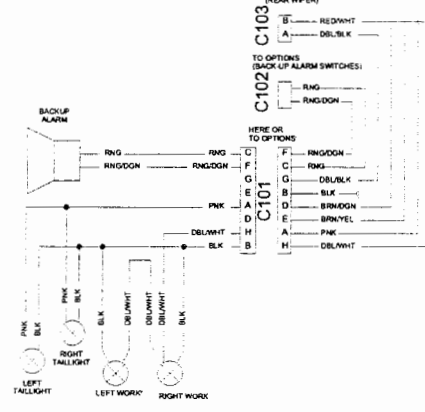
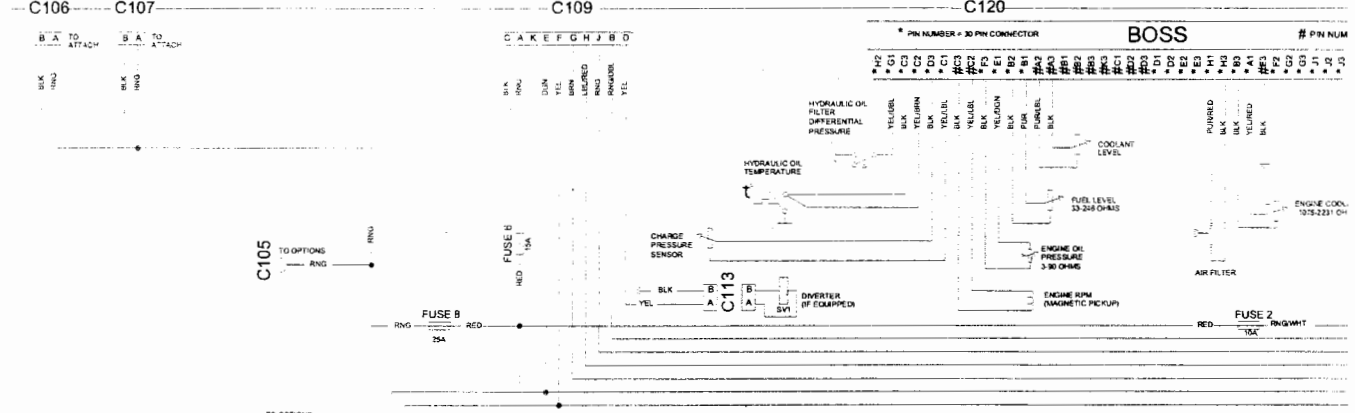
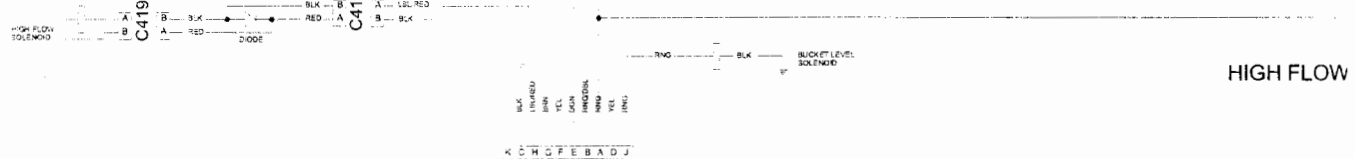

DIODE HARNESS - 6703898

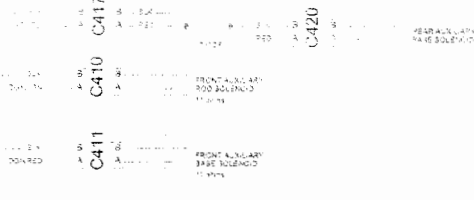

DIODE HARNESS - 6703898



DIODE HARNESS - 6703898

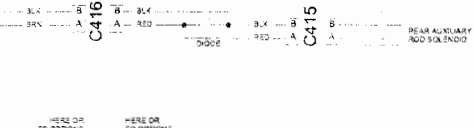

BICS CONTROLLER HARNESS - 6706828 OR 6710312

C302

BICS CONTROLLER



CONTROLS MODULE



MAINFRAME CONTROLLER HARNESS - 6706876 OR 6710313

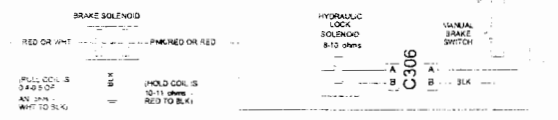

HIGH FLOW CONTROLS HARNESS - 6707681



CAB HARNESS (BOSS) - 6707671

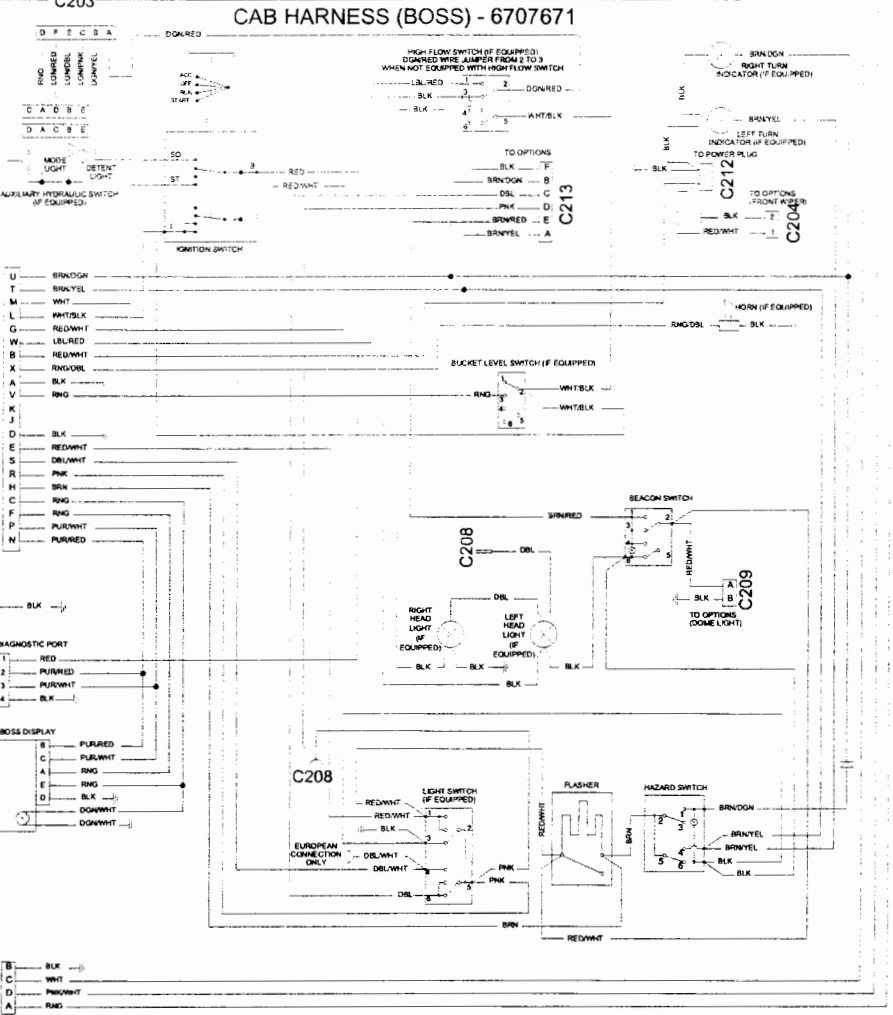

WIRES CONNECT BY LETTER ACROSS CONNECTORS

SOME CONNECTOR BODIES NOT SHOWN FOR DRAWING CLARITY

RED = RED
 RNG = ORANGE
 BLK = BLACK
 LBL = LIGHT BLUE
 DBL = DARK BLUE
 LGN = LIGHT GREEN
 DGRN = DARK GREEN
 YEL = YELLOW
 PNK = PINK
 WHT = WHITE
 BRN = BROWN
 PUR = PURPLE
 GRY = GREY

753 WITHOUT BOSS - WIRING SCHEMATIC
 SN 812734123-27872
 (PRINTED OCTOBER 2000)
 MC2612

CONTROLS HARNESS - 6710365

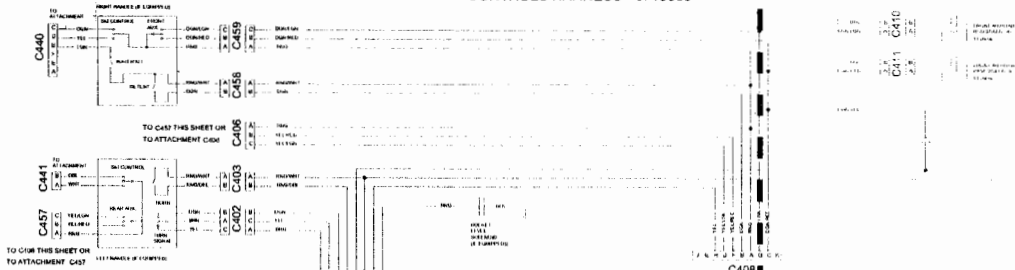

CONTROLS MODULE - 6671669

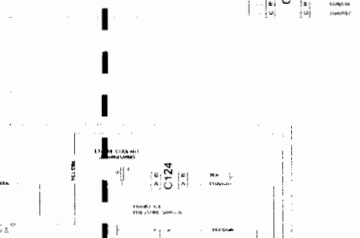

B1CS CONTROLLER HARNESS - 6710312
 C302

B1CS CONTROLLER

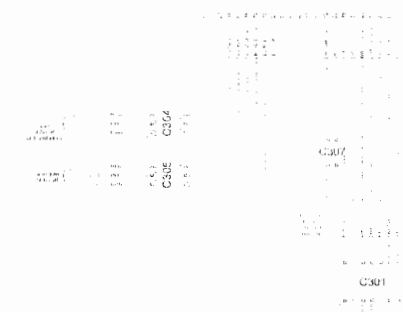

MAINFRAME CONTROLLER HARNESS - 6710313



CAB HARNESS (WITHOUT BOSS) - 6707665

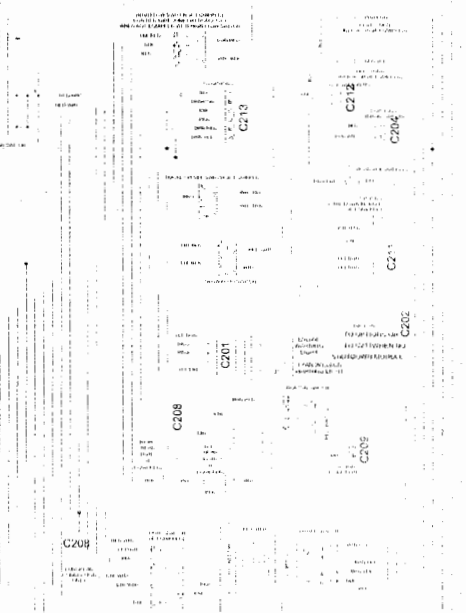

C106 C107

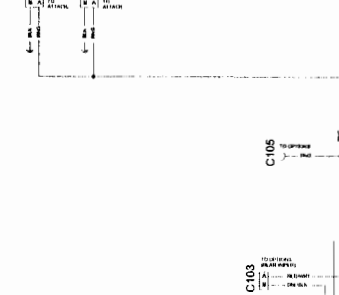

REAR LIGHT HARNESS - 6714350

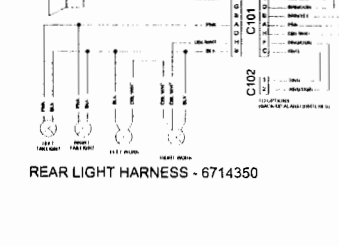

ENGINE HARNESS (WITHOUT BOSS) - 6709894



See Page - A

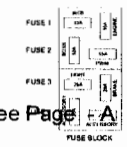

WIRES CONNECT BY LETTER ACROSS CONNECTORS

SOME CONNECTOR BODIES NOT SHOWN FOR DRAWING CLARITY

RED + RED
 BLUE + BLUE
 GREEN + GREEN
 YELLOW + YELLOW
 PURP + PURP
 BROWN + BROWN
 TAN + TAN
 PURP + PURPLE
 GRAY + GRAY

See Page - B

MC2612 (10-4-00)

CONTROLS HARNESS - 6710365

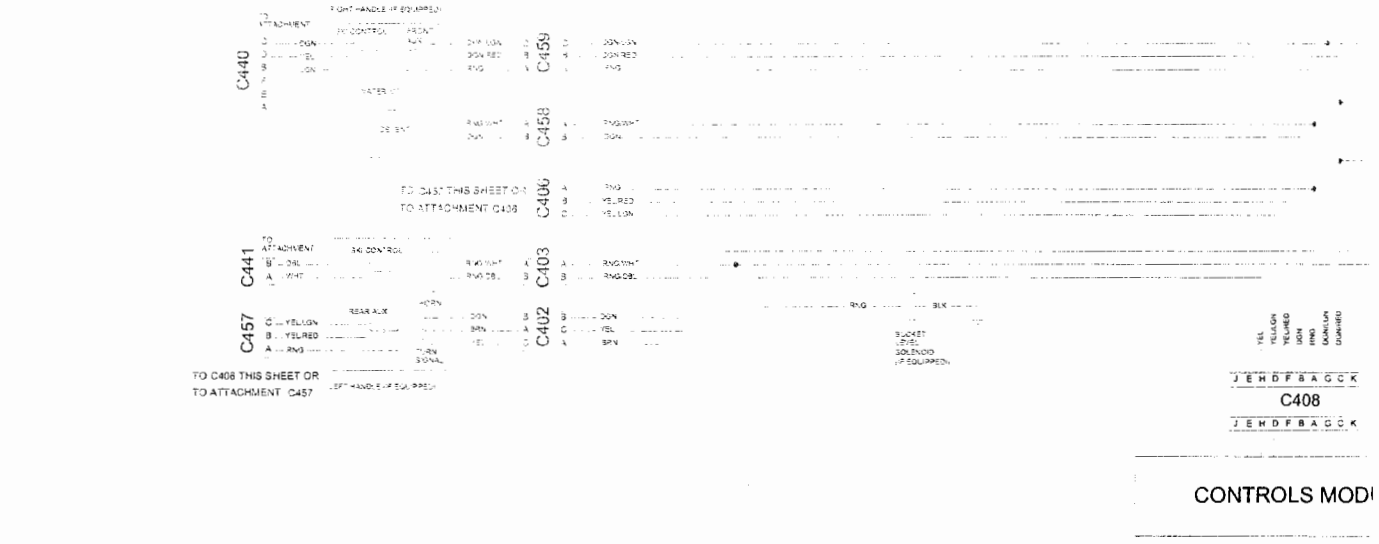

CONTROLS MOD

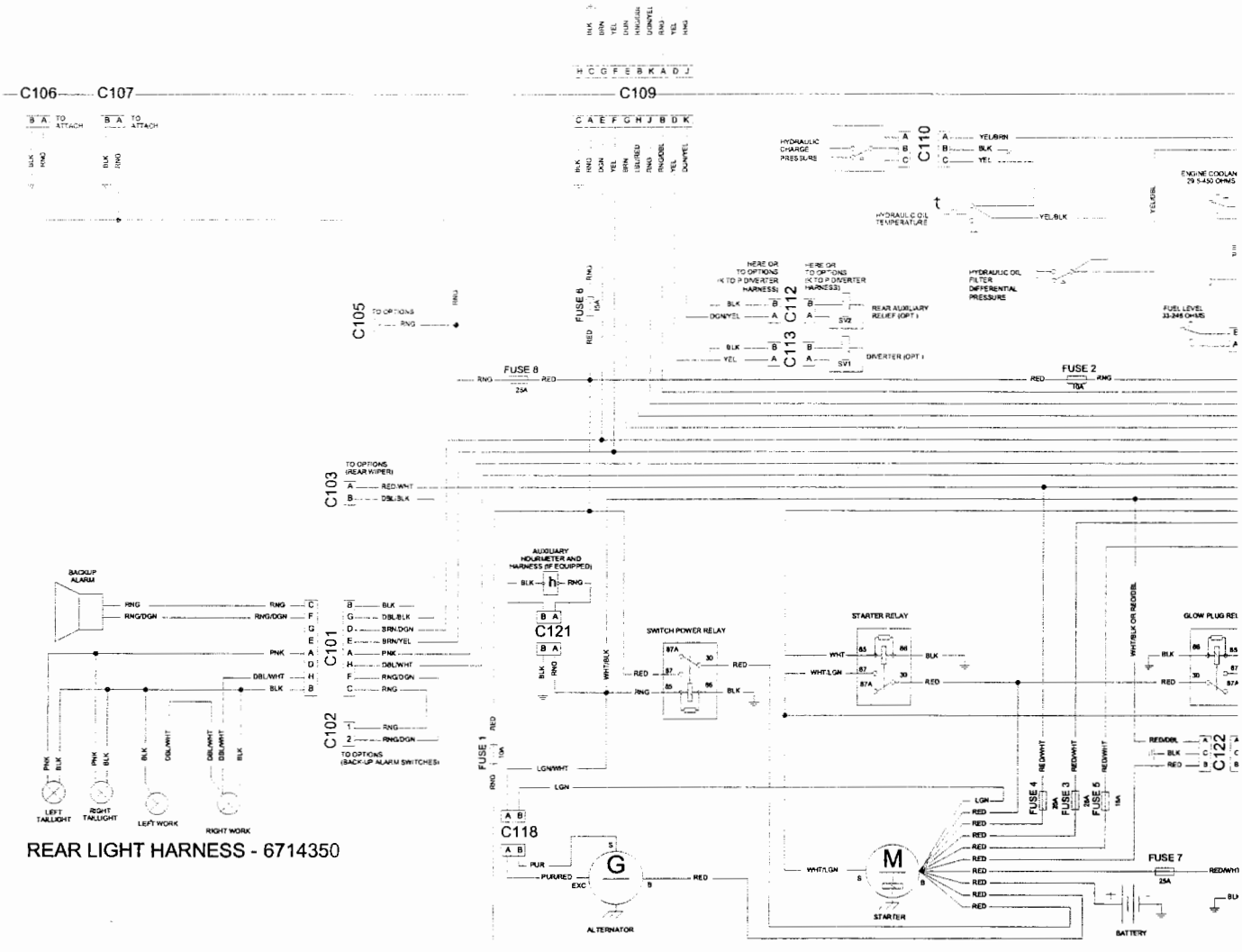

REAR LIGHT HARNESS - 6714350

ENGINE HARNESS (WITHOUT BOSS) - 6709894

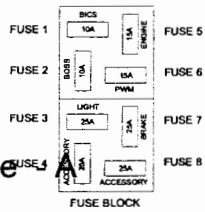

Page 367 - 6080010106751001 - 09/10/2007 10:20:19 - Printed by Ken Cook Co. - exprint.exe (v2.18.1 7/21/2007)

6710365

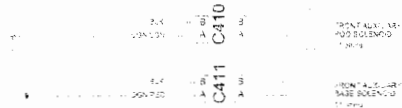

C307

C306

C301

CONTROLS MODULE - 6671669

MAINFRAME CONTROLLER HARNESS - 6710313

CAB HARNESS (WITHOUT BOSS) - 6707665

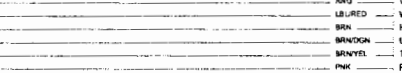

- RED = RED
- RNG = ORANGE
- BLK = BLACK
- LBL = LIGHT BLUE
- DBL = DARK BLUE
- LGN = LIGHT GREEN
- DGN = DARK GREEN
- YEL = YELLOW
- PNK = PINK
- WHT = WHITE
- BRN = BROWN
- TAN = TAN
- PUR = PURPLE
- GRY = GREY

WIRES CONNECT BY LETTER ACROSS CONNECTORS

A	B
B	A

SOME CONNECTOR BODIES NOT SHOWN FOR DRAWING CLARITY

Page 369 - BOBM010167B1001 - 09/10/P407 (10-28-19 - Printed by Kern Cook Co. - e-print.exe (v2.11.1) (1/21/2007)

753 WITHOUT BOSS - WIRING SCHEMATIC

WITH HIGH FLOW OPTION
 SN 512724123-27872
 (PRINTED OCTOBER 2000)
 MC2613

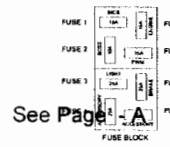
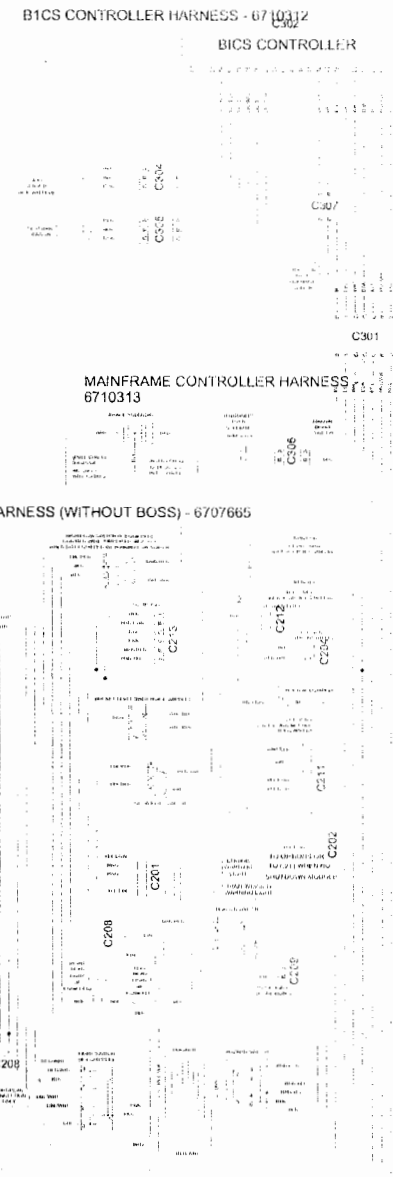
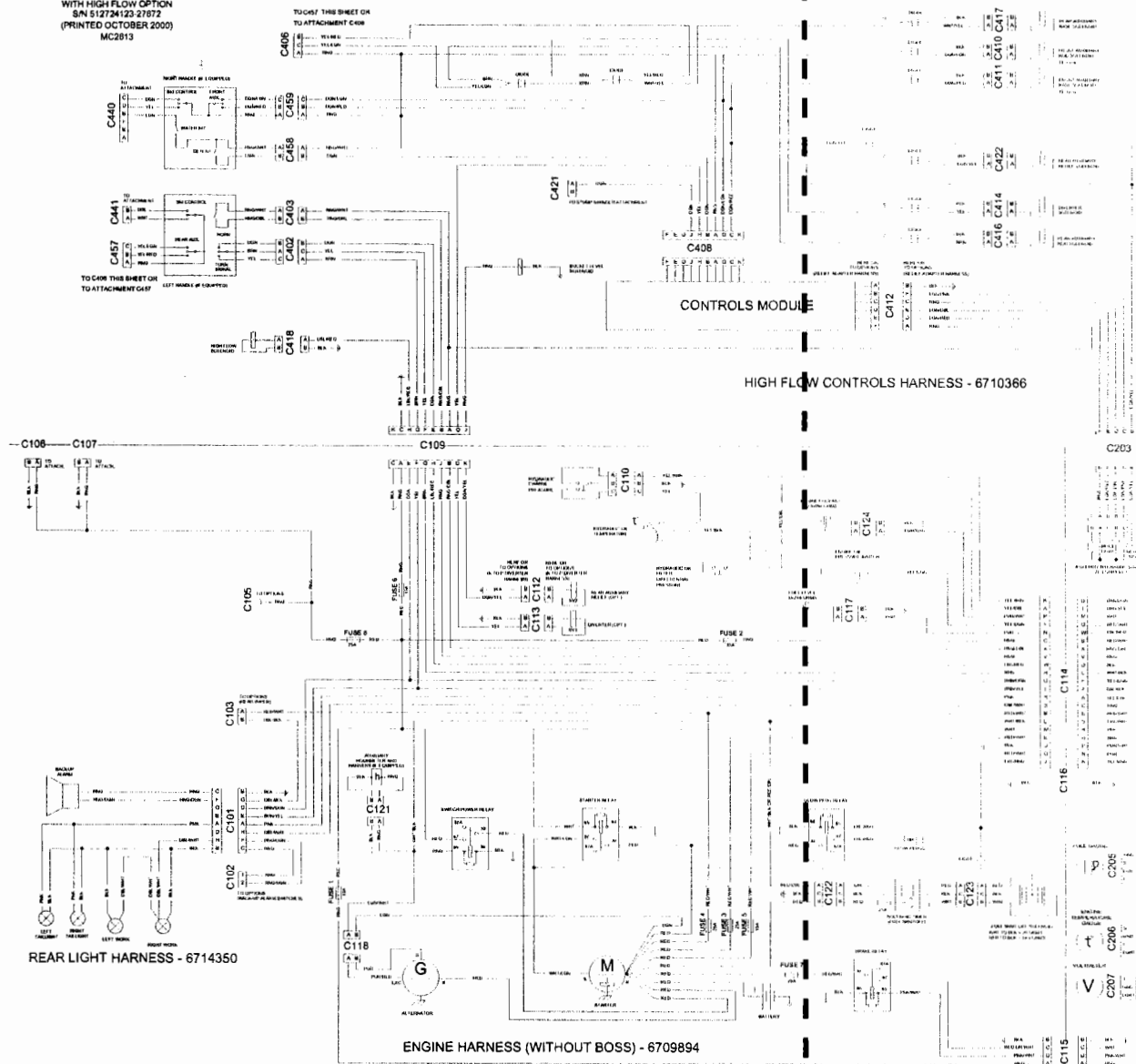

WIRES CONNECT BY LETTER ADDRESS CONNECTORS

SOME CONNECTOR BODIES NOT SHOWN FOR DRAWING CLARITY

- RED = RED
- ORNG = ORANGE
- BLK = BLACK
- BLU = LIGHT BLUE
- DBL = DARK BLUE
- GRN = GREEN
- DMN = DARK GREEN
- YEL = YELLOW
- WHT = WHITE
- PUR = PURPLE
- BRN = BROWN
- TAN = TAN
- PUR = PURPLE
- GRY = GREY

See Page - B

MC2613 (10-4-00)

C302

BICS CONTROLLER



MAINFRAME CONTROLLER HARNESS 6710313



HIGH FLOW CONTROLS HARNESS - 6710366

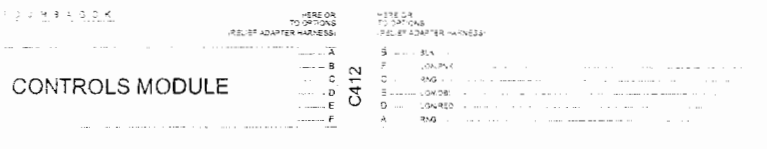

CAB HARNESS (WITHOUT BOSS) - 6707665

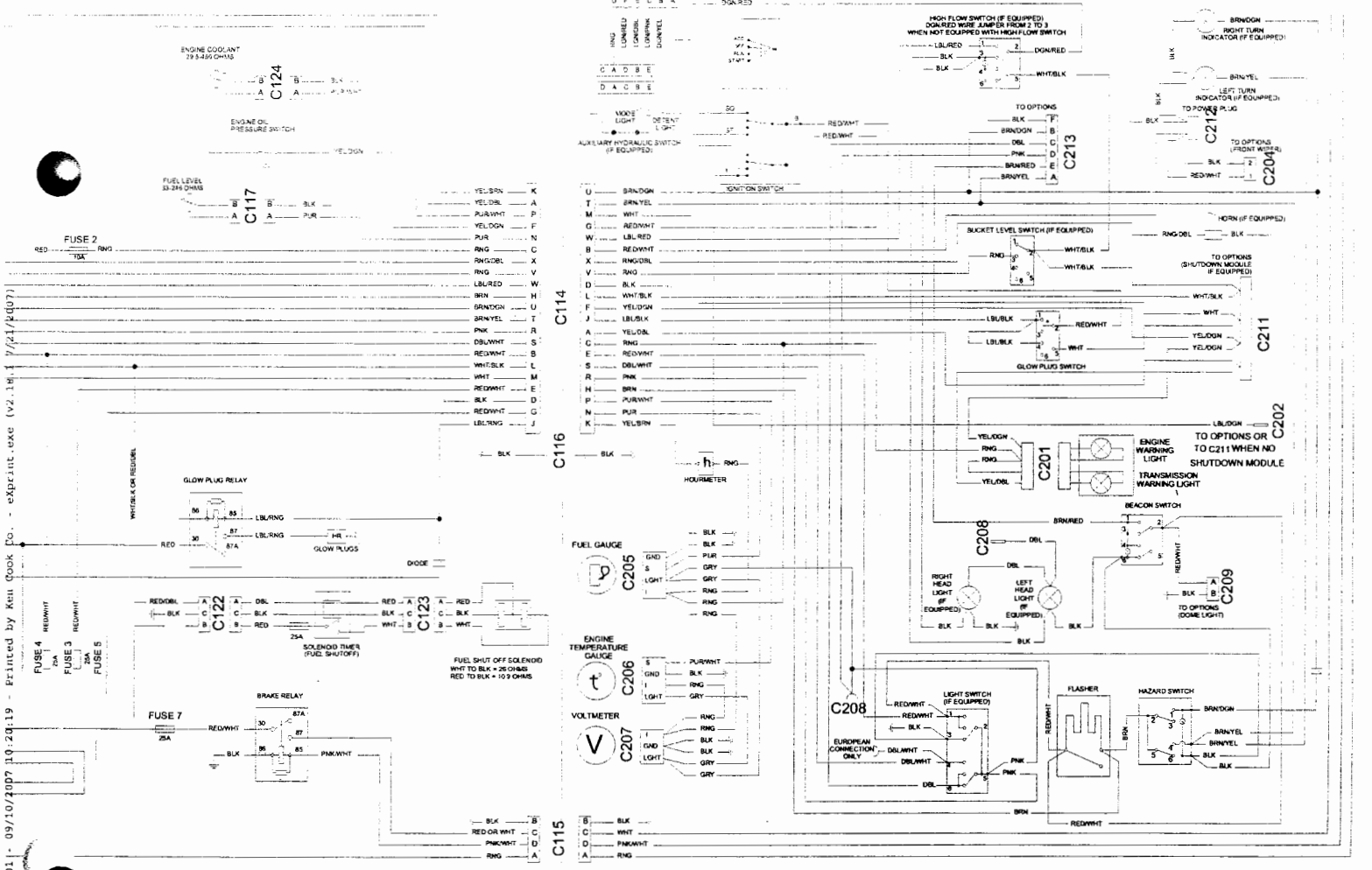

09/10/2007 10:20:19 - Printed by Ken Cook Co. - exprint.exe (v2.14.1 7/21/07)

WIRES CONNECT BY LETTER ACROSS CONNECTORS

SOME CONNECTOR BODIES NOT SHOWN FOR DRAWING CLARITY

RED = RED
 RNG = ORANGE
 BLK = BLACK
 LBL = LIGHT BLUE
 DBL = DARK BLUE
 LGN = LIGHT GREEN
 DGN = DARK GREEN
 YEL = YELLOW
 PNK = PINK
 WHT = WHITE
 BRN = BROWN
 TAN = TAN
 PUR = PURPLE
 GRY = GREY

753 BOSS - WIRING SCHEMATIC
 SN 512734123-27872
 (PRINTED OCTOBER 2000)
 MC2614

CONTROLS HARNESS - 6710365

B1CS CONTROLLER HARNESS - 6710312
 C302

B1CS CONTROLLER

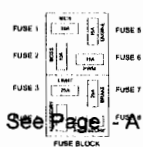
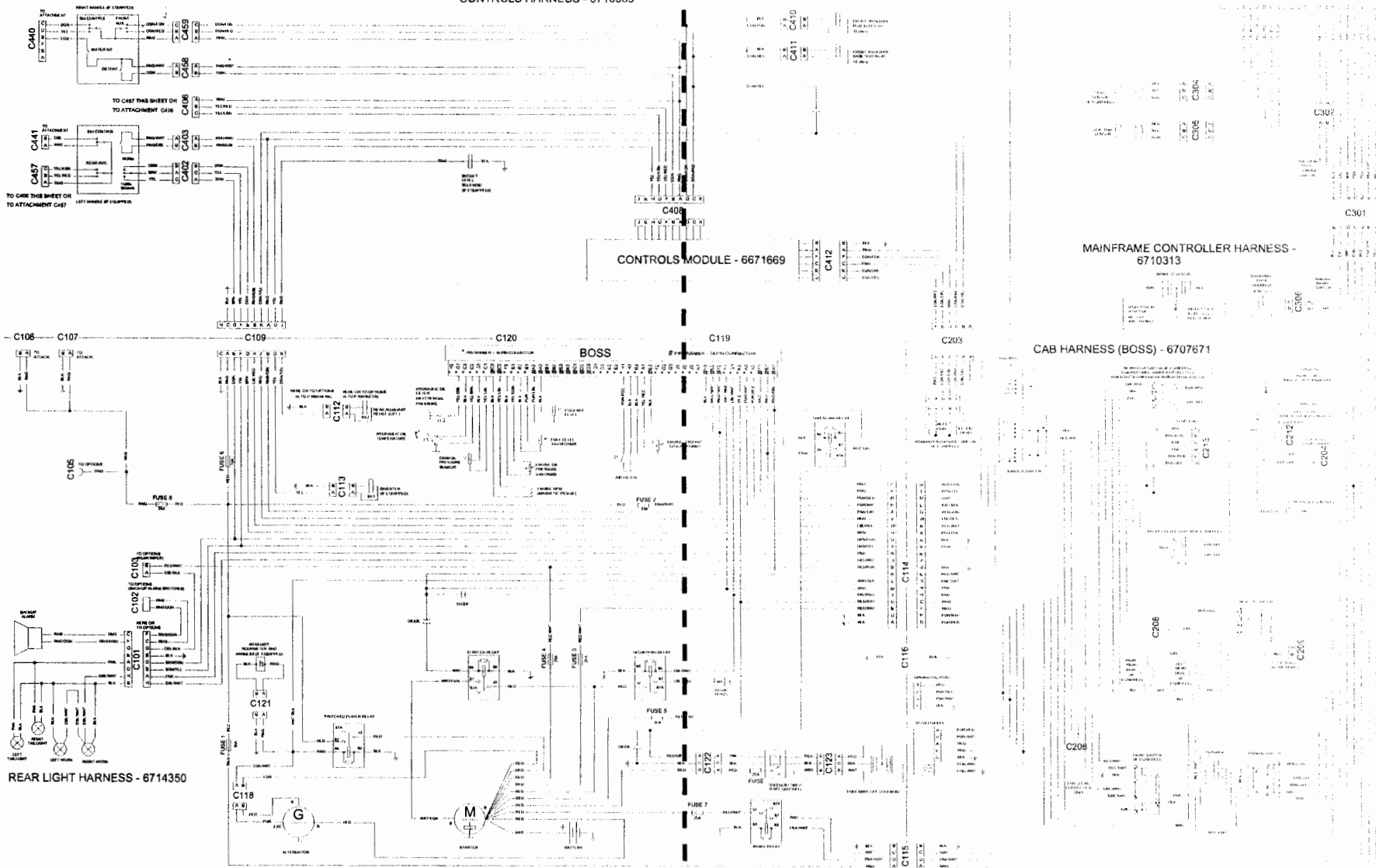

WIRES CONNECT BY LETTER ACROSS CONNECTORS (A-J) (B-JA)

SOME CONNECTOR BODIES NOT SHOWN FOR DRAWING CLARITY

- RED = RED
- ORNG = ORANGE
- BLK = BLACK
- LTBLU = LIGHT BLUE
- DBLU = DARK BLUE
- LGREN = LIGHT GREEN
- DBGREN = DARK GREEN
- YEL = YELLOW
- PUR = PURPLE
- WHT = WHITE
- BRN = BROWN
- PINK = PINK
- GRY = GRAY
- GRN = GREEN

See Page - B



TO SET THIS SHEET OR TO ATTACHMENT C408



CONTROLS MOL

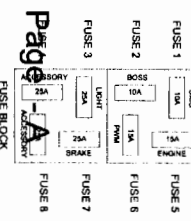
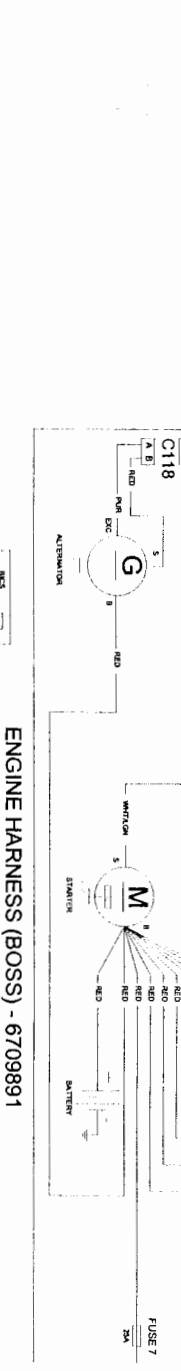
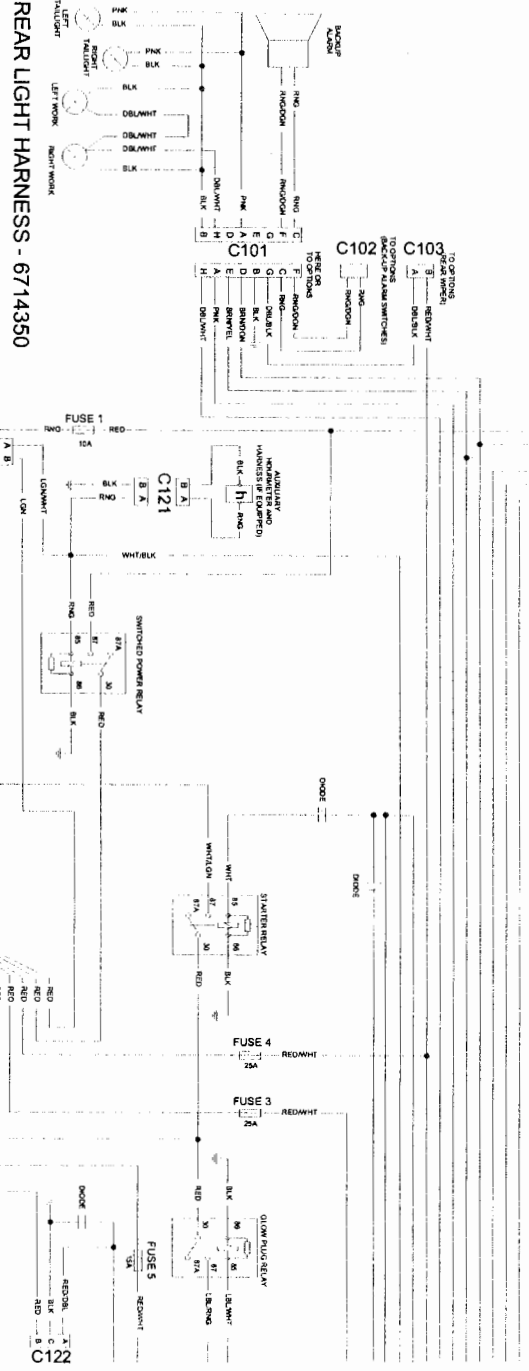
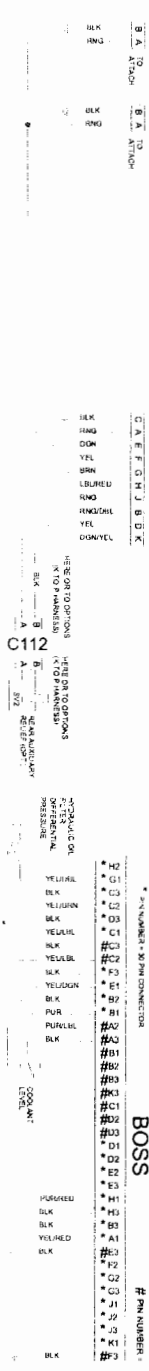

7	21	14	9	19	15	20	17	8	4	11	12	22	16	13	10	5	6
RELAY 1	RELAY 2	RELAY 3	RELAY 4	RELAY 5	RELAY 6	RELAY 7	RELAY 8	RELAY 9	RELAY 10	RELAY 11	RELAY 12	RELAY 13	RELAY 14	RELAY 15	RELAY 16	RELAY 17	RELAY 18

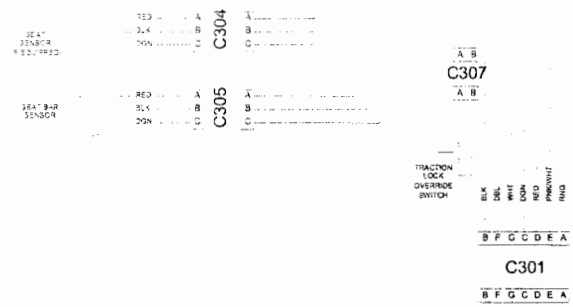

MAINFRAME CONTROLLER HARNESS - 6710313

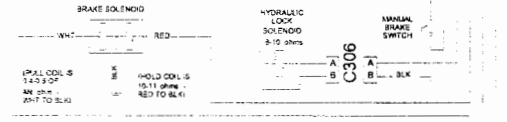

CONTROLS MODULE - 6671669

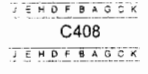

BOSS # PIN NUMBER = 18 PIN CONNECTOR

1	2	3	4	5	6	7	8	9	10	11	12	13	14	15	16	17	18
BLK	BLK	BLK	BLK	BLK	BLK	BLK	BLK	BLK	BLK	BLK	BLK	BLK	BLK	BLK	BLK	BLK	BLK

CAB HARNESS (BOSS) - 6707671

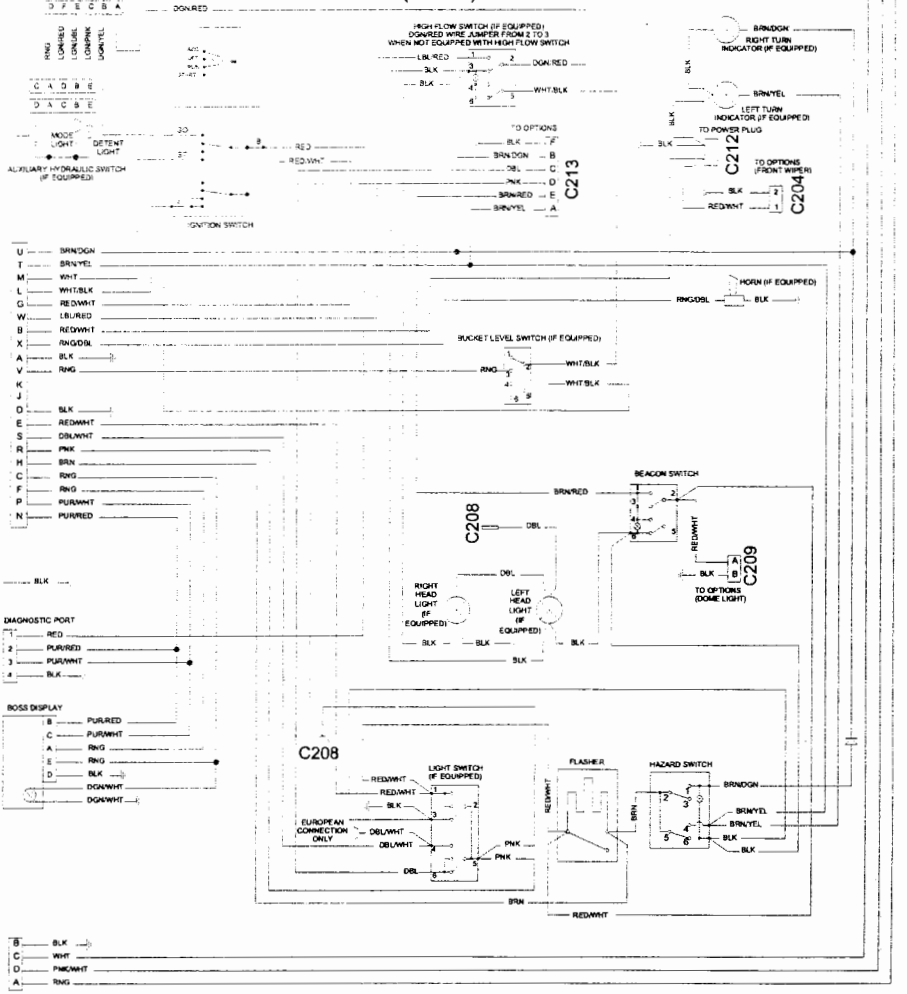

WIRES CONNECT BY LETTER ACROSS CONNECTORS

SOME CONNECTOR BODIES NOT SHOWN FOR DRAWING CLARITY

RED = RED
RNG = ORANGE
BLK = BLACK
LBL = LIGHT BLUE
DBL = DARK BLUE
LGN = LIGHT GREEN
DGN = DARK GREEN
YEL = YELLOW
PNK = PINK
WHT = WHITE
BRN = BROWN
GRY = GREY

Page 5B - 6671669/6710313 - Printed by Ken Cook Co. - 09/10/2007 10:20:20 - v2.18.1 7/21/2007

753 BOSS - WIRING SCHEMATIC
 WITH HIGH FLOW OPTION
 S/N 512724123-27672
 (PRINTED OCTOBER 2000)
 MC2615

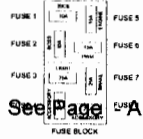
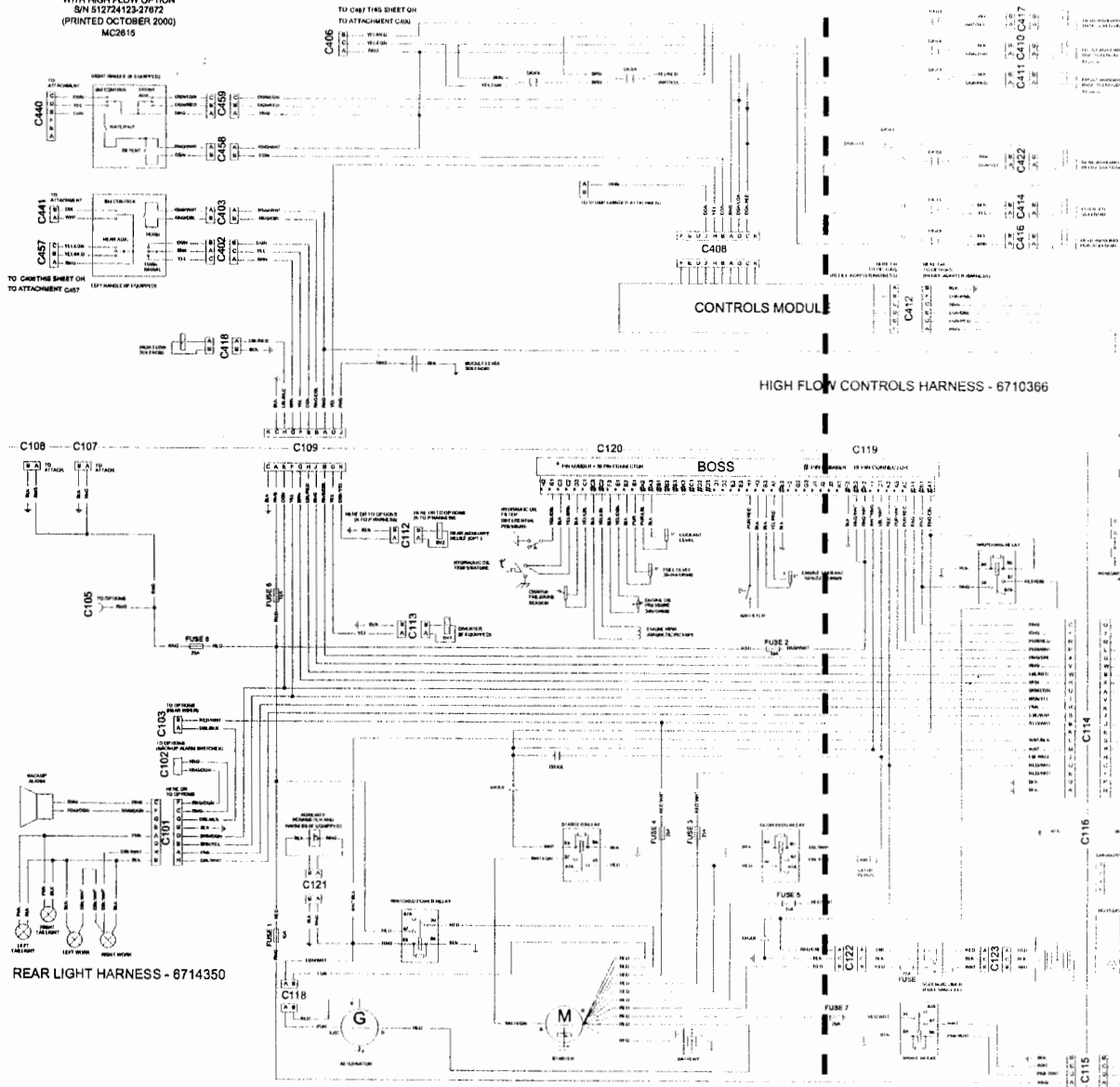

WIRES CONNECT BY LETTER ACROSS CONNECTORS

(A) (B) (C) (D) (E) (F) (G) (H) (I) (J) (K) (L) (M) (N) (O) (P) (Q) (R) (S) (T) (U) (V) (W) (X) (Y) (Z)

SOME CONNECTOR BODIES NOT SHOWN FOR DRAWING CLARITY

RED = RED
 ORG = ORANGE
 BLK = BLACK
 LBL = LIGHT BLUE
 DLU = DARK BLUE
 LGH = LIGHT GREEN
 DGH = DARK GREEN
 WHT = WHITE
 YEL = YELLOW
 PPK = PINK
 BRN = BROWN
 TAN = TAN
 PUR = PURPLE
 GRY = GREY

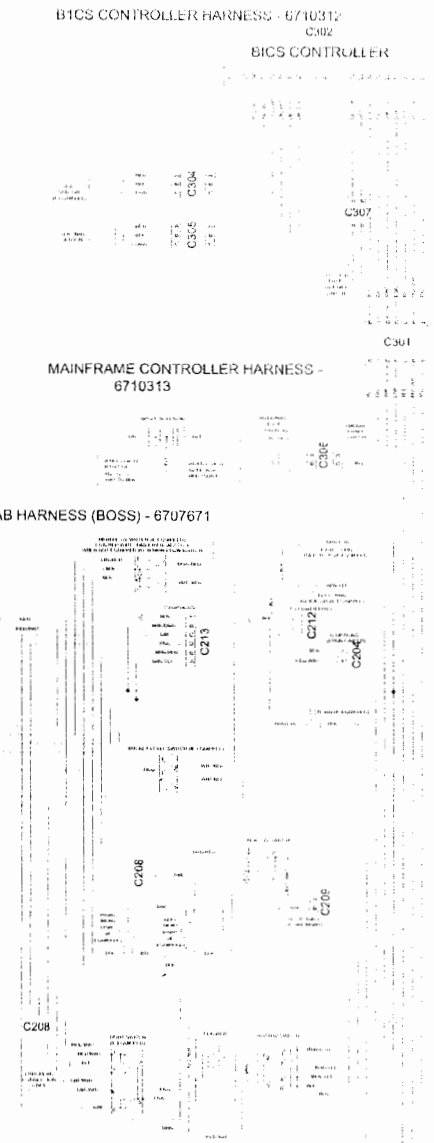

753 BOSS - WIRING SCHEMATIC

WITH HIGH FLOW OPTION

S/N 512724123-27672

(PRINTED OCTOBER 2000)

MC2615

TO OAST THIS SHEET OR
TO ATTACHMENT C439

C106
B - BLK
D - YEL
A - RING



TO C406 THIS SHEET OR
TO ATTACHMENT C457

LEFT HANDLE (IF EQUIPPED)



CONTROLS MODULE

HIGH FLOW CO

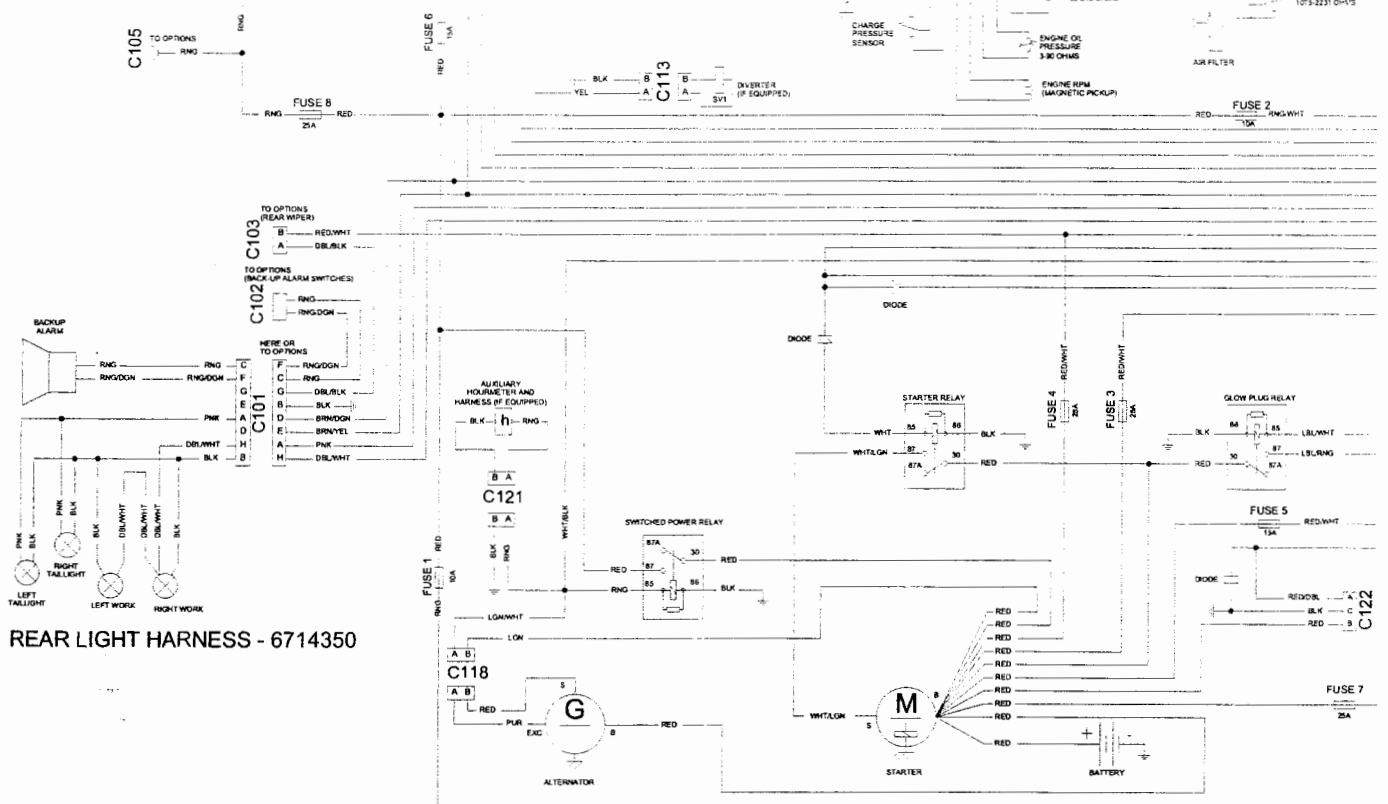
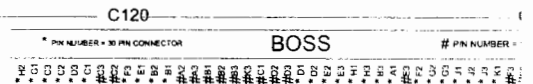
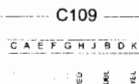
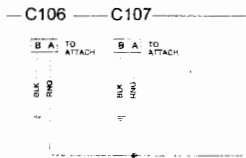

REAR LIGHT HARNESS - 6714350

ENGINE HARNESS (BOSS) - 6709891

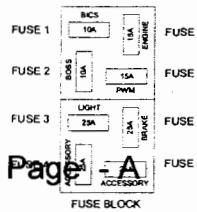

Page J85 - 60580010167B1001 - 09/10/2007 10:20:20 - Printed by Ken Cook Co. - ePrint.exe (v2.18.1 7/21/2007)

C302

BICS CONTROLLER

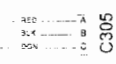
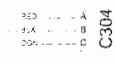

MAINFRAME CONTROLLER HARNESS - 6710313



HIGH FLOW CONTROLS HARNESS - 6710366

C119

BOSS

P/N NUMBER = 16 PIN CONNECTOR

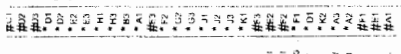

CAB HARNESS (BOSS) - 6707671

C203

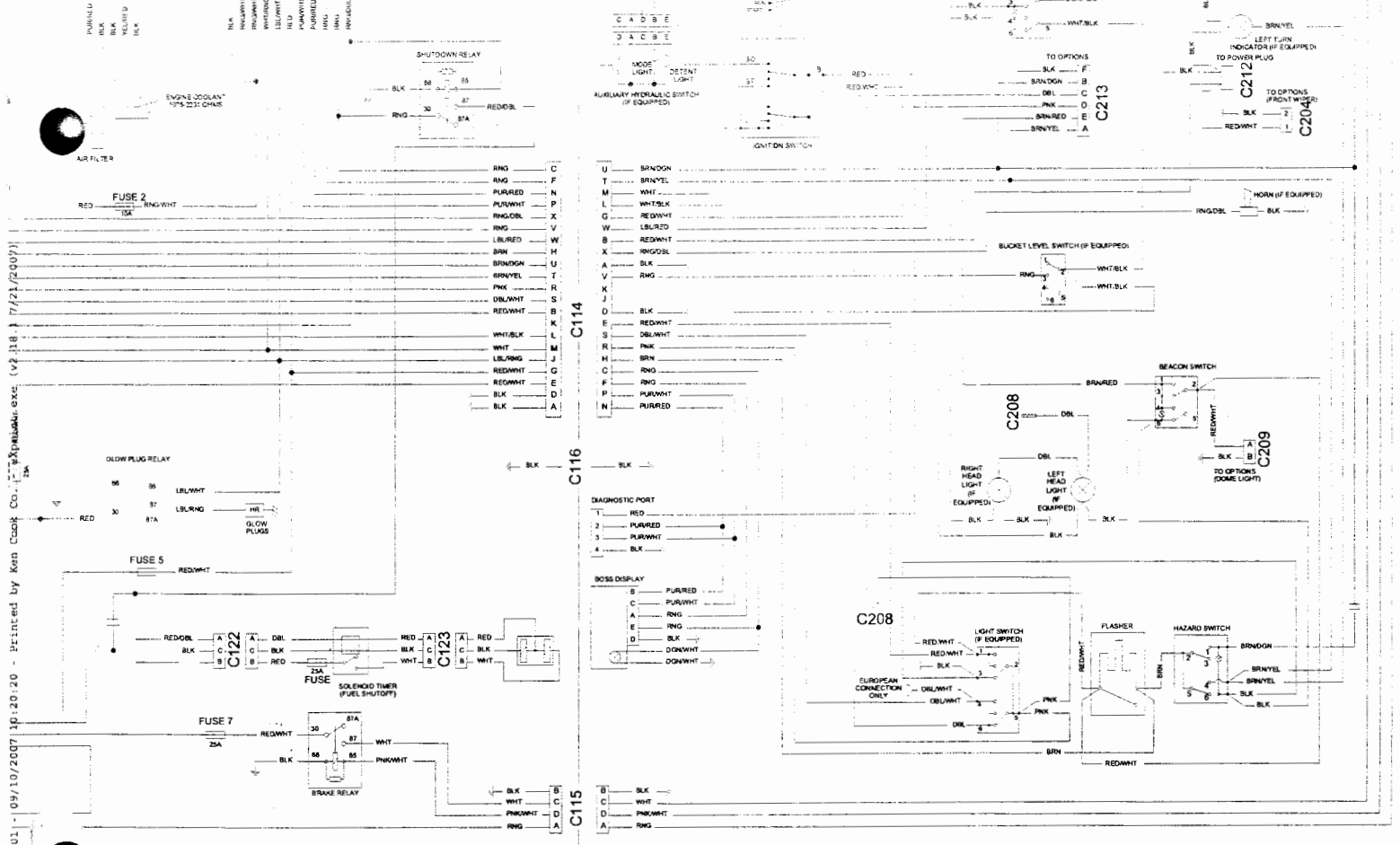
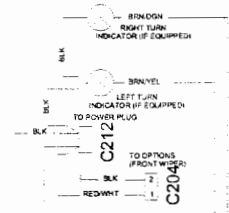
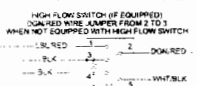

WIRES CONNECT BY LETTER ACROSS CONNECTORS

SOME CONNECTOR BODIES NOT SHOWN FOR DRAWING CLARITY

- RED = RED
RNG = ORANGE
BLK = BLACK
LBL = LIGHT BLUE
DBL = DARK BLUE
LGN = LIGHT GREEN
DGN = DARK GREEN
YEL = YELLOW
PNK = PINK
WHT = WHITE
BRN = BROWN
GRY = GREY

Page 387 - subMU0167B1001 - 09/10/2007 10:20:20 - Printed by Ken Cook Co. - X:\pabak.exe (v2.18.1.7/21/2007)

753 WITHOUT BOSS - WIRING SCHEMATIC
 SN 51227873 AND ABOVE
 SN 515811001-14192
 (PRINTED OCTOBER 2000)
 MC2816

CONTROLS HARNESS - 6712136

IGCS CONTROLLER HARNESS - 6711134
IGCS CONTROLLER

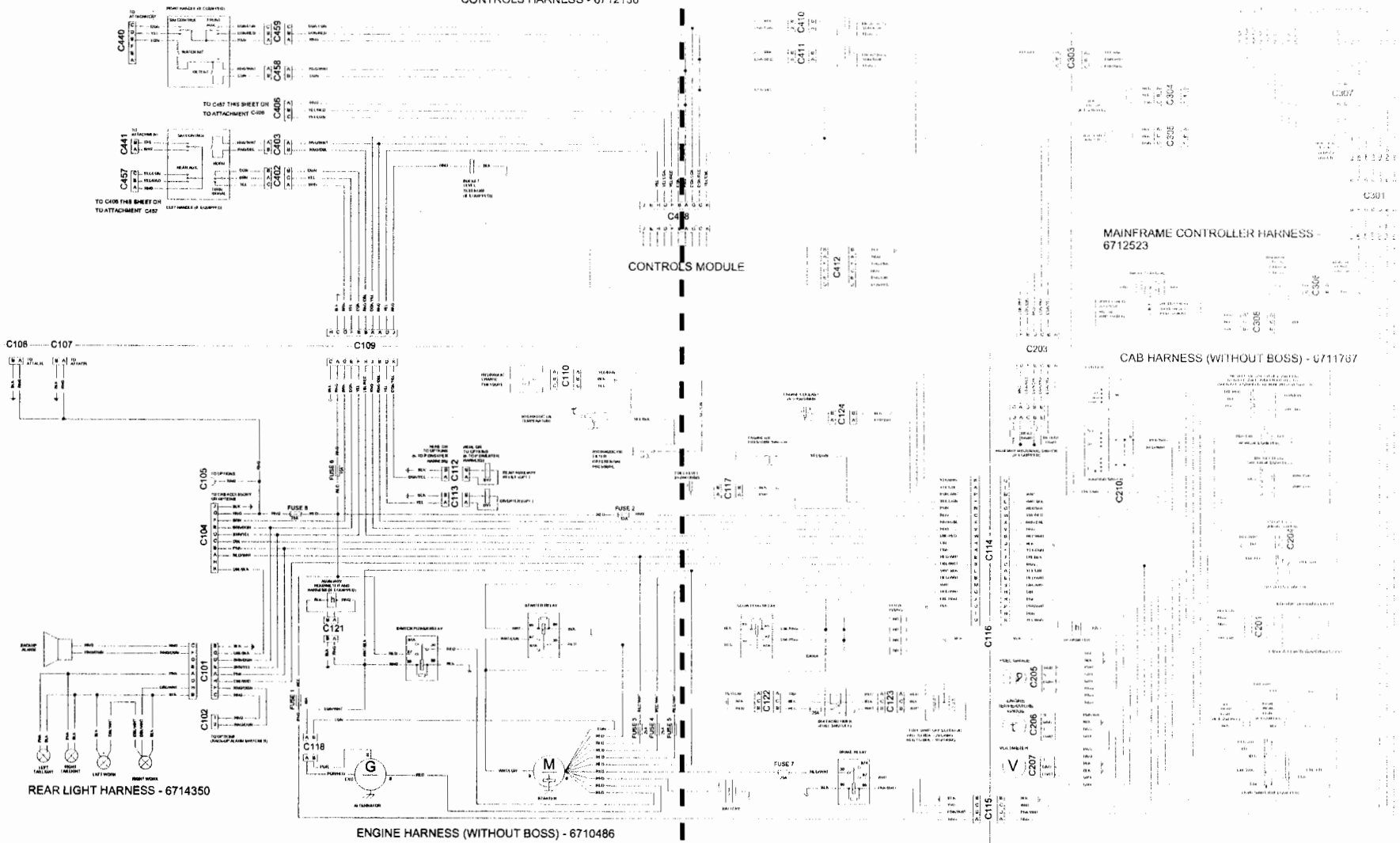

See Page - A

See Page - B

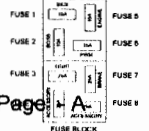

WIRES CONNECT BY LETTER ACROSS CONNECTORS
 A-L
 B-J
 B-A

SOME CONNECTOR BODIES NOT SHOWN FOR DRAWING CLARITY

RED = RED
 ORG = ORANGE
 BLK = BLACK
 LBL = LIGHT BLUE
 DKB = DARK BLUE
 LGN = LIGHT GREEN
 DKG = DARK GREEN
 YEL = YELLOW
 WHI = WHITE
 BRN = BROWN
 TAN = TAN
 PUR = PURPLE
 GRY = GRAY

BICS CONTROLLER

S - 6712136



CONTROLS MODULE



MAINFRAME CONTROLLER HARNESS - 6712523



CAB HARNESS (WITHOUT BOSS) - 6711767

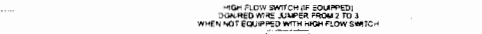

Page 393 - BOBMO10167B1001 - 09/10/2007 10:42:21 - exprint.exe (v2.18.11 7/21/2007) Printed by Ken Cook Co.

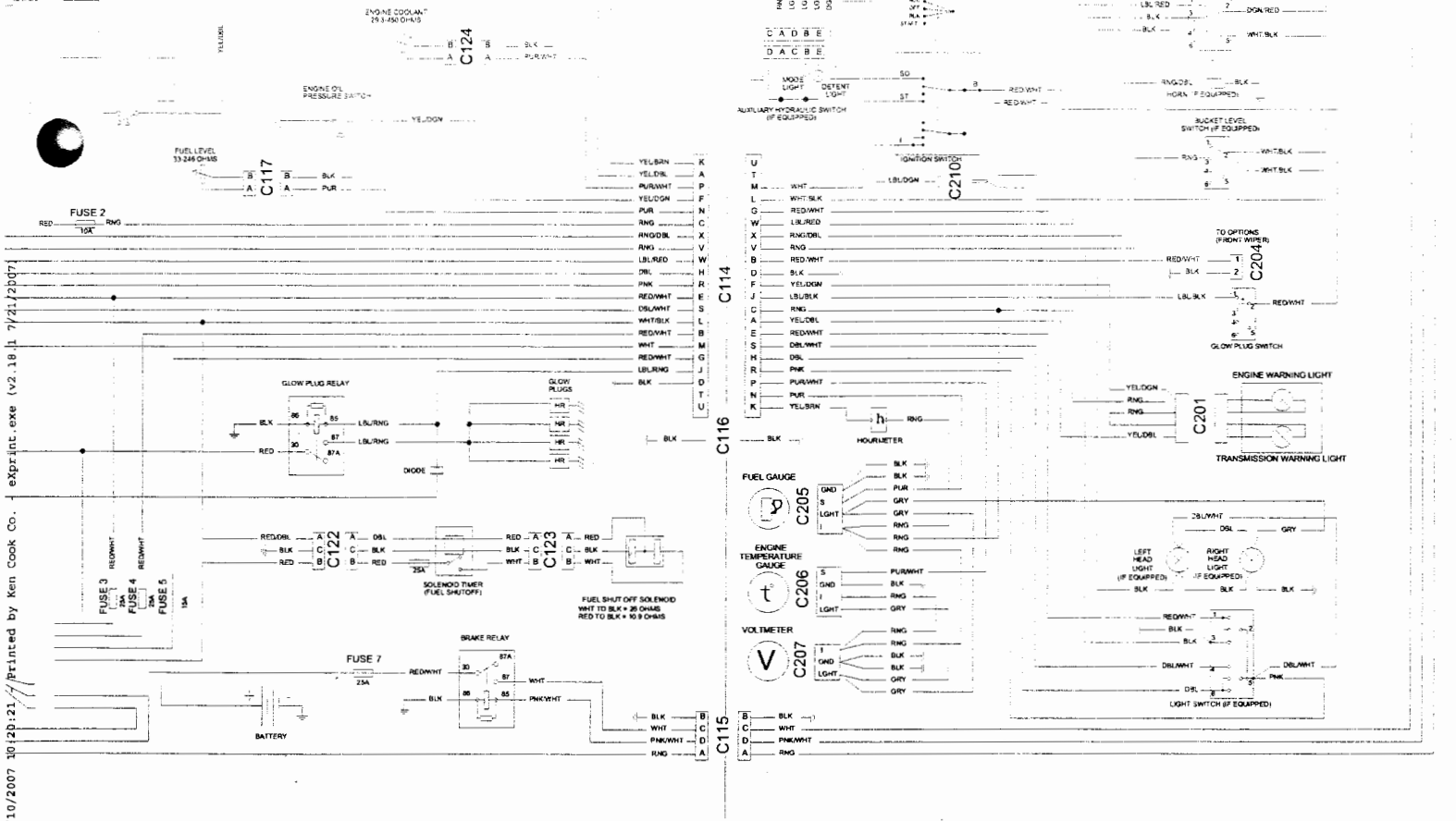

- RED = RED
- RNG = ORANGE
- BLK = BLACK
- LBL = LIGHT BLUE
- DBL = DARK BLUE
- LGN = LIGHT GREEN
- DGN = DARK GREEN
- YEL = YELLOW
- PNK = PINK
- WH = WHITE
- BRN = BROWN
- TAN = TAN
- PUR = PURPLE
- GRY = GREY



SOME CONNECTOR BODIES NOT SHOWN FOR DRAWING CLARITY

753 BOSS - WIRING SCHEMATIC
 SN 512727873 AND ABOVE
 SN 515811001-14183
 (PRINTED OCTOBER 2000)
 MC2018

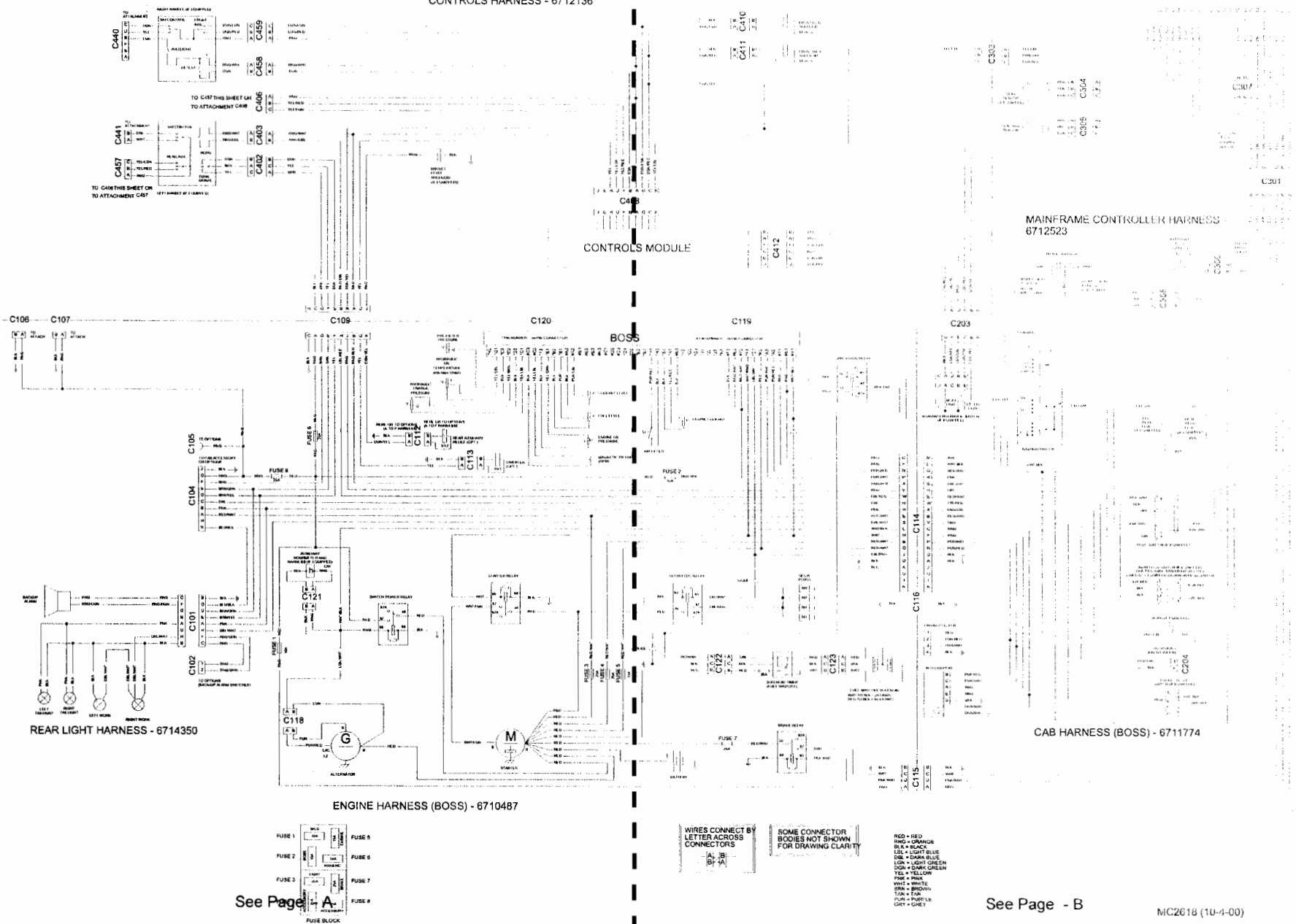

See Page - A

See Page - B

753 BOSS - WIRING SCHEMATIC

S/N 51272673 AND ABOVE
S/N 515811001-14193
(PRINTED OCTOBER 2000)
MC2618

CONTROLS HARNESS - 6712136

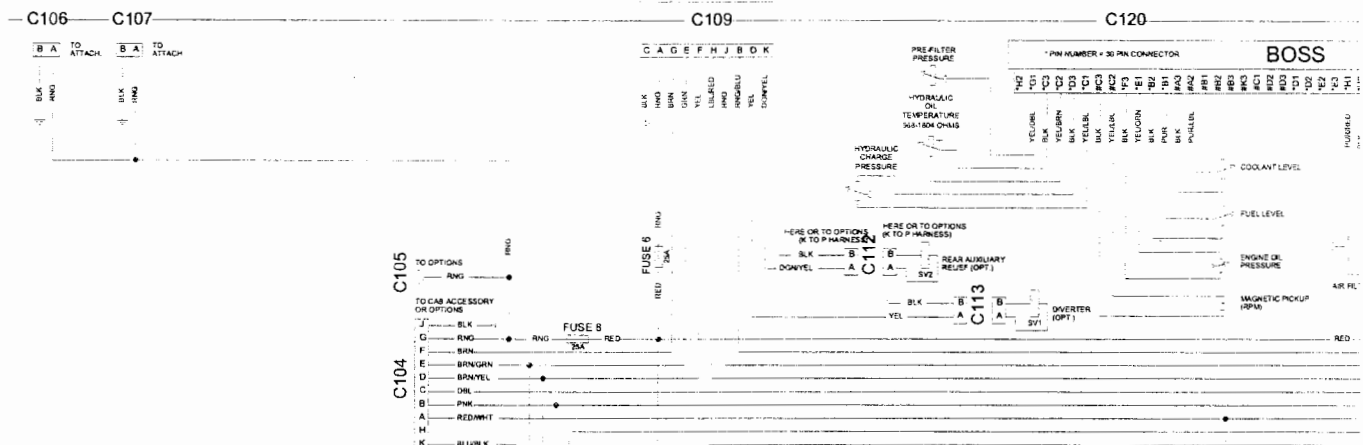
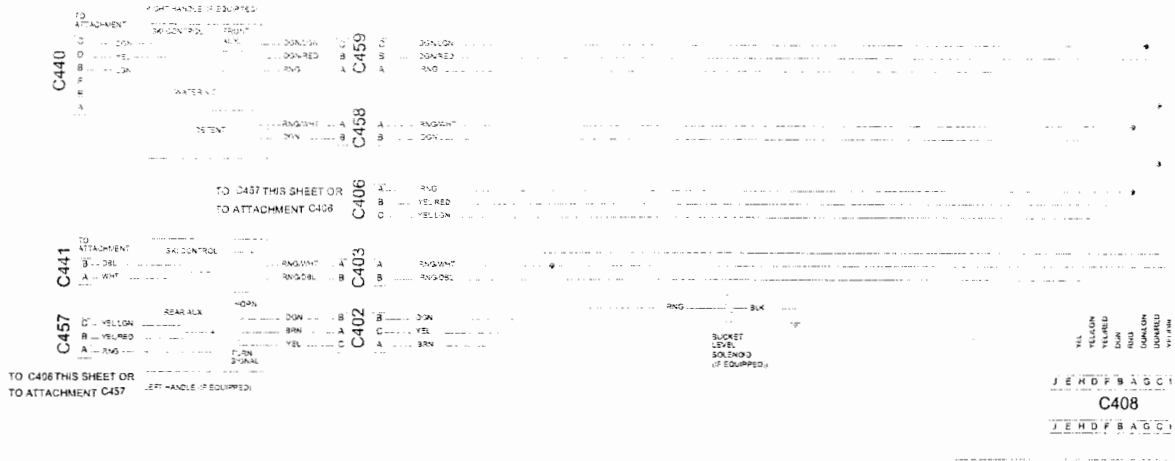

REAR LIGHT HARNESS - 6714350

ENGINE HARNESS (BOSS) - 6710487

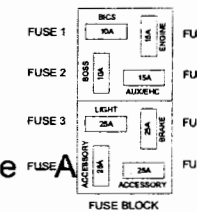
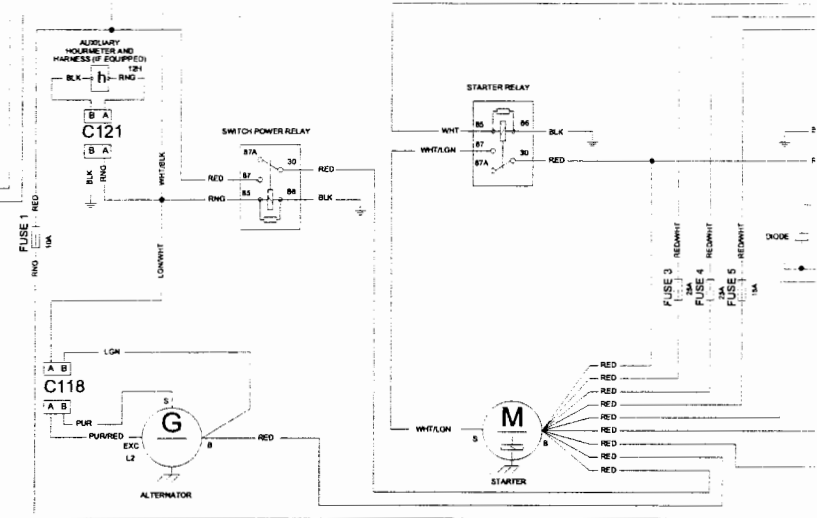

Page 597 - 804R01016/H1001 - 09/10/2007 10:20:21 - Printed by Ken Cook Co. - ePrint.exe (v2.18.1 7/21/2007)

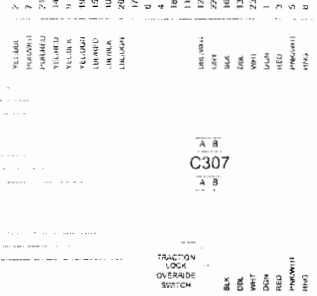

CONTROLS MODULE

MAINFRAME CONTROLLER HARNESS - 6712523

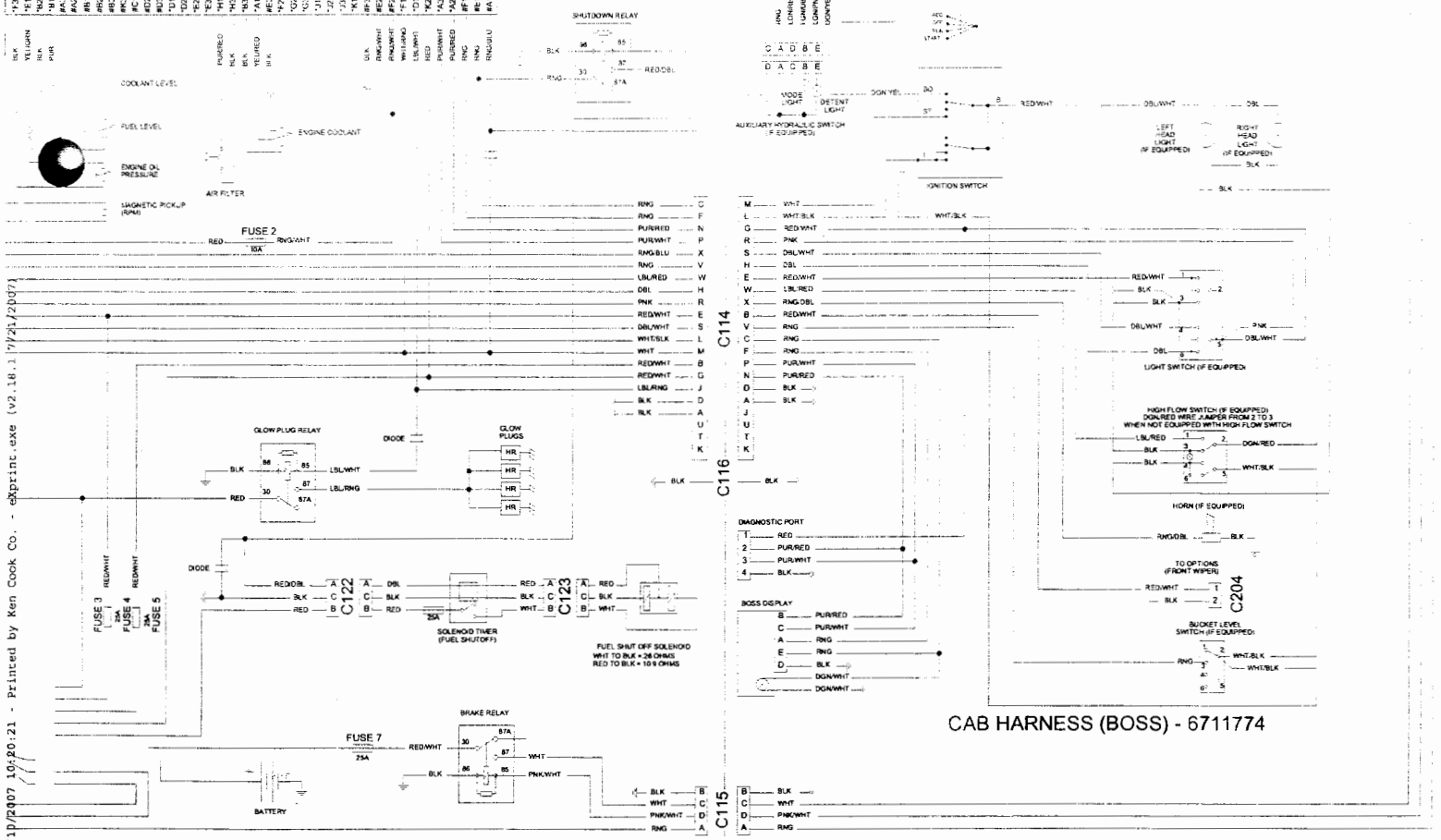
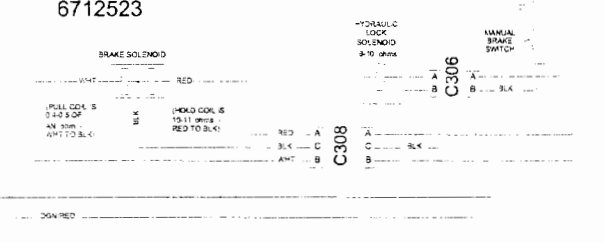
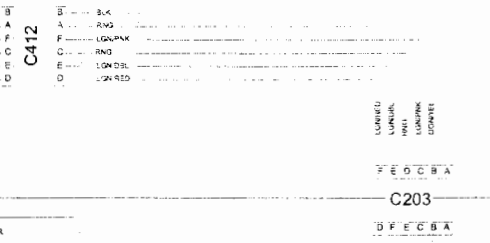
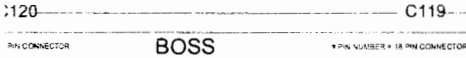

WIRES CONNECT BY LETTER ACROSS CONNECTORS

A	B
B	A

SOME CONNECTOR BODIES NOT SHOWN FOR DRAWING CLARITY

RED = RED
 RING = ORANGE
 BLK = BLACK
 LBL = LIGHT BLUE
 DBL = DARK BLUE
 LGN = LIGHT GREEN
 DGM = DARK GREEN
 YEL = YELLOW
 PNK = PINK
 WHT = WHITE
 BRN = BROWN
 TAN = TAN
 PUR = PURPLE
 GRE = GREY

Page 399 - BOBM010167B1001 - 09/13/2007 10:20:21 - Printed by Ken Cook Co. - ePrint.exe (v2.18.1) 7/21/2007

753 WITHOUT BOSS - WIRING SCHEMATIC
 SN 515614104-19114
 (PRINTED OCTOBER 2000)
 MC2619

BICS CONTROLLER HARNESS - 6712134
 BICS CONTROLLER

CONTROLS HARNESS - 6712136

MAINFRAME CONTROLLER HARNESS - 6712523

CAB HARNESS (WITHOUT BOSS) - 6711767

FILTER HARNESS (WITHOUT BOSS) - 6715880

ENGINE HARNESS (WITHOUT BOSS) - 6715892

REAR LIGHT HARNESS - 6714350

CONTROLS MODULE

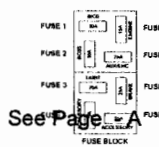
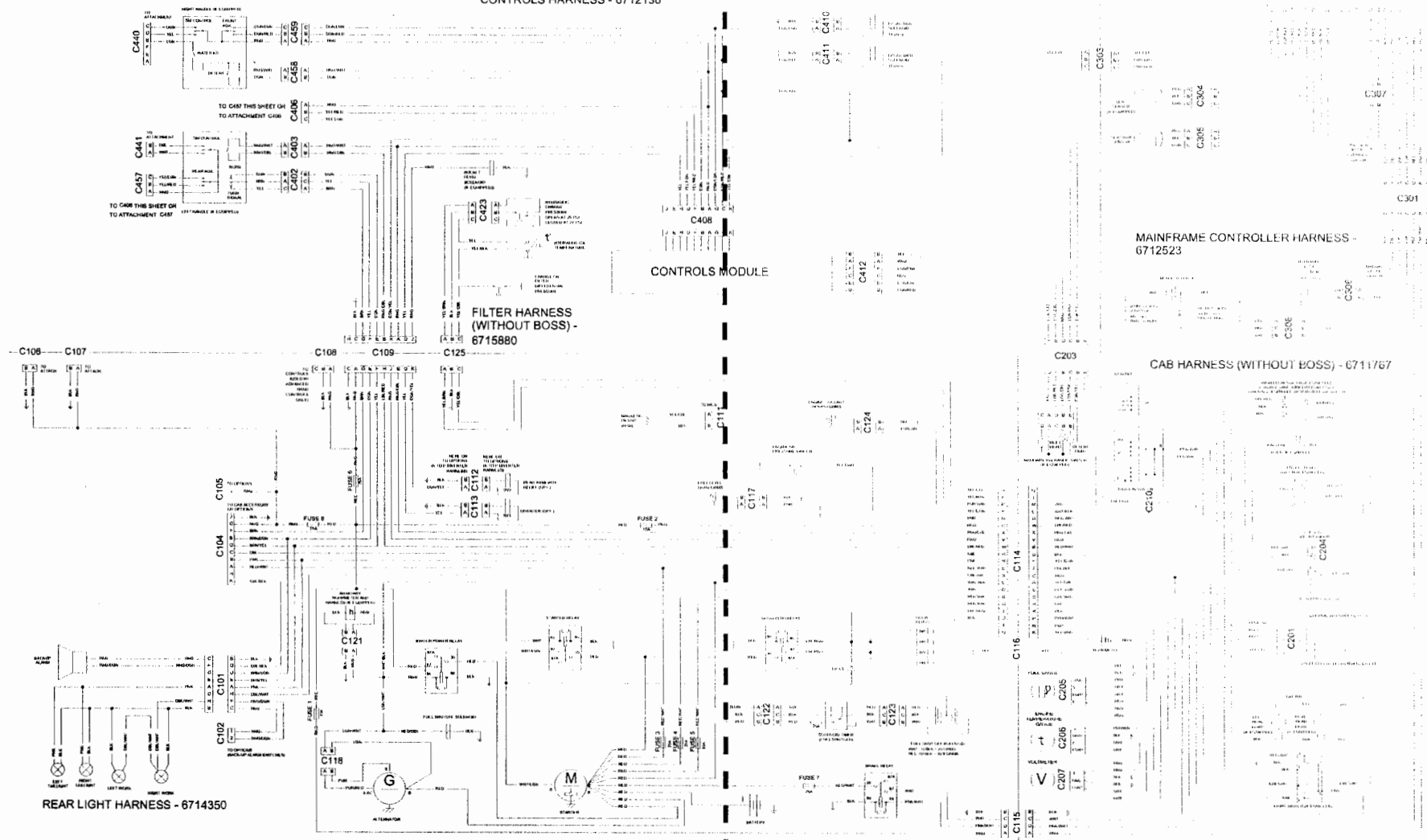

WIRES CONNECT BY LETTER ACROSS CONNECTORS
 SOME CONNECTOR BODIES NOT SHOWN FOR DRAWING CLARITY

RED = RED
 ORNG = ORANGE
 BLK = BLACK
 WHT = WHITE
 GRN = GREEN
 YEL = YELLOW
 DKN = DARK GREEN
 LGRN = LIGHT GREEN
 DGN = DARK GREEN
 PPK = PINK
 BRN = BROWN
 TAN = TAN
 PUR = PURPLE
 GRY = GREY

See Page - A

See Page - B

BICS CONTROLLER

S - 6712136

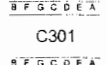
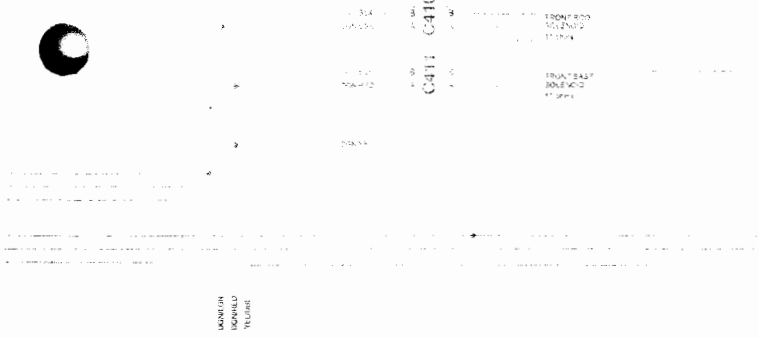
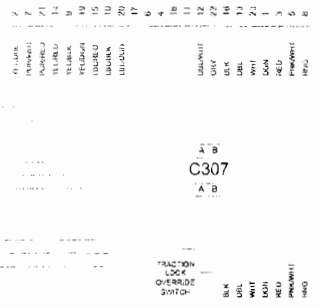

MAINFRAME CONTROLLER HARNESS - 6712523

CONTROLS MODULE

C408

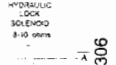
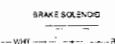

CAB HARNESS (WITHOUT BOSS) - 6711767

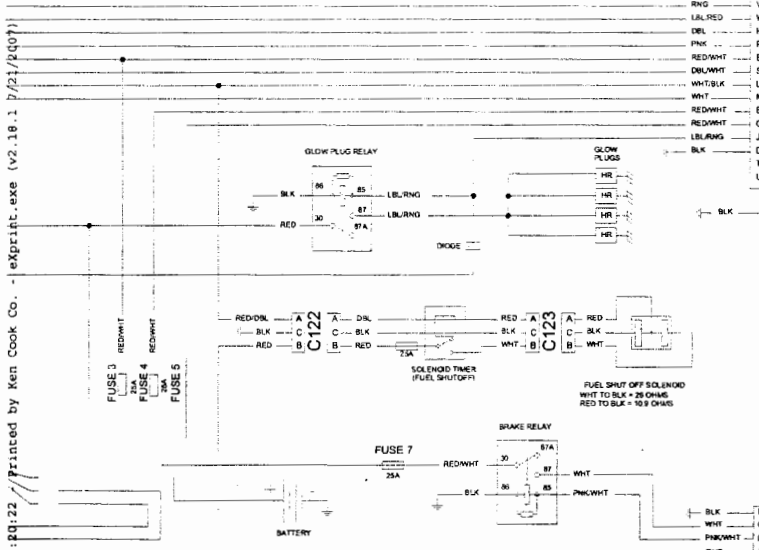
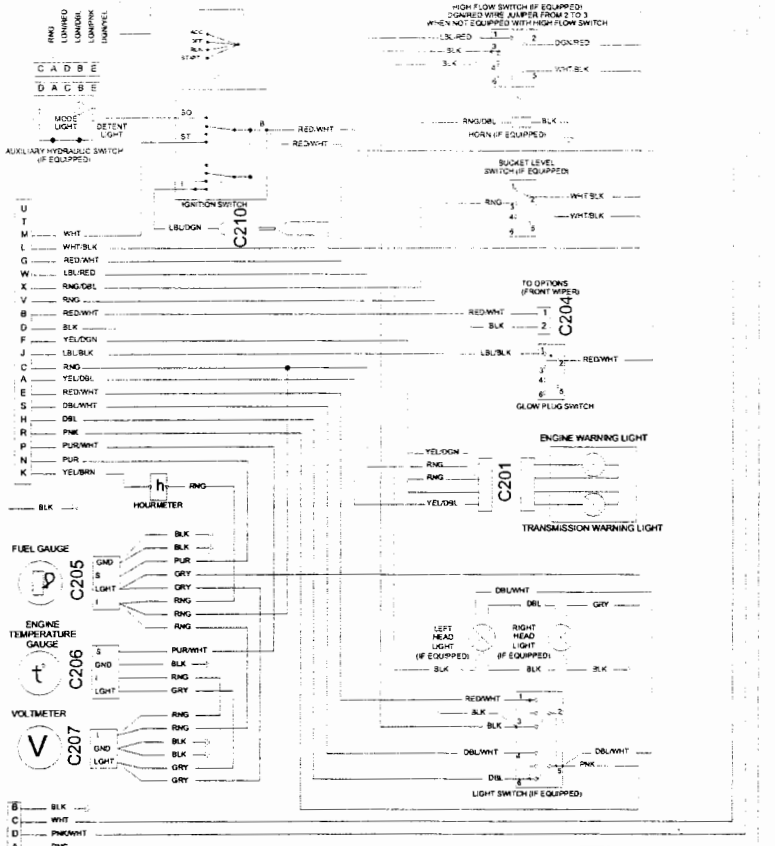
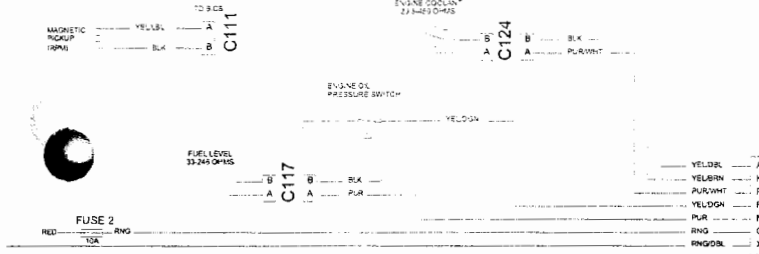

15892

WIRES CONNECT BY LETTER ACROSS CONNECTORS

A	B
B	A

SOME CONNECTOR BODIES NOT SHOWN FOR DRAWING CLARITY

RED = RED
 RNG = ORANGE
 BLK = BLACK
 LBL = LIGHT BLUE
 DBL = DARK BLUE
 LGN = LIGHT GREEN
 DGN = DARK GREEN
 YEL = YELLOW
 PNK = PINK
 WHT = WHITE
 BRN = BROWN
 TAN = TAN
 PUR = PURPLE
 GRY = GREY

753 BOSS - WIRING SCHEMATIC
 SN 515814104-19114
 (PRINTED OCTOBER 2000)
 MC2620

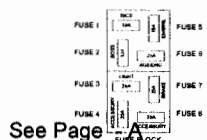
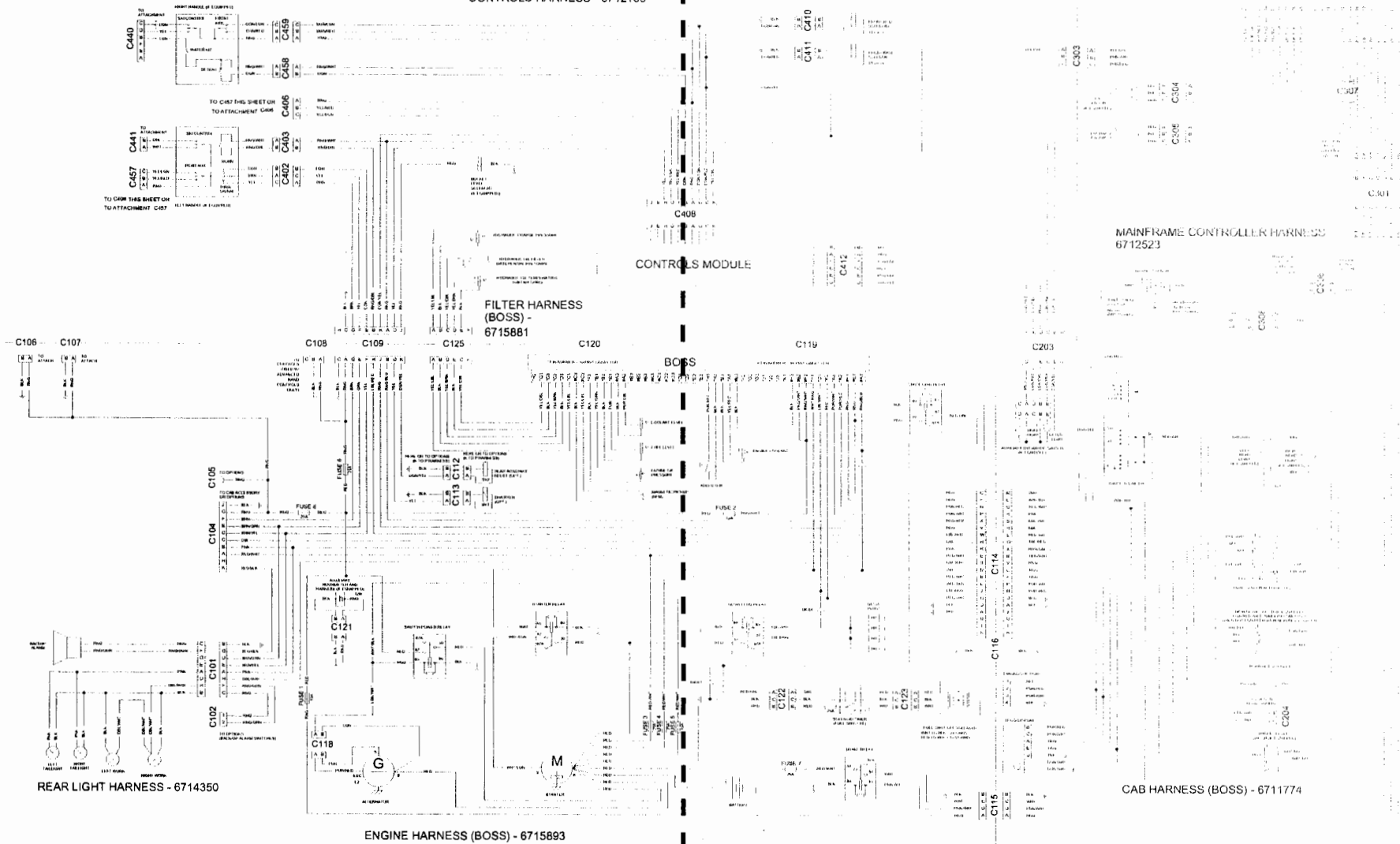

See Page A

WIRES CONNECT BY LETTER ACROSS CONNECTORS
 A1 B1
 B1 A1

SOME CONNECTOR BODIES NOT SHOWN FOR DRAWING CLARITY

RED = RED
 ORN = ORANGE
 BLK = BLACK
 LBL = LIGHT BLUE
 DBL = DARK BLUE
 LGN = LIGHT GREEN
 DGN = DARK GREEN
 YEL = YELLOW
 PUR = PURPLE
 WHI = WHITE
 BRN = BROWN
 TAN = TAN
 GRN = GREEN
 GRY = GRAY

See Page - B

MC2620 (10-4-00)

753 BOSS - WIRING SCHEMATIC

S/N 515814194-19114
 (PRINTED OCTOBER 2000)
 MC2820

CONTROLS HARNESS - 6712136

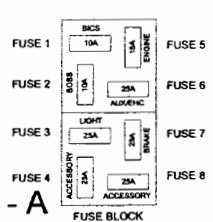
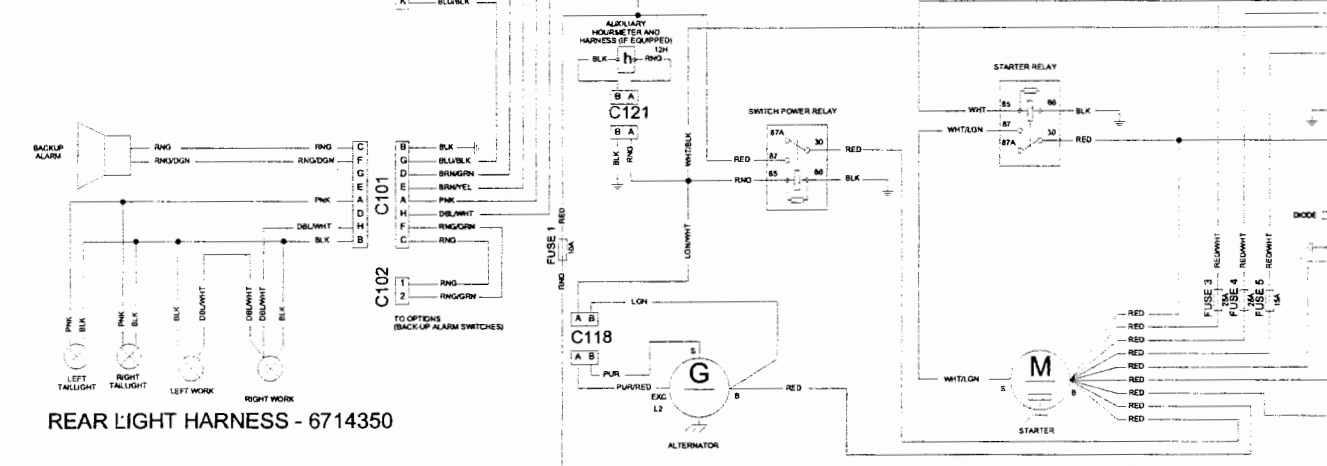
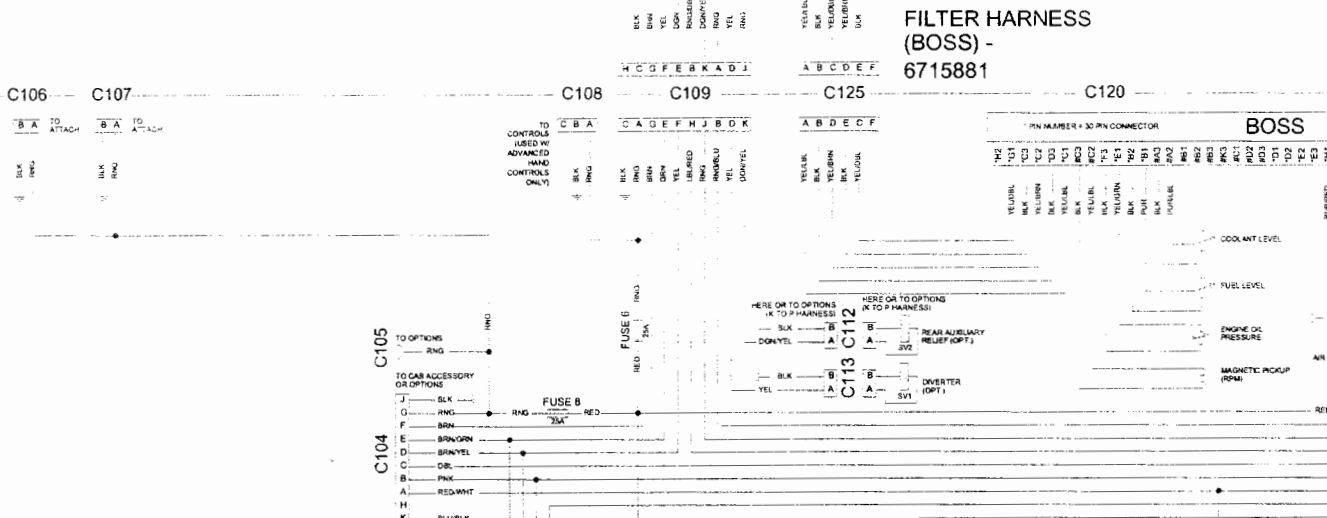
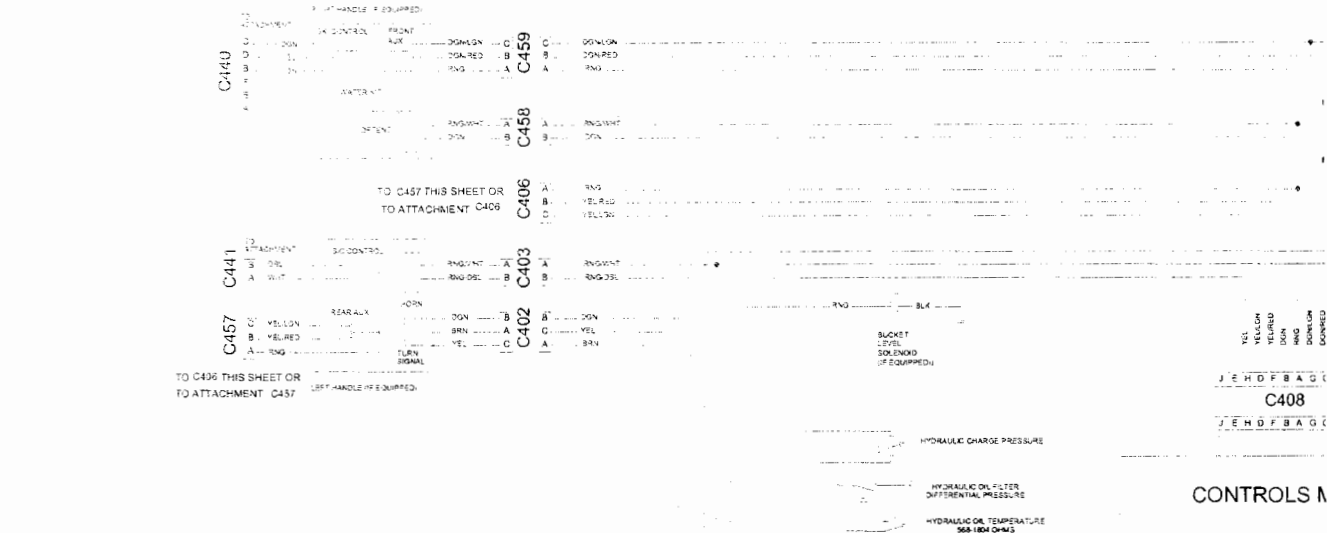

Page 409 - BUJMKJ016/BJ001 - 09/10/2007 10:20:22 - Printed by Ken Cook Co. - exprint.exe (v2.18.1 7/21/2007)

BICS CONTROLLER

6712136

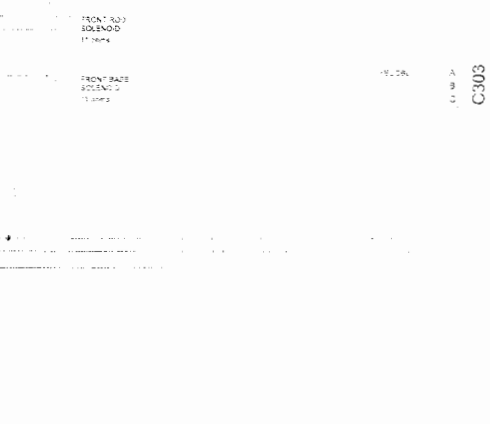

CONTROLS MODULE

MAINFRAME CONTROLLER HARNESS - 6712523

BOSS

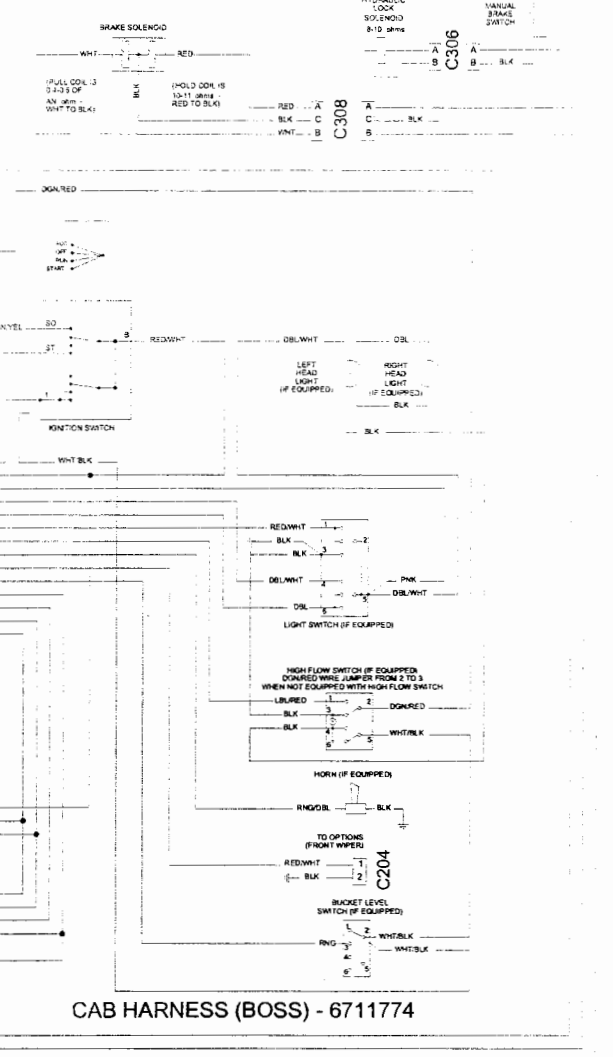
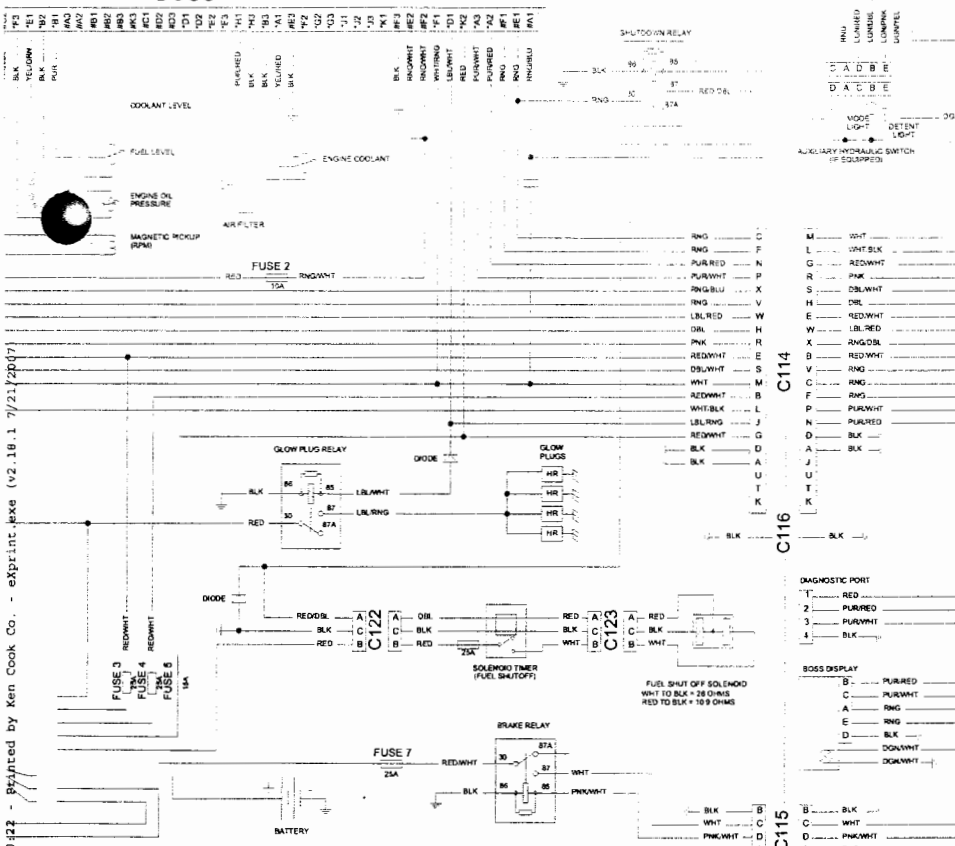

CAB HARNESS (BOSS) - 6711774

Wires connect by letter across connectors

SOME CONNECTOR BODIES NOT SHOWN FOR DRAWING CLARITY

RED = RED
 RNG = ORANGE
 BLK = BLACK
 LBL = LIGHT BLUE
 DBL = DARK BLUE
 LGN = LIGHT GREEN
 DGN = DARK GREEN
 YEL = YELLOW
 PNK = PINK
 WHI = WHITE
 BRN = BROWN
 TAN = TAN
 PUR = PURPLE
 GRY = GREY

Printed by Ken Cook Co. - exprint.exe (v2.18.1 7/21/2007) - 09/10/2007 10:20:22 - edge 411 - BOSKULIB/BL001

753 WITHOUT BOSS - WIRING SCHEMATIC
 SN 616810115-18274
 (PRINTED OCTOBER 2000)
 MC2621

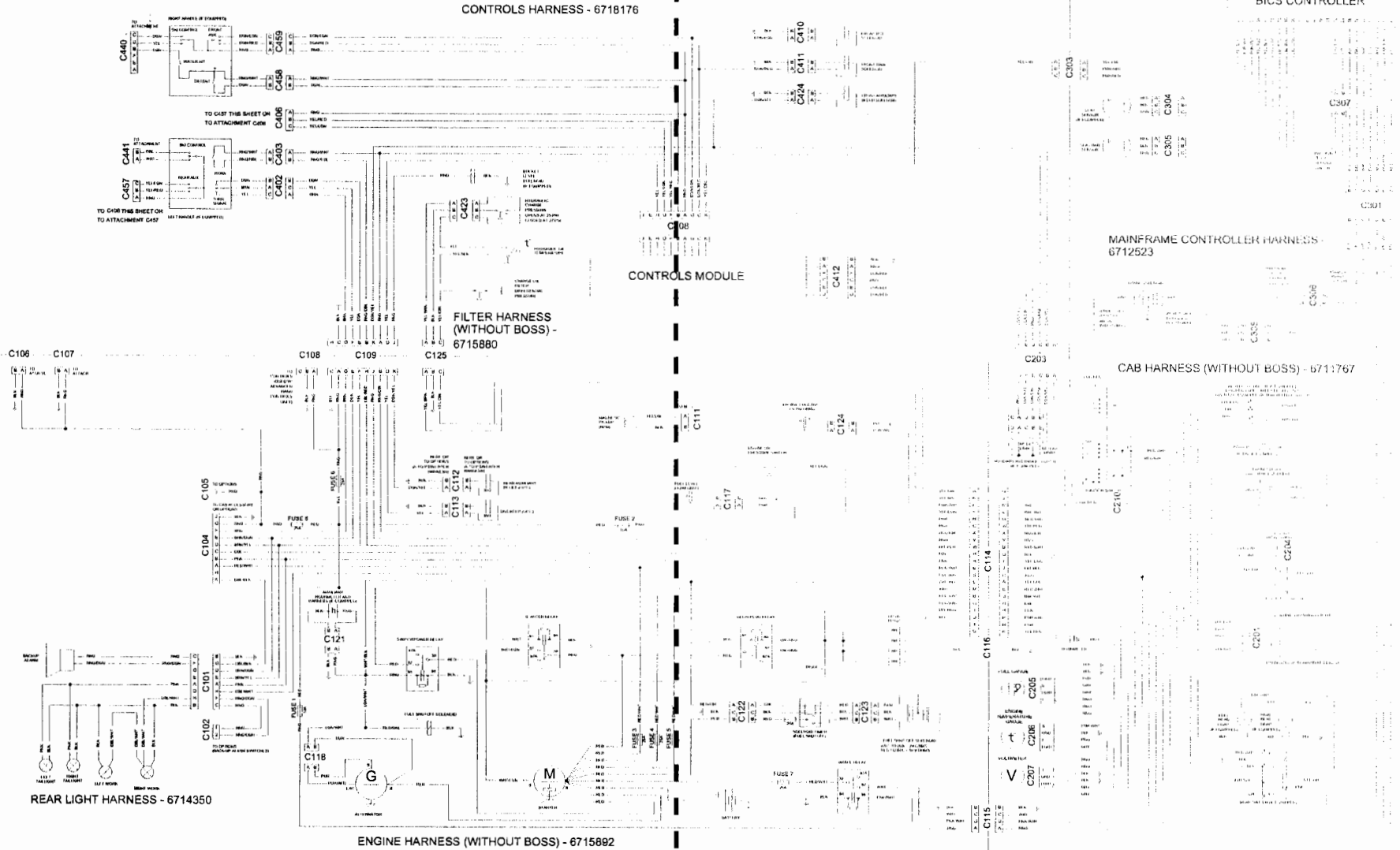

See Page **A**

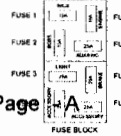

WIRES CONNECT BY LETTER ACROSS CONNECTORS
 (A) (B)
 (1) (2)

SOME CONNECTOR BODIES NOT SHOWN FOR DRAWING CLARITY

RED = RED
 BRN = BROWN
 BLK = BLACK
 LBN = LIGHT BLUE
 LGN = LIGHT GREEN
 YEL = YELLOW
 WHI = WHITE
 GRN = GREEN
 PUR = PURPLE
 GRY = GRAY

See Page - B

753 WITHOUT BOSS - WIRING SCHEMATIC

S/N 315813115-13274
 PRINTED OCTOBER 2000
 MC2921

CONTROLS HARNESS - 6718176

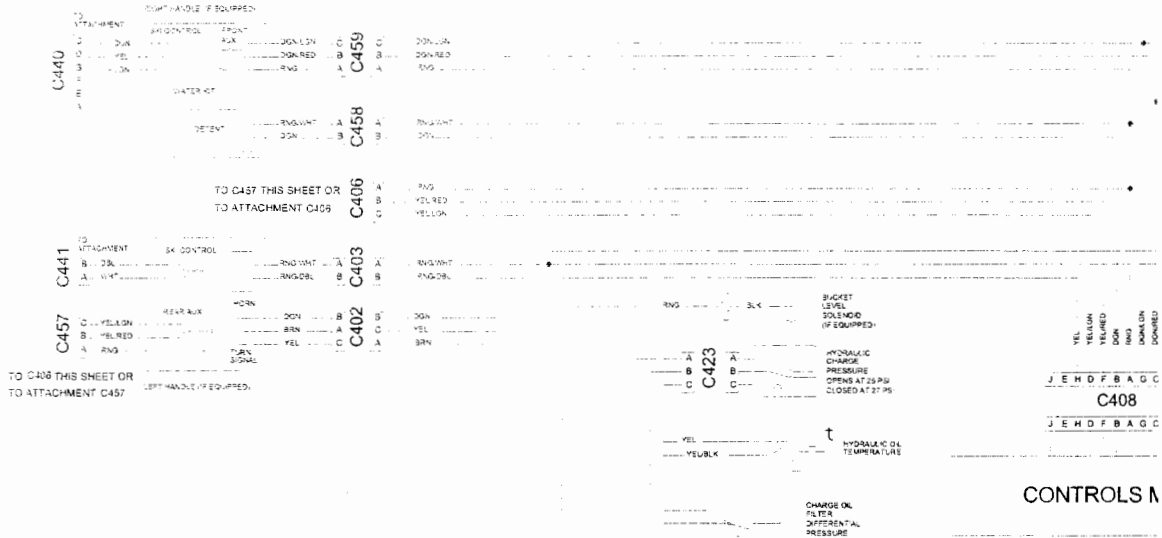

CONTROL HARNESS
 (WITHOUT BOSS) -
 6715880

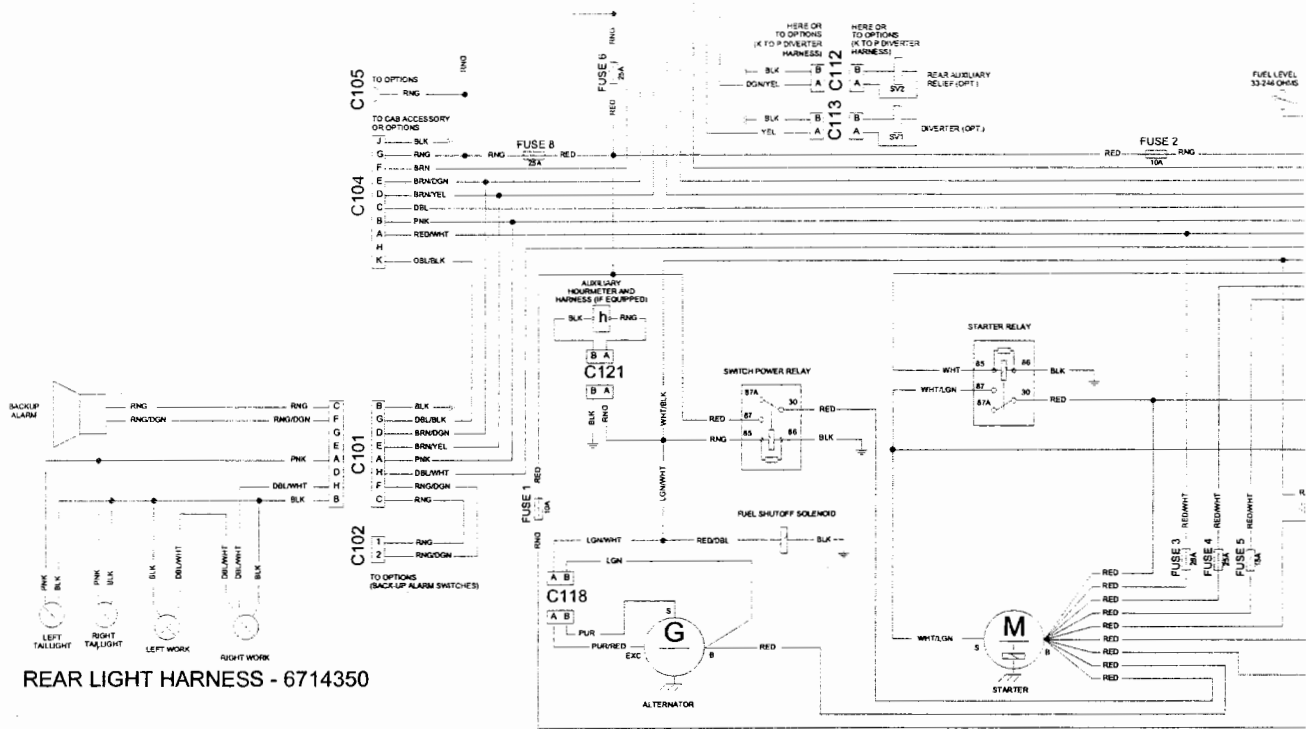
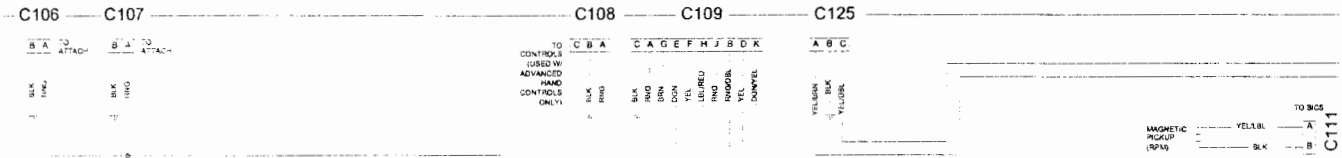

REAR LIGHT HARNESS - 6714350

ENGINE HARNESS (WITHOUT BOSS) - 6715892

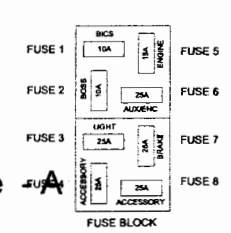

Page 415 - BOSH01016781001 - 09/10/2007 10:20:23 - Printed by Ken Cook Co. - exprtinc.exe (vz.18.1 7/21/2007)

BICS CONTROLLER

S - 6718176

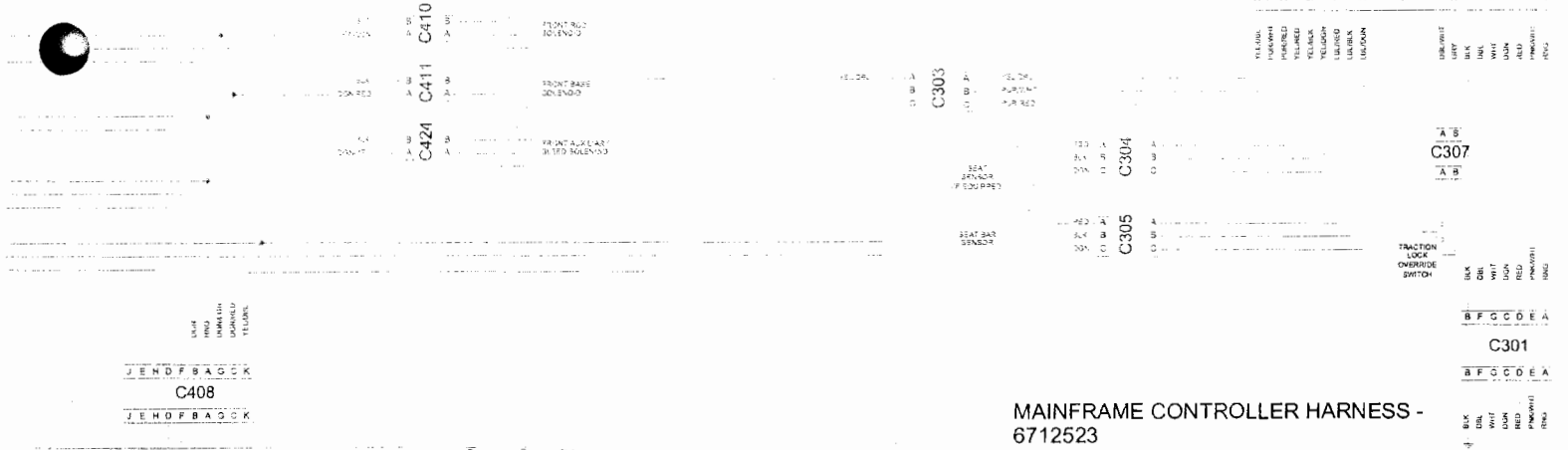

CONTROLS MODULE

MAINFRAME CONTROLLER HARNESS - 6712523

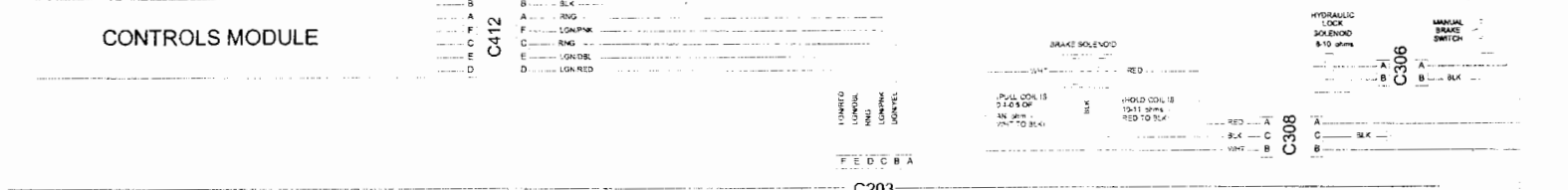

CAB HARNESS (WITHOUT BOSS) - 6711767

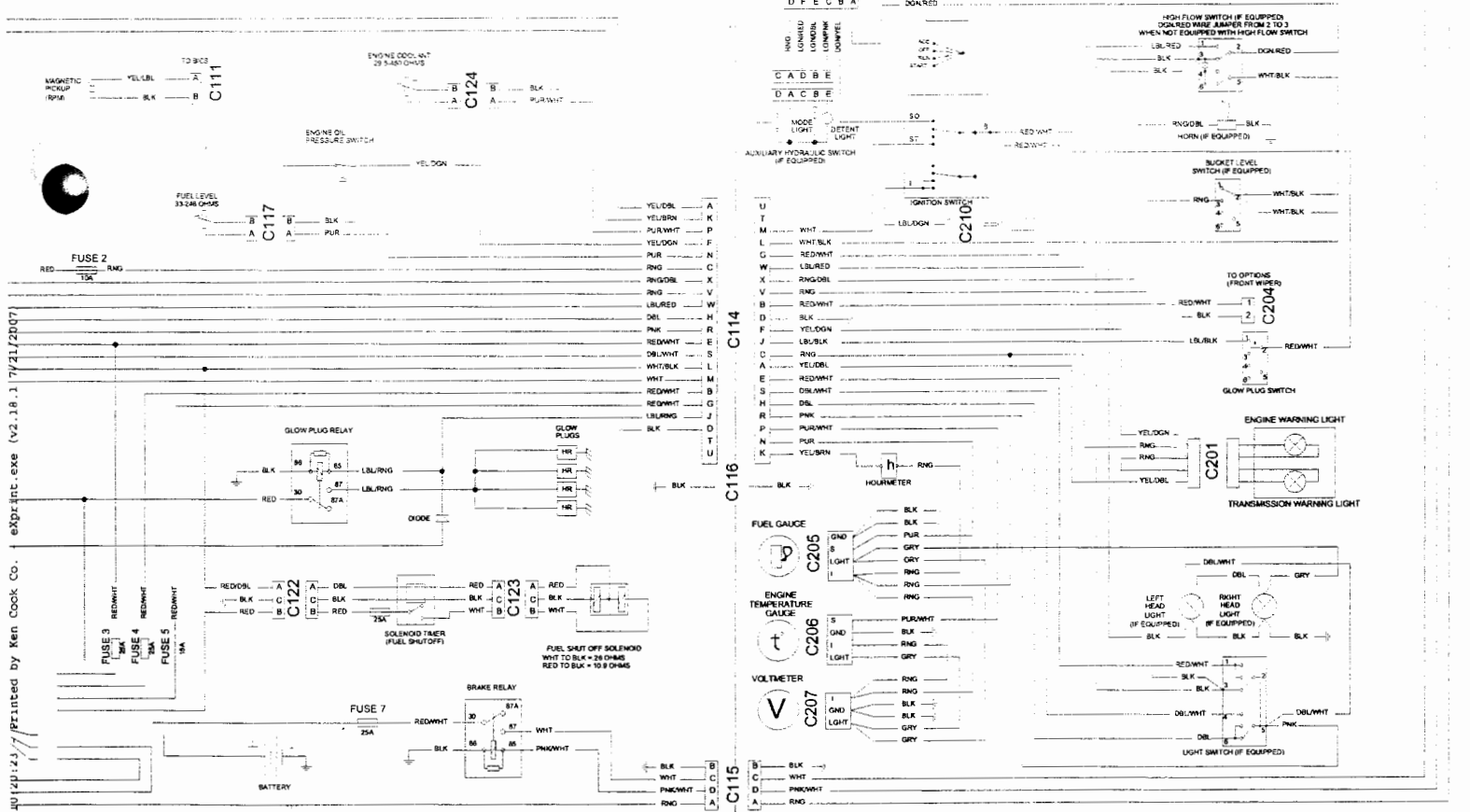

10/24/2007 10:42:43 AM / printed by Ken Cook Co. / S:\PRINT\10712134\10712134.DWG

15892

WIRES CONNECT BY LETTER ACROSS CONNECTORS
A-B
B-A

SOME CONNECTOR BODIES NOT SHOWN FOR DRAWING CLARITY

RED = RED
RNG = ORANGE
BLK = BLACK
LBL = LIGHT BLUE
DBL = DARK BLUE
LGN = LIGHT GREEN
DGN = DARK GREEN
YEL = YELLOW
PNK = PINK
WHT = WHITE
BRN = BROWN
TAN = TAN
PUR = PURPLE
GRY = GREY

753 BOSS - WIRING SCHEMATIC
 SN 515819118-10274
 (PRINTED OCTOBER 2000)
 MC2622

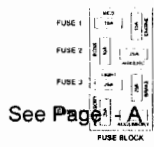
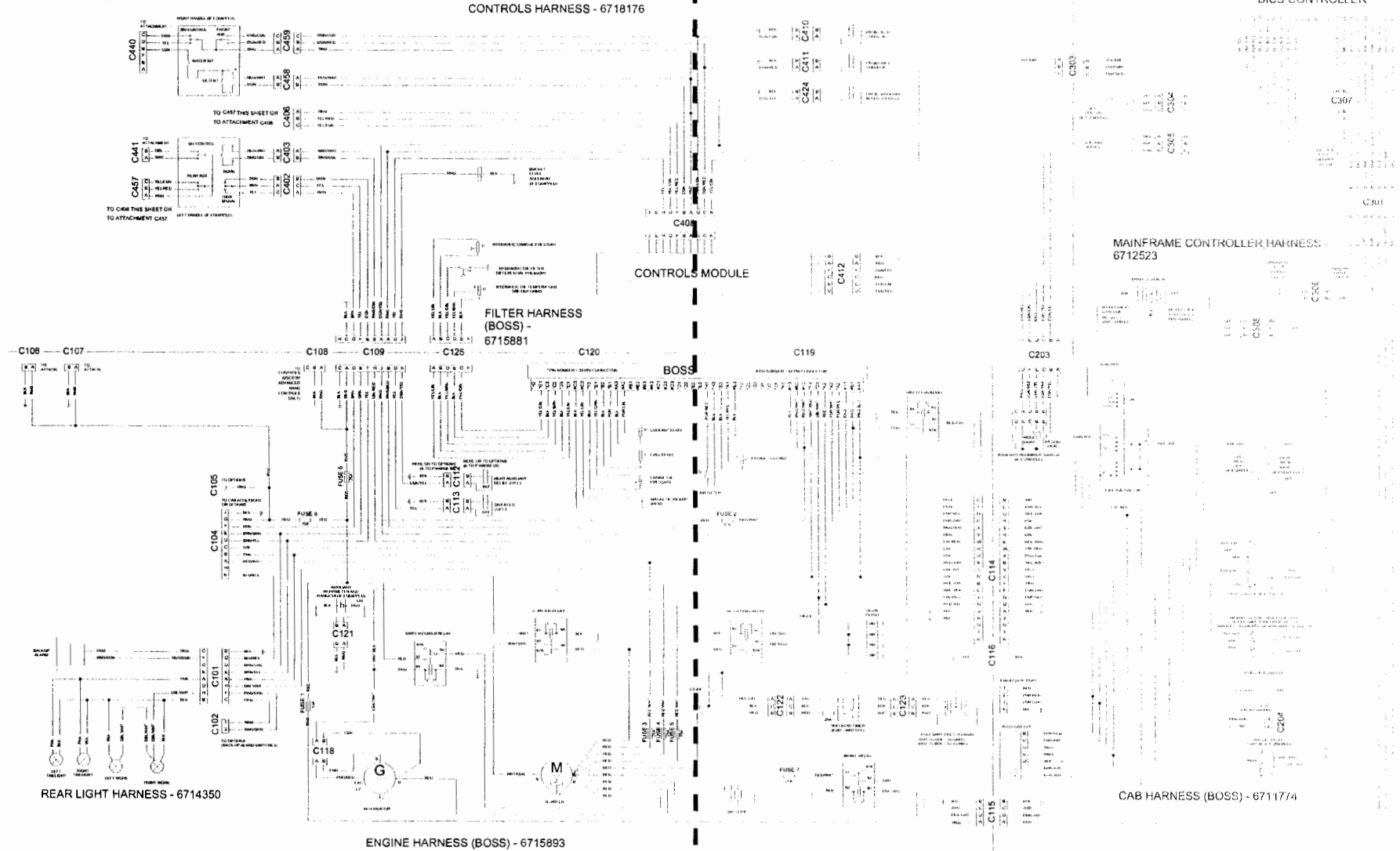

WIRES CONNECT BY LETTER ACROSS CONNECTORS

SOME CONNECTOR BODIES NOT SHOWN FOR DRAWING CLARITY

RED = RED
 BLD = BROWN
 BLK = BLACK
 LBL = LIGHT BLUE
 DBL = DARK BLUE
 LGN = LIGHT GREEN
 GRN = GREEN
 YEL = YELLOW
 WHT = WHITE
 BRN = BROWN
 TAN = TAN
 PUR = PURPLE
 GRN = GREEN

753 BOSS - WIRING SCHEMATIC

S/N 515819115-13274
 (PRINTED OCTOBER 2000)
 MC2622

CONTROLS HARNESS - 6718176

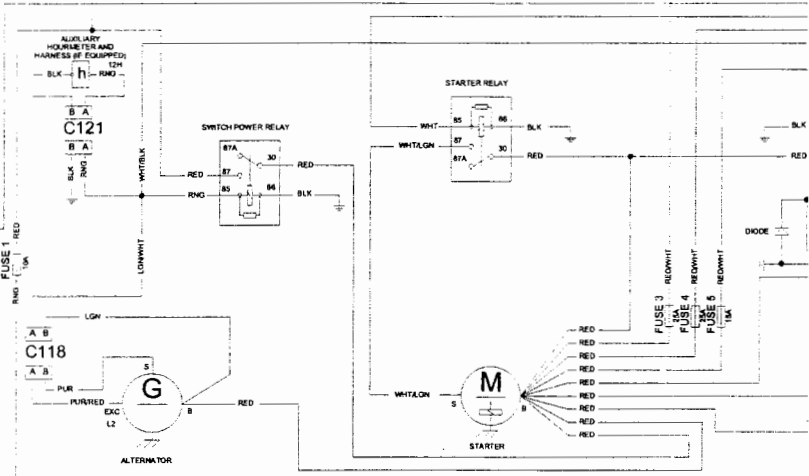
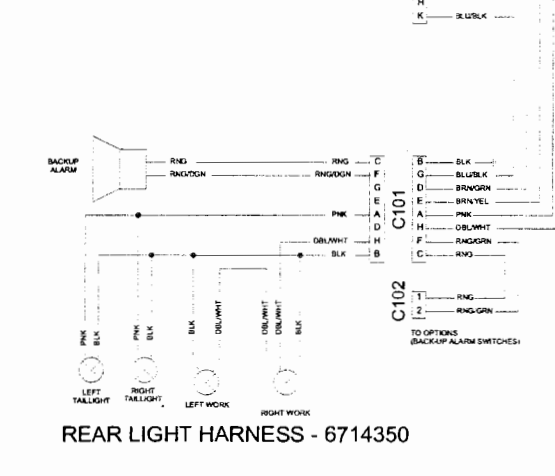
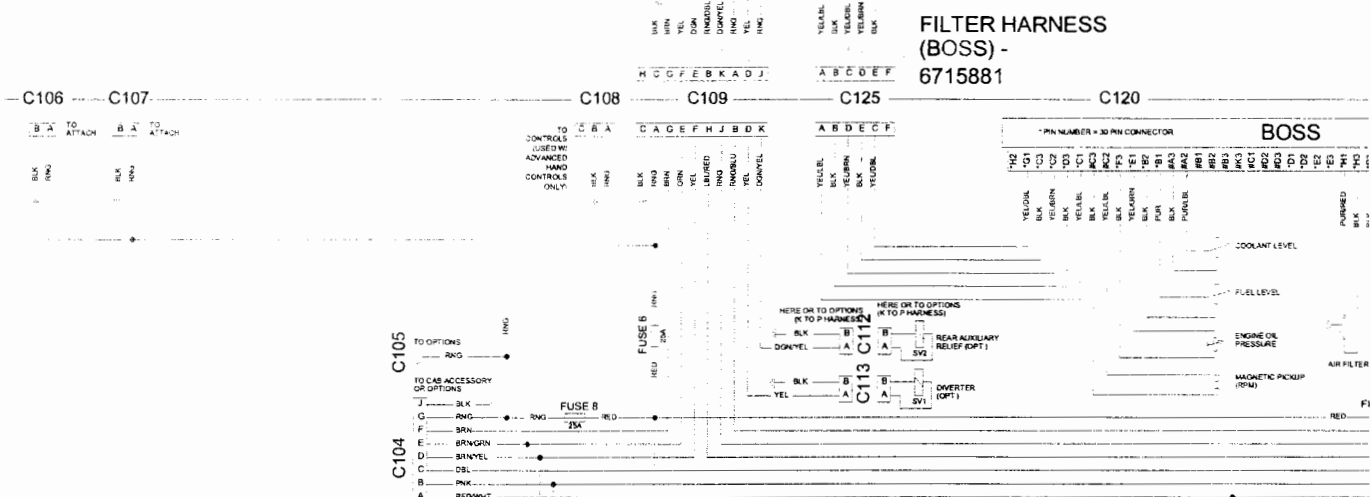
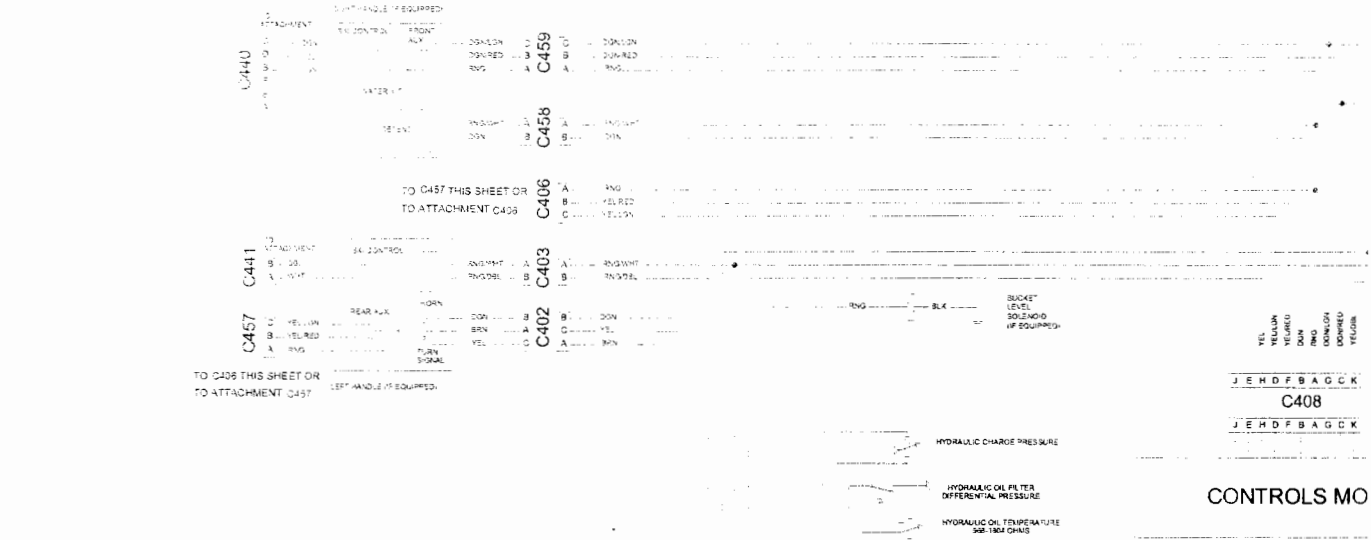

REAR LIGHT HARNESS - 6714350

ENGINE HARNESS (BOSS) - 6715893

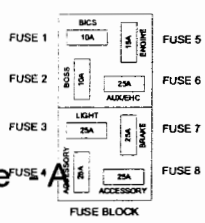

Page 4.21 - subp.u01b/r1001 - 09/10/2007 10:20:23 - Printed by Ken Cook Co. - ePrint.exe (v2.18.1 7/21/2007)

BICS CONTROLLER

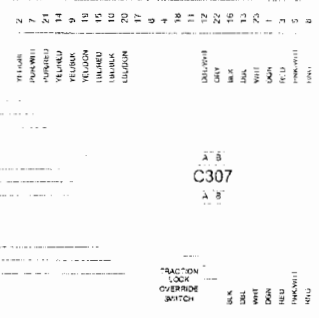

S-6718176

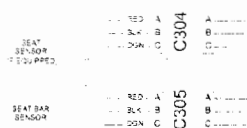
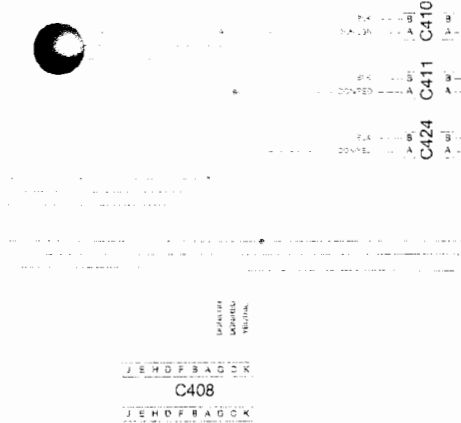

CONTROLS MODULE



MAINFRAME CONTROLLER HARNESS - 6712523



BOSS

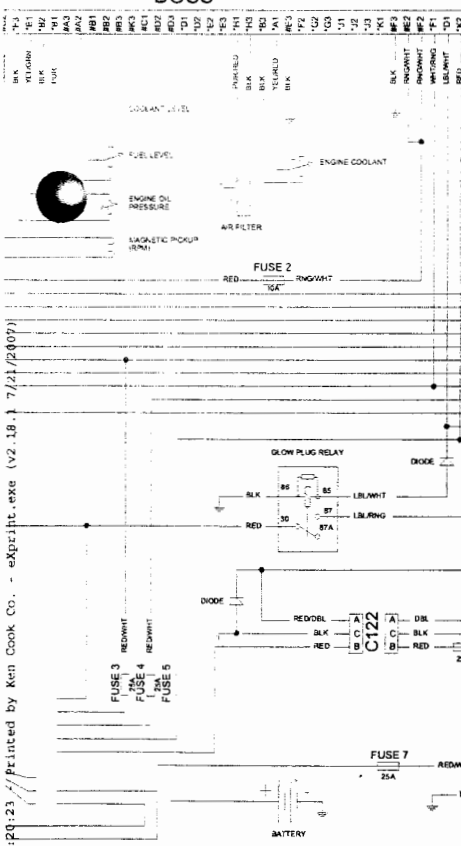

C119

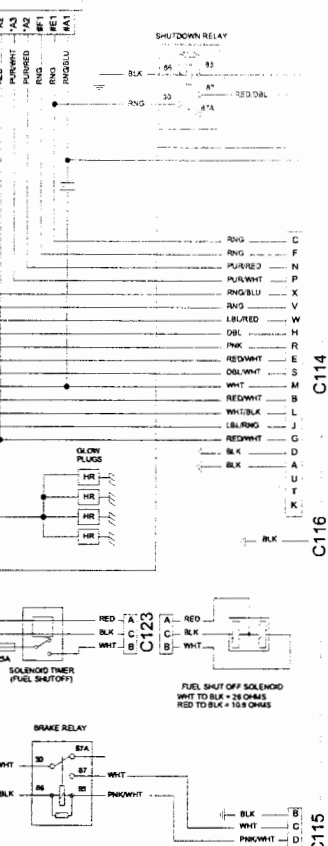

C203



CAB HARNESS (BOSS) - 6711774

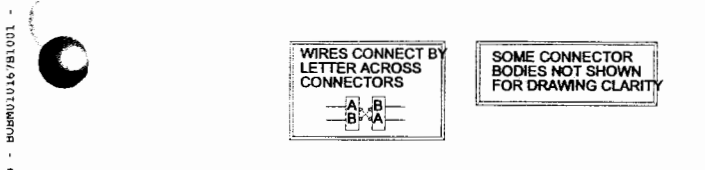
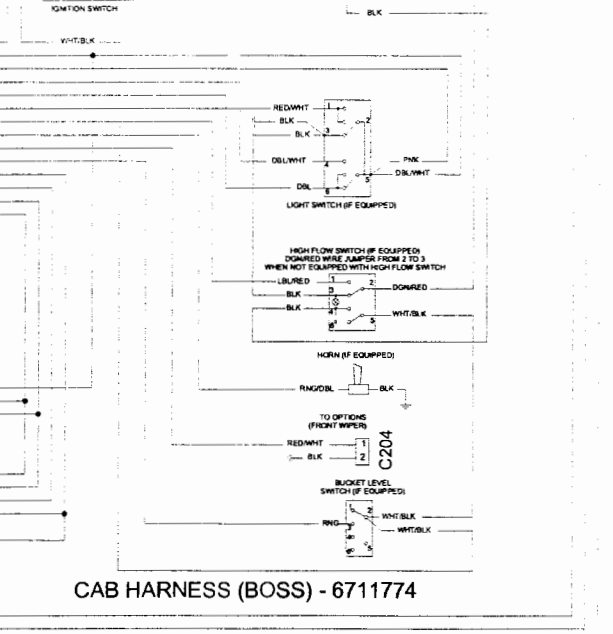

Page 4 of 4 - 09/10/2007 10:20:23 - Printed by Kim Cook Co. - eXplicit.exe (v2.18.1) 7/21/2007

753 WITHOUT BOSS - WIRING SCHEMATIC
 SN 516819275-29999
 (PRINTED OCTOBER 2000)
 MC2623

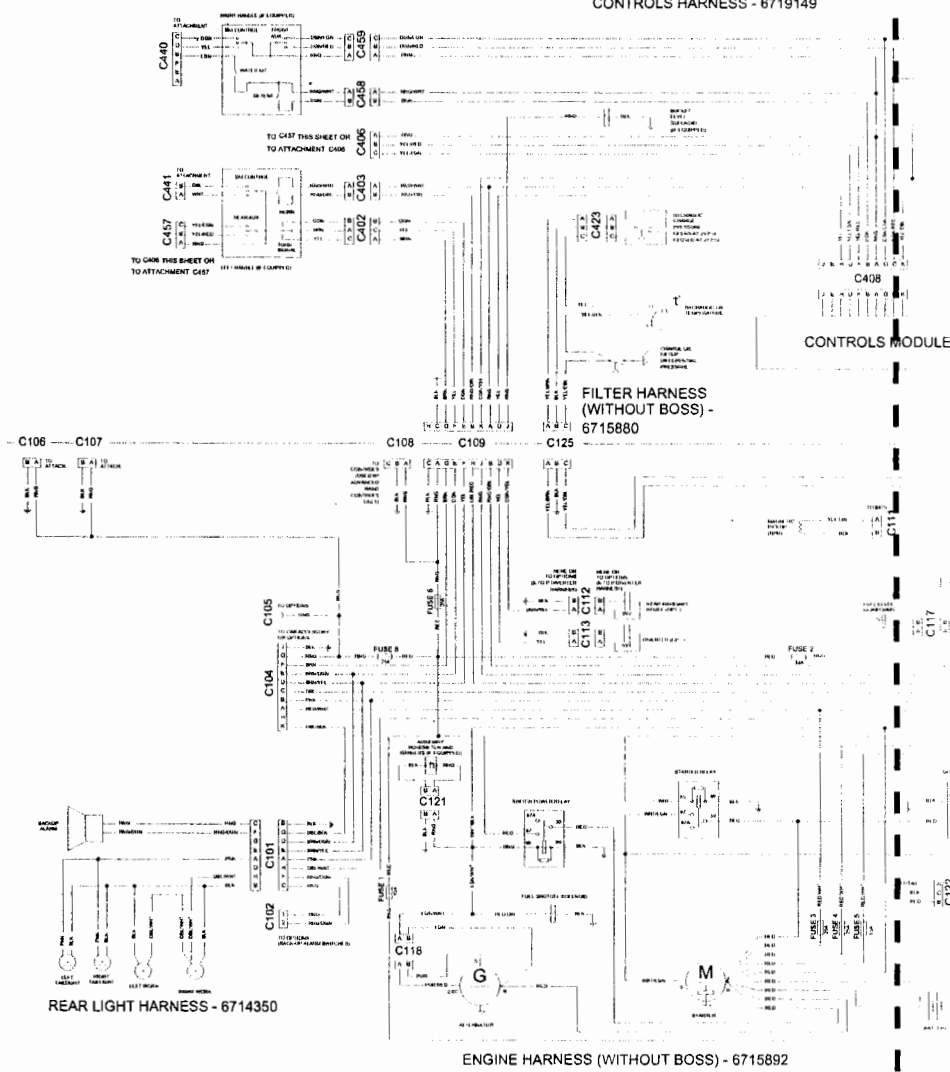

See Page - A

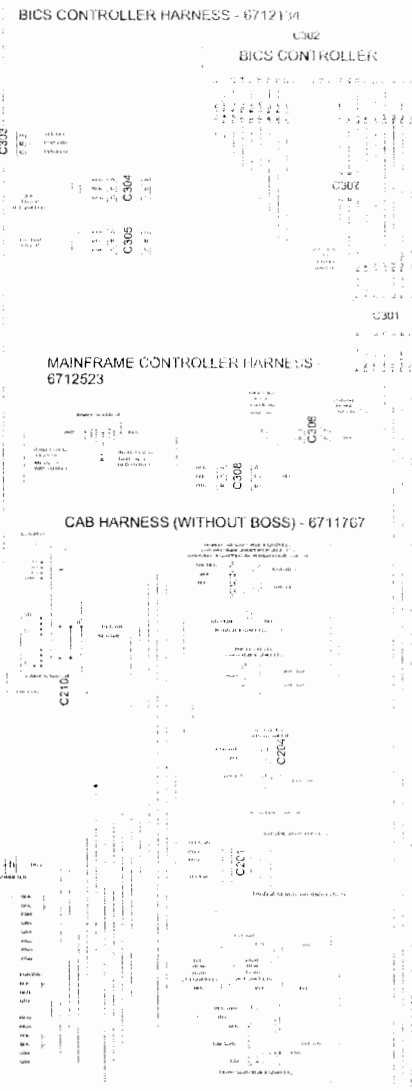

See Page - B

WIRING POINTS
 LETTER ACROSS
 CONNECTORS
 (A) (B)
 (1) (2)

SOME CONNECTOR
 BODIES NOT SHOWN
 FOR DRAWING CLARITY

RED = RED
 BROWN = BROWN
 BLUE = BLUE
 ORANGE = ORANGE
 BLACK = BLACK
 GRAY = GRAY
 GREEN = GREEN
 YELLOW = YELLOW
 WHITE = WHITE
 PURPLE = PURPLE
 TAN = TAN
 LIGHT BLUE = LIGHT BLUE
 DARK BLUE = DARK BLUE
 LIGHT GREEN = LIGHT GREEN
 DARK GREEN = DARK GREEN
 PINK = PINK
 BROWN = BROWN
 LIGHT PURPLE = LIGHT PURPLE
 GRAY = GRAY

753 WITHOUT BOSS - WIRING SCHEMATIC

S/N 515319275-29999
 PRINTED OCTOBER 2000
 MD2823

CONTROLS HARNESS - 6719149

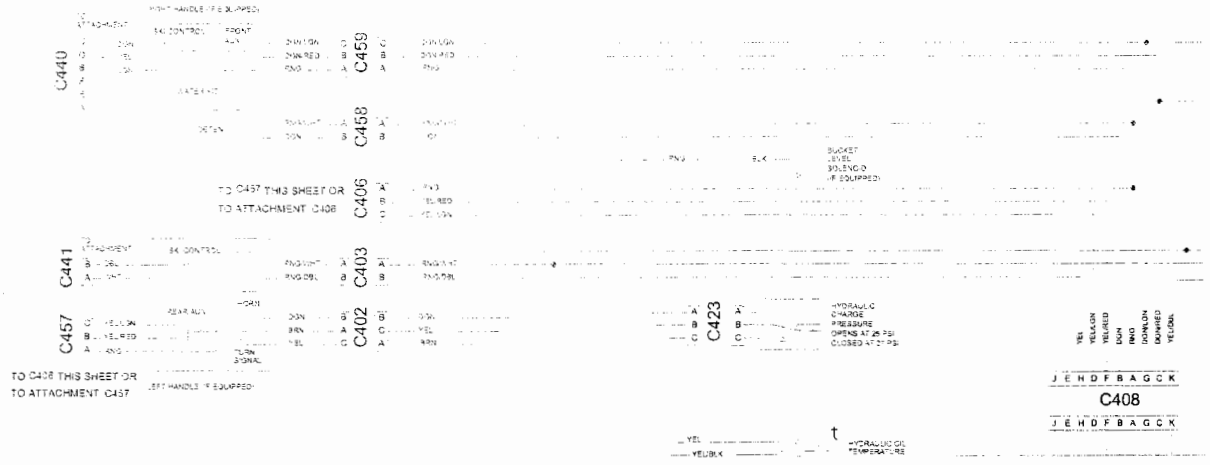

CONTROLS MODI

FILTER HARNESS (WITHOUT BOSS) - 6715880

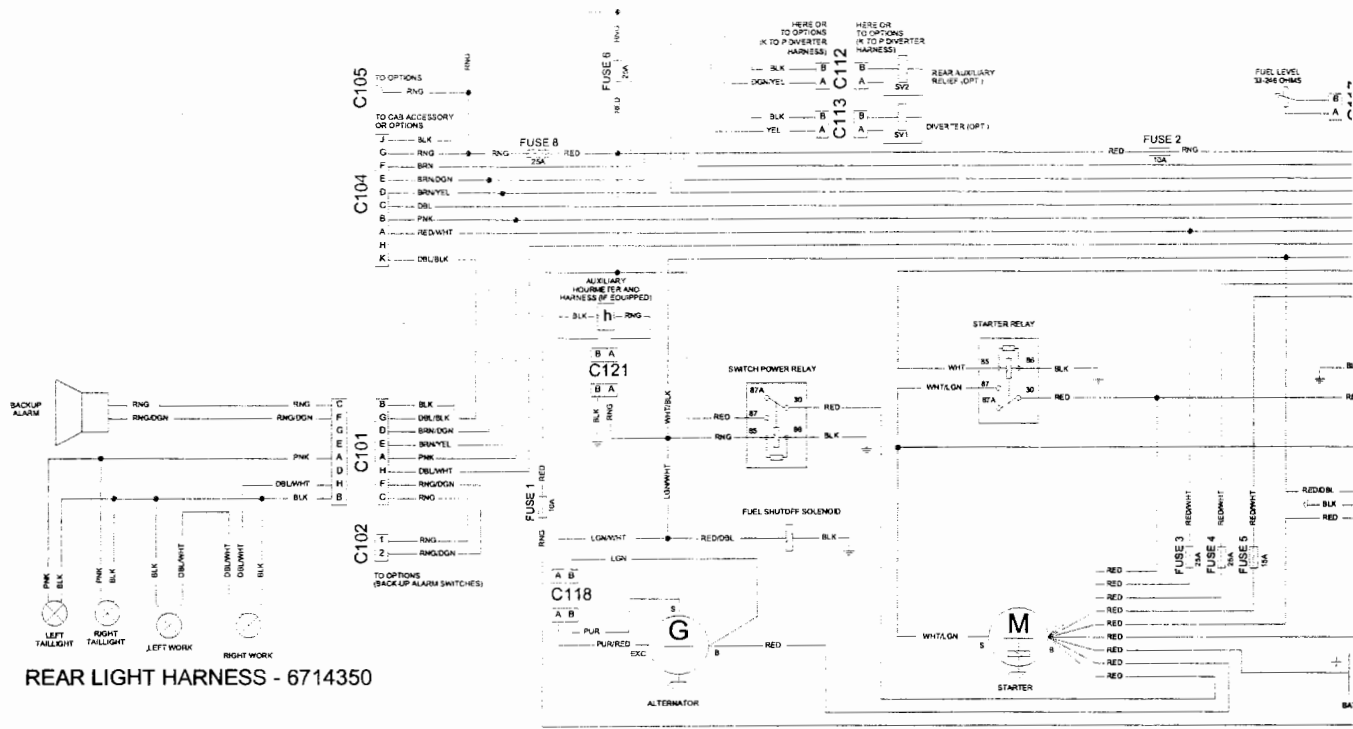
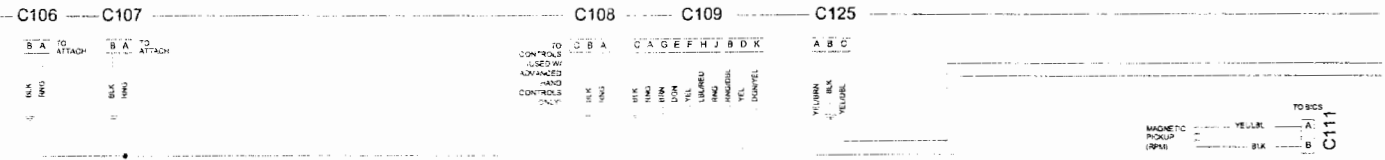

REAR LIGHT HARNESS - 6714350

ENGINE HARNESS (WITHOUT BOSS) - 6715892

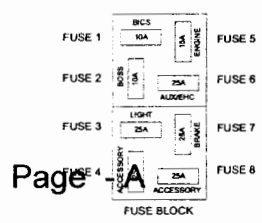

Page 4.47 - D:\BUBRUVIS\BUB001 - 07/10/2007 10:20:24 - Printed by Ken Cook Co. - ePrint.exe (v2.18.1 7/21/2007)

BICS CONTROLLER

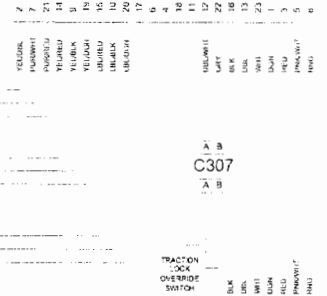

S - 6719149

TRACTION OVERRIDE SWITCH

C408

CONTROLS MODULE



MAINFRAME CONTROLLER HARNESS - 6712523

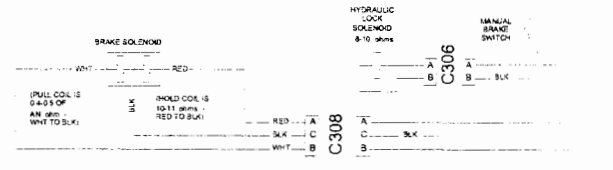

CAB HARNESS (WITHOUT BOSS) - 6711767

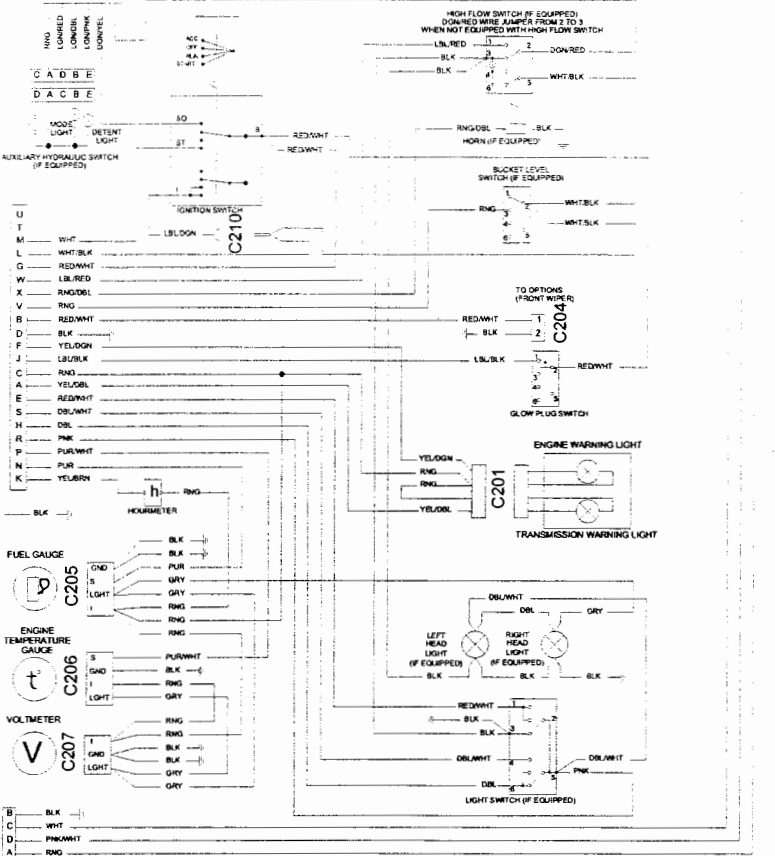

Printed by Ken Cook Co. - 09/10/2007

15892

WIRES CONNECT BY LETTER ACROSS CONNECTORS

SOME CONNECTOR BODIES NOT SHOWN FOR DRAWING CLARITY

RED = RED
 RNG = ORANGE
 BLK = BLACK
 LBL = LIGHT BLUE
 DBL = DARK BLUE
 LGN = LIGHT GREEN
 DGN = DARK GREEN
 YEL = YELLOW
 PNK = PINK
 WHT = WHITE
 BRN = BROWN
 TAN = TAN
 PUR = PURPLE
 GRN = GREY

753 BOSS - WIRING SCHEMATIC
 S/N 515810275-29999
 (PRINTED OCTOBER 2000)
 MC2624

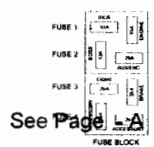
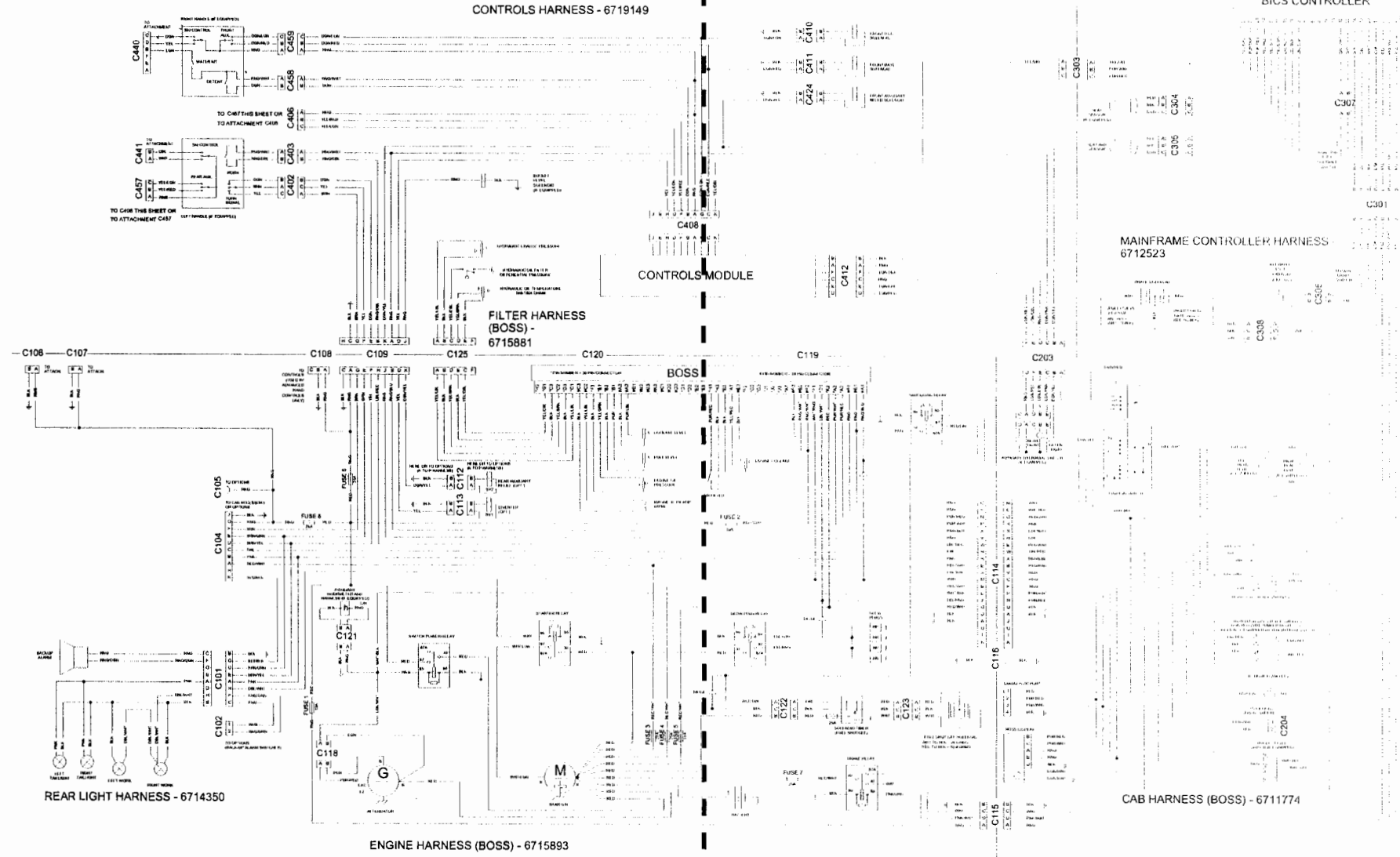

WIRES CONNECT BY LETTER ACROSS CONNECTORS
 A, B, C, D, E, F, G, H, I, J, K, L, M, N, O, P, Q, R, S, T, U, V, W, X, Y, Z

SOME CONNECTOR BODIES NOT SHOWN FOR DRAWING CLARITY

REL = RELAY
 PNC = PNEUMATIC
 BLK = BLACK
 LBL = LIGHT BLUE
 LBN = LIGHT BROWN
 LGN = LIGHT GREEN
 LGR = LIGHT GREY
 YEL = YELLOW
 PNC = PNEUMATIC
 WHT = WHITE
 BRN = BROWN
 TAN = TAN
 PUR = PURPLE
 GRY = GREY

See Page - A

See Page - B

753 BOSS - WIRING SCHEMATIC

S/N 515819275-29999
 PRINTED OCTOBER 2000
 MC2624

CONTROLS HARNESS - 6719149

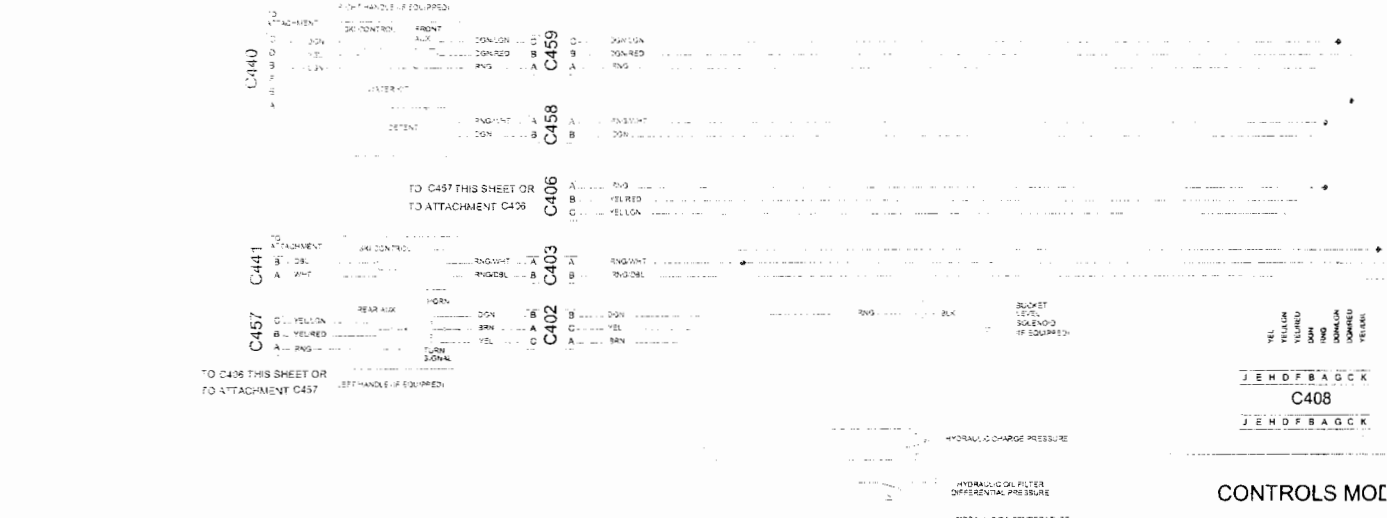

CONTROLS MOU

FILTER HARNESS (BOSS) - 6715881

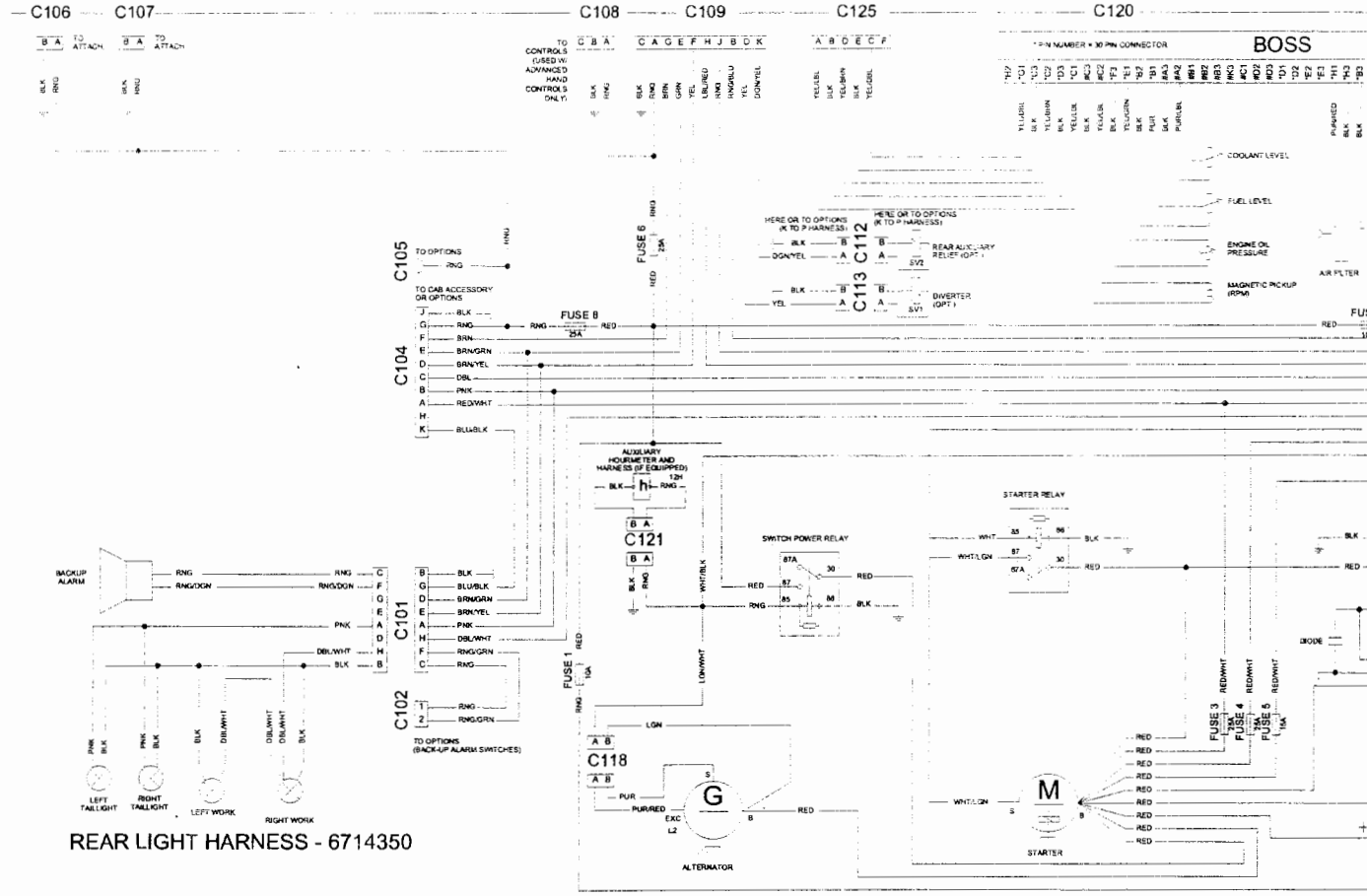

REAR LIGHT HARNESS - 6714350

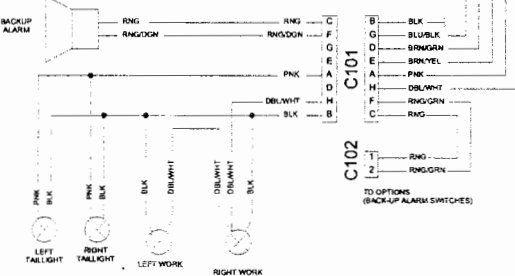

ENGINE HARNESS (BOSS) - 6715893

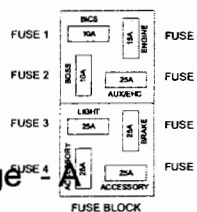
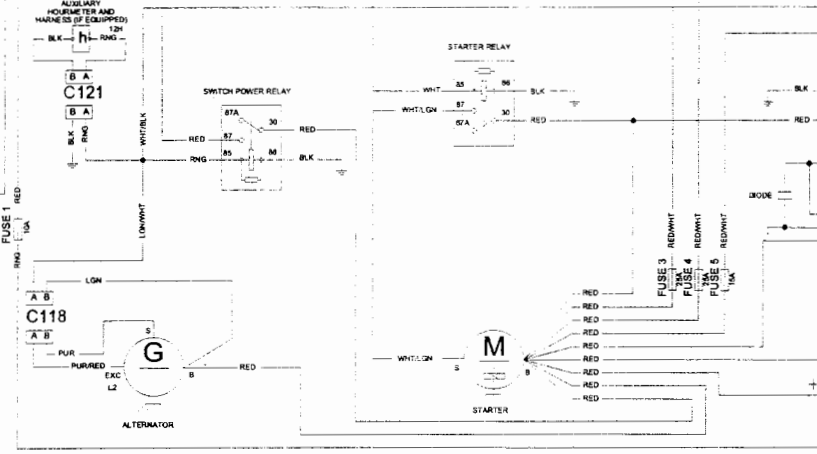

Page 433 - B08M010167B1001 - 09/10/2007 10:20:24 - Printed by Ken Cook Co. - exPrint.exe (v2.18.1 7/21/2007)

ATTACHMENT CONTROLS HARNESS - 6705901

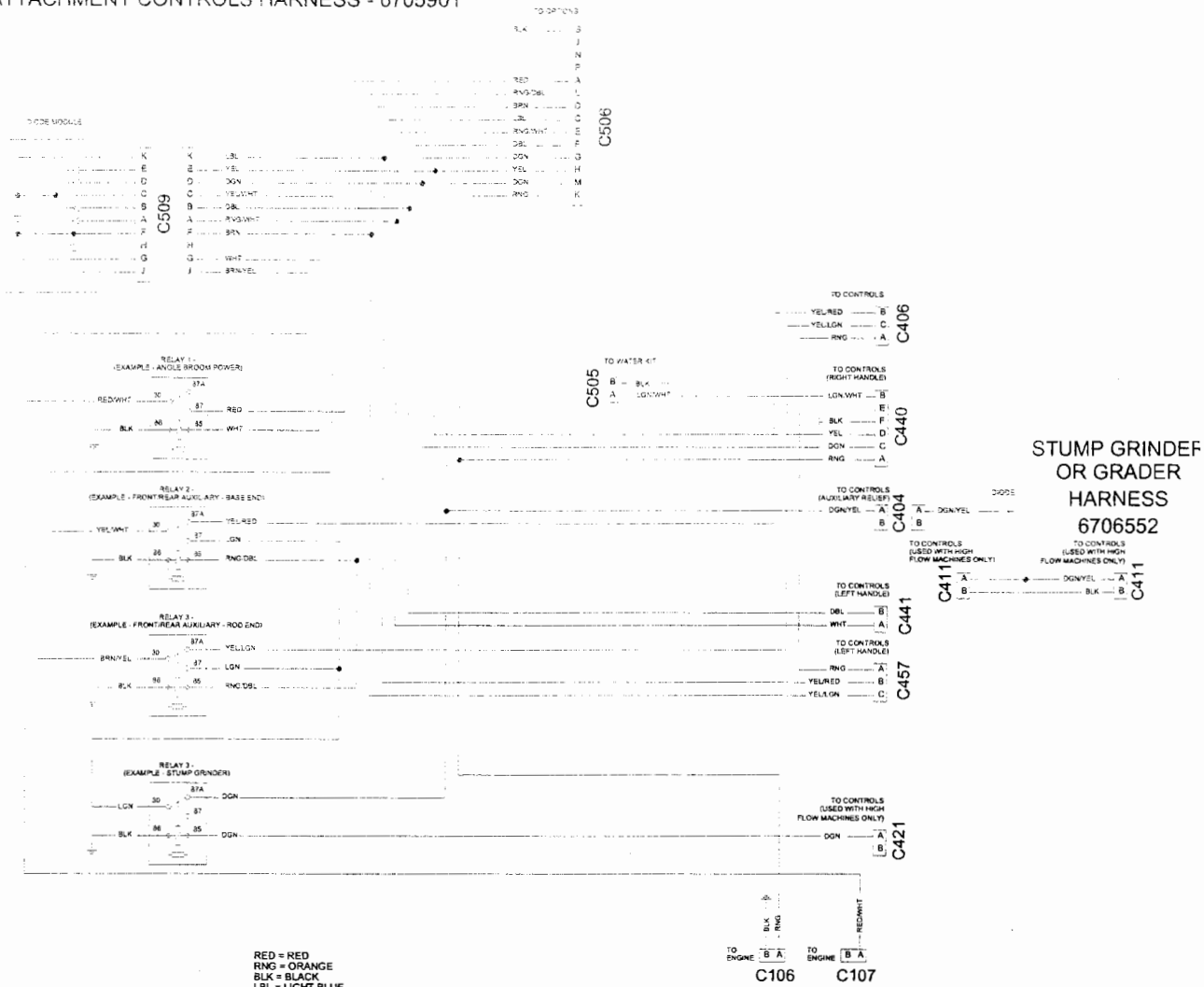

STUMP GRINDER
 OR GRADER
 HARNESS
 6706552

- RED = RED
- RNG = ORANGE
- BLK = BLACK
- LBL = LIGHT BLUE
- DBL = DARK BLUE
- LGN = LIGHT GREEN
- DGN = DARK GREEN
- YEL = YELLOW
- PNK = PINK
- WHT = WHITE
- BRN = BROWN
- TAN = TAN
- PUR = PURPLE
- GRY = GREY



SOME CONNECTOR
 BODIES NOT SHOWN
 FOR DRAWING CLARITY

753 - WIRING SCHEMATIC
 OPTIONS
 S/N 51271001 AND ABOVE
 S/N 515811001-29999
 (PRINTED OCTOBER 2006)
 MC2627

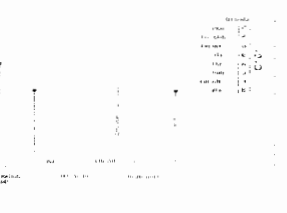
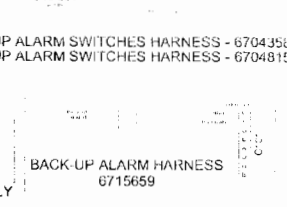
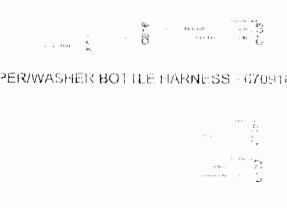
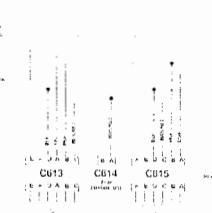
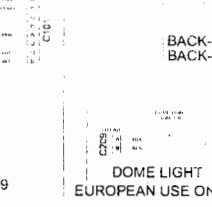
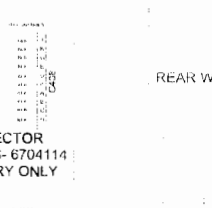
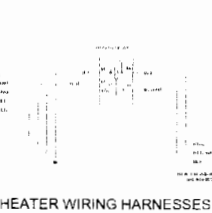
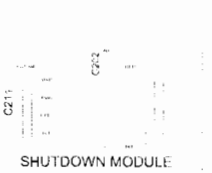
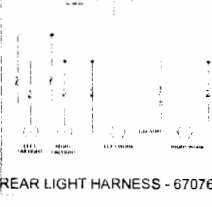
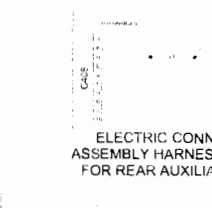
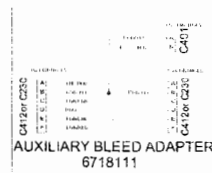
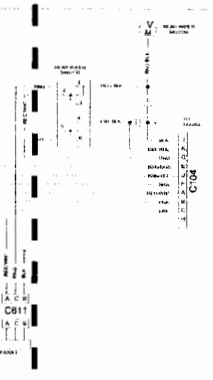
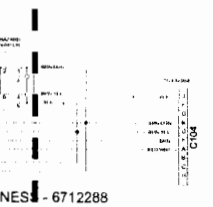
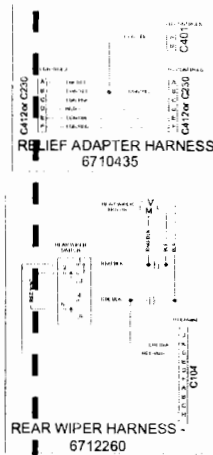
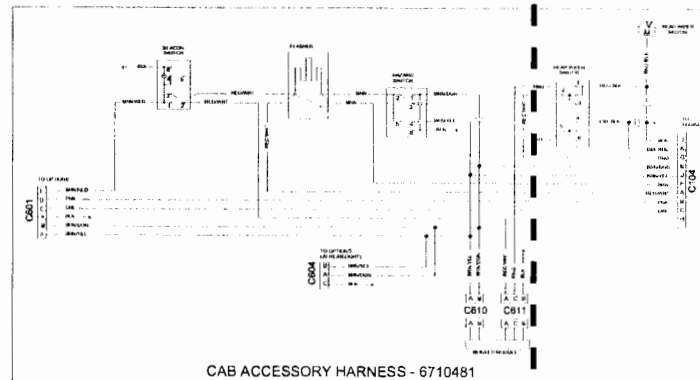
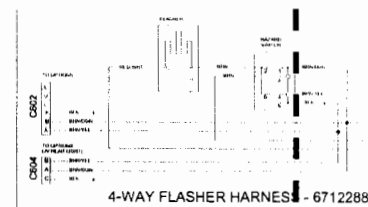
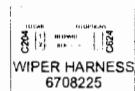
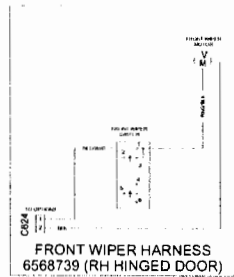
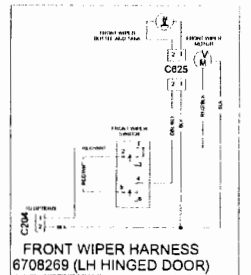
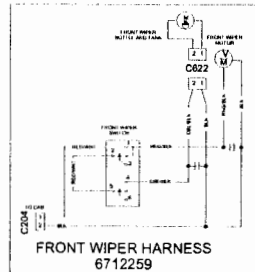
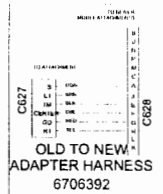
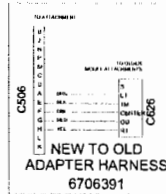
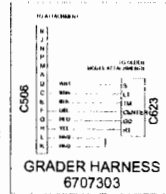
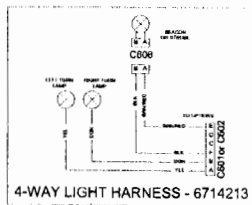
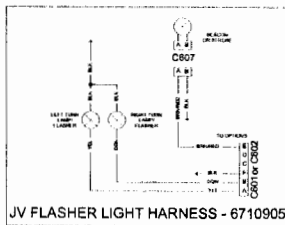
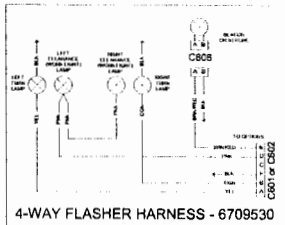
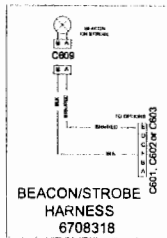
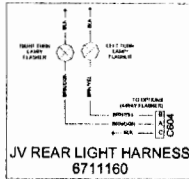

RED = RED
 ORN = ORANGE
 BLK = BLACK
 LG = LIGHT BLUE
 LBK = LIGHT BLUE
 LGN = LIGHT GREEN
 DGN = DARK GREEN
 YEL = YELLOW
 PNK = PINK
 WHI = WHITE
 BRN = BROWN
 TAN = TAN
 PUR = PURPLE
 GRN = GRAY

WIRES CONNECT BY
 LETTER ACROSS
 CONNECTORS

SOME CONNECTOR
 BODIES NOT SHOWN
 FOR DRAWING CLARITY

753 - WIRING SCHEMATIC
 OPTIONS
 S/N 512716001 AND ABOVE
 S/N 515811001-29999
 (PRINTED OCTOBER 2000)
 MC2627

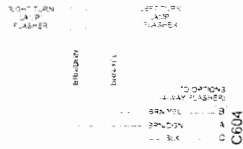

JV REAR LIGHT HARNESS
 6711160

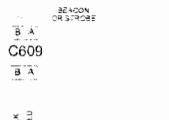

BEACON/STROBE HARNESS
 6708318

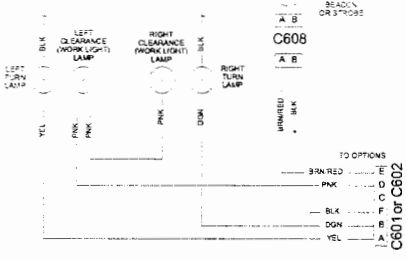

4-WAY FLASHER HARNESS - 6709530

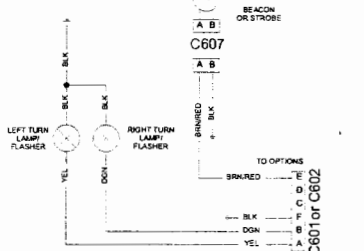

JV FLASHER LIGHT HARNESS - 6710905

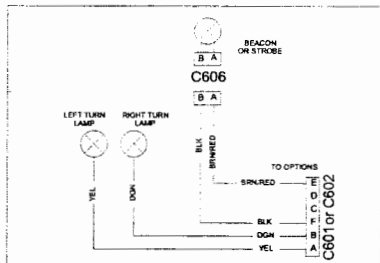

4-WAY LIGHT HARNESS - 6714213

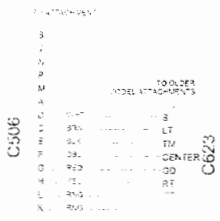

GRADER HARNESS
 6707303



NEW TO OLD ADAPTER HARNESS
 6706391



OLD TO NEW ADAPTER HARNESS
 6706392



RELIEF

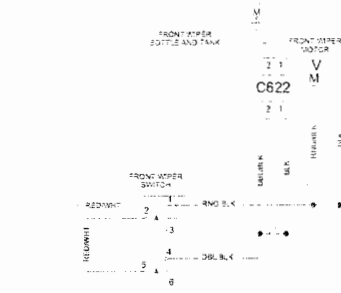

FRONT WIPER HARNESS
 6712259

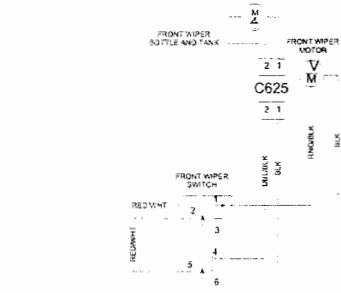

FRONT WIPER HARNESS
 6708269 (LH HINGED DOOR)



WIPER HARNESS
 6708225



FRONT WIPER HARNESS
 6568739 (RH HINGED DOOR)

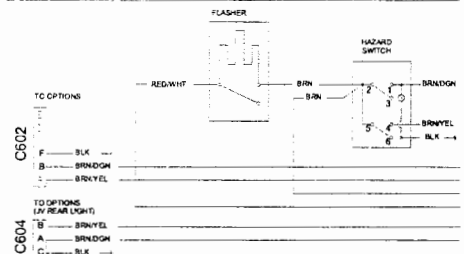

4-WAY FLASHER HARNESS - 67

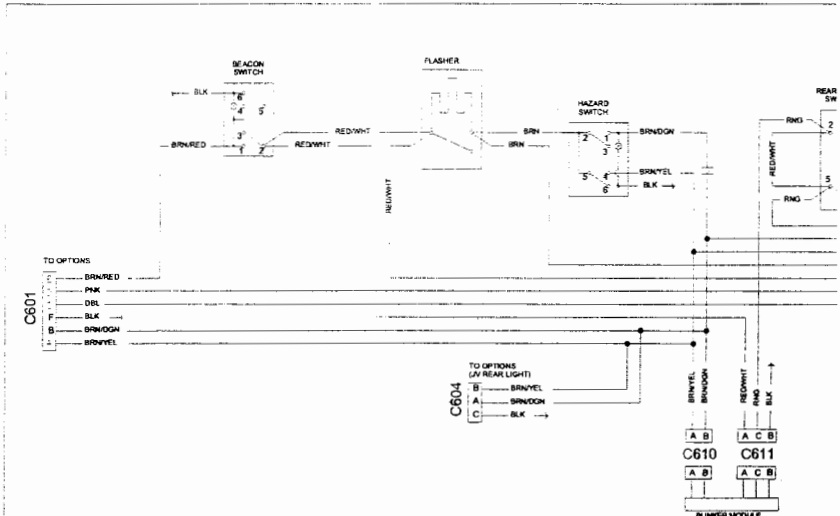

CAB ACCESSORY HARNESS - 6710481

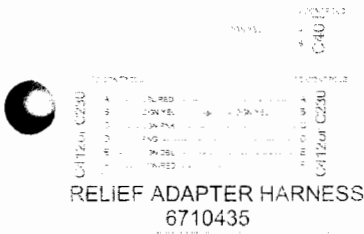

RELIEF ADAPTER HARNESS
6710435

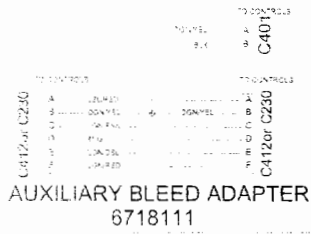

AUXILIARY BLEED ADAPTER
6718111

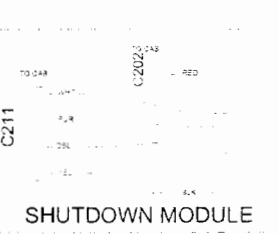

SHUTDOWN MODULE



K TO P DIVERTER HARNESS - 6716798

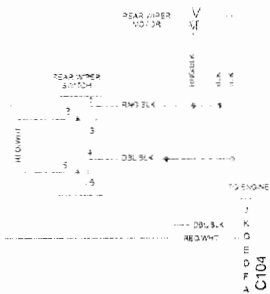

REAR WIPER HARNESS
6712260



HEATER WIRING HARNESSES - 6660894 AND 6660892

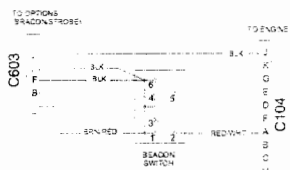
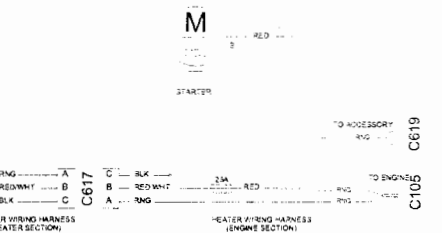

REAR WIPER/WASHER BOTTLE HARNESS - 6709164

ELECTRIC CONNECTOR
ASSEMBLY HARNESS- 6704114
FOR REAR AUXILIARY ONLY

EACON/STROBE HARNESS -
6712258

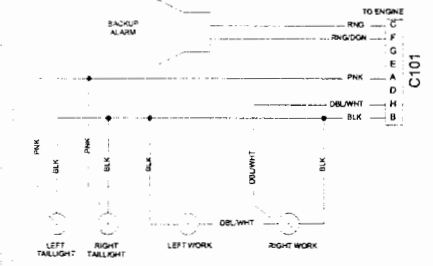

REAR LIGHT HARNESS - 6707669

BACK-UP ALARM SWITCHES HARNESS - 6704358
BACK-UP ALARM SWITCHES HARNESS (ENGINE SECTION) - 6704815



BACK-UP ALARM HARNESS
6715659

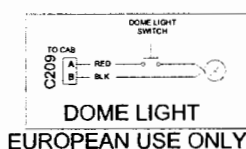

DOMELIGHT
EUROPEAN USE ONLY

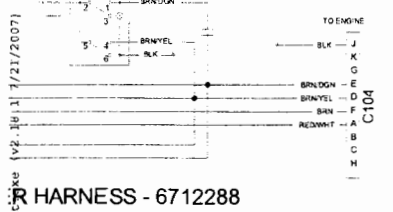

BUNKER MODULE HARNESS - 6712288

09/10/2007 10:20:25 - Printed by Ken Cook Co. - expires 7/21/2007
 481
 page 4 of 3

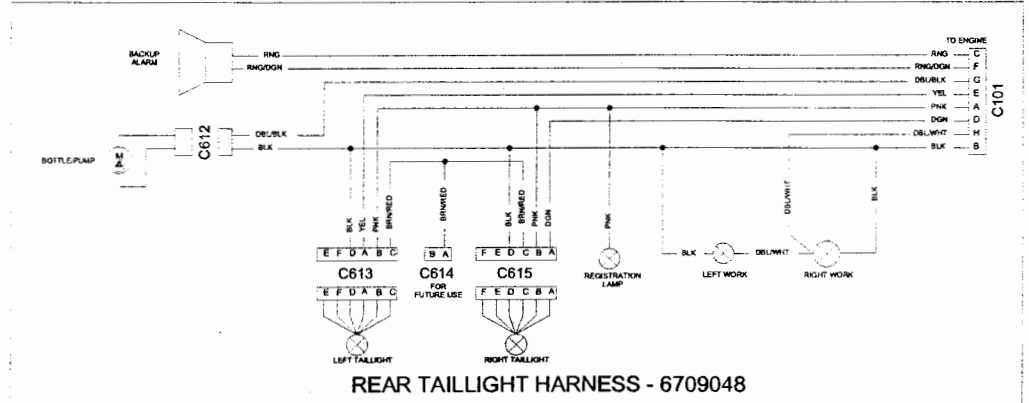

REAR TAILLIGHT HARNESS - 6709048

RED = RED
 RNG = ORANGE
 BLK = BLACK
 LBL = LIGHT BLUE
 DBL = DARK BLUE
 LGN = LIGHT GREEN
 DGM = DARK GREEN
 YEL = YELLOW
 PNK = PINK
 WHT = WHITE
 BRN = BROWN
 TAN = TAN
 PUR = PURPLE
 GRY = GREY

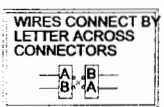

SOME CONNECTOR BODIES NOT SHOWN FOR DRAWING CLARITY

753 WIRING SCHEMATIC OPTIONS

S/N 512716001 AND ABOVE
S/N 515811001-29999
(PRINTED OCTOBER 2000)
V-0053

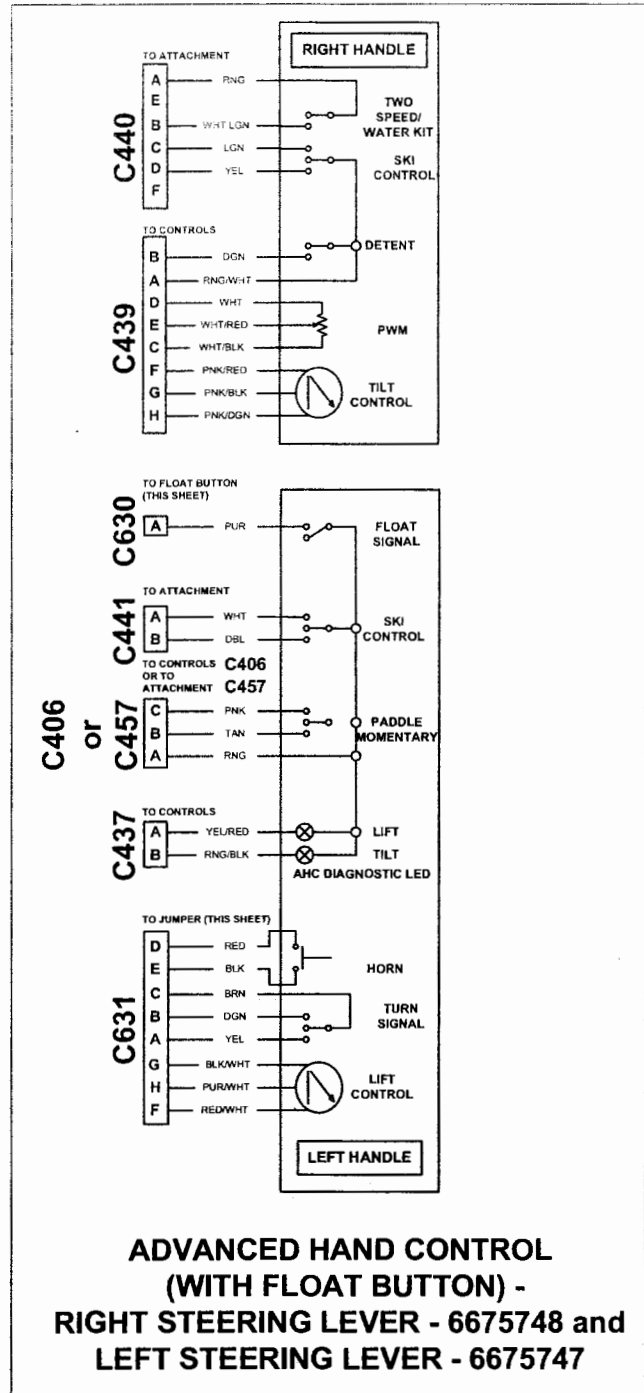
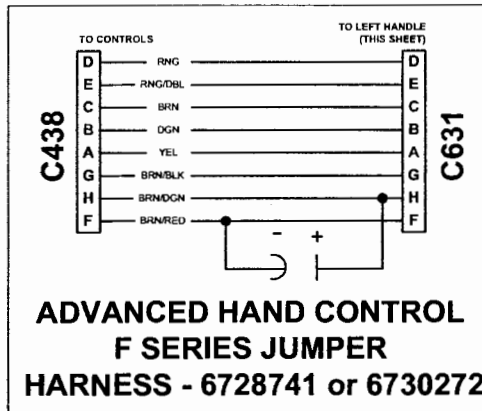

RED = RED
RNG = ORANGE
BLK = BLACK
LBL = LIGHT BLUE
DBL = DARK BLUE
LGN = LIGHT GREEN
DGN = DARK GREEN
YEL = YELLOW
PNK = PINK
WHT = WHITE
BRN = BROWN
TAN = TAN
PUR = PURPLE
GRY = GRAY

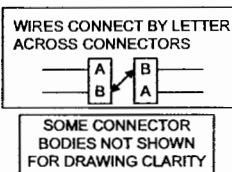

BATTERY FEED 1000-1999 RED, RED/WHT, RNG
GROUND 2000-2999 BLK
MONITORING 3000-3999 LBL
HYDRAULIC 4000-4999 LGN
ATTACHMENT CONTROLS 5000-5999 YEL
LIGHTS 6000-6999 PNK
ACCESSORIES 7000-7999 WHT
ENGINE 8000-8999 TAN
COMMUNICATION 9000-9999 PUR

753 WIRING SCHEMATIC OPTIONS

S/N 512716001 AND ABOVE
S/N 515811001-29999
(PRINTED OCTOBER 2000)
V-0053

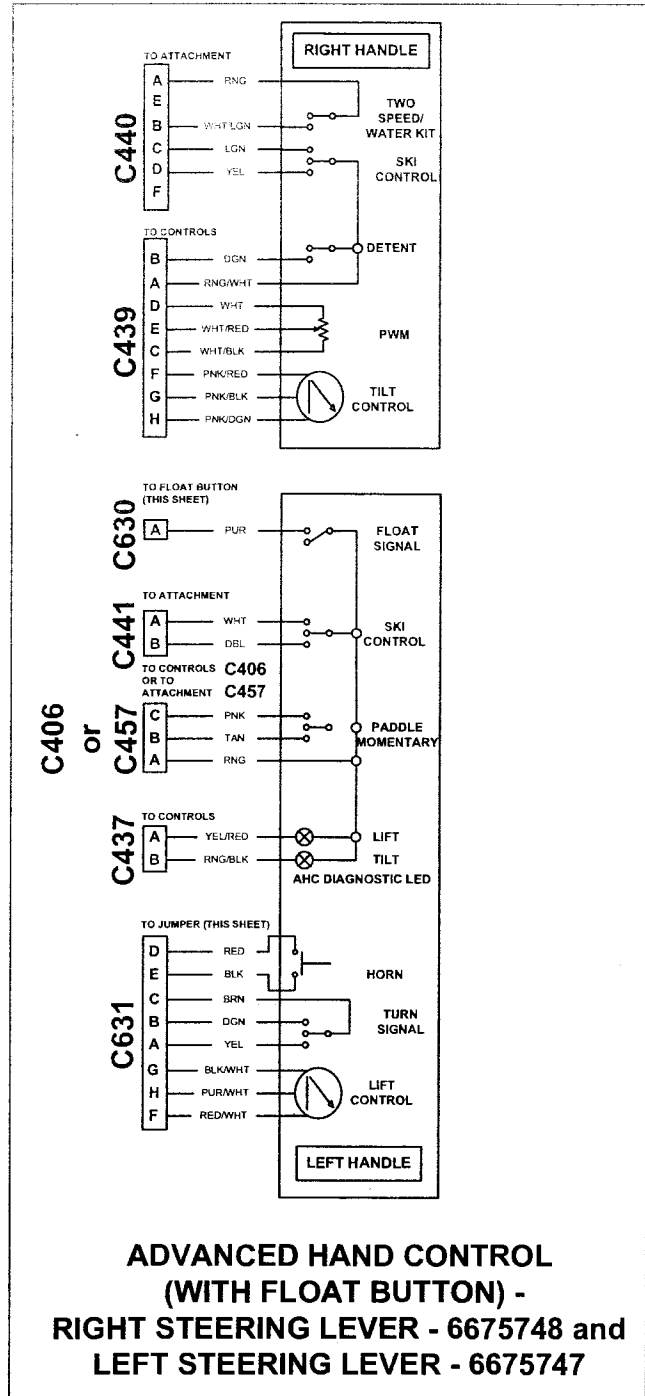
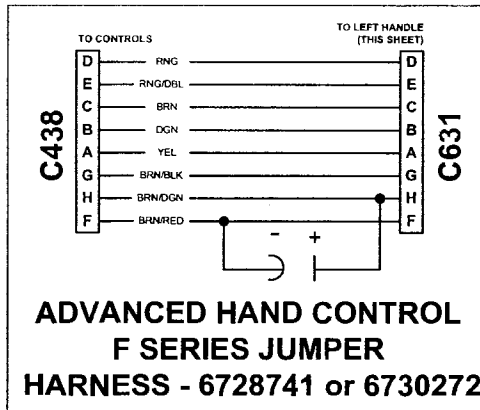

RED = RED
RNG = ORANGE
BLK = BLACK
LSL = LIGHT BLUE
DBL = DARK BLUE
LGN = LIGHT GREEN
DGN = DARK GREEN
YEL = YELLOW
PNK = PINK
WHT = WHITE
BRN = BROWN
TAN = TAN
PUR = PURPLE
GRY = GRAY

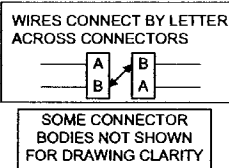

BATTERY FEED 1000-1999 RED, RED/WHT, RNG
GROUND 2000-2999 BLK
MONITORING 3000-3999 LBL
HYDRAULIC 4000-4999 LGN
ATTACHMENT CONTROLS 5000-5999 YEL
LIGHTS 6000-6999 PNK
ACCESSORIES 7000-7999 WHT
ENGINE 8000-8999 TAN
COMMUNICATION 9000-9999 PUR

TROUBLESHOOTING

Chart

The following troubleshooting chart is provided for assistance in locating and correcting problems. Many of the recommended procedures must be done by authorized Bobcat Service Personnel only.

WARNING

Instructions are necessary before operating or servicing machine. Read and understand the Operation & Maintenance Manual, Handbook and signs (decals) on machine. Follow warnings and instructions in the manuals when making repairs, adjustments or servicing. Check for correct function after adjustments, repairs or service. Untrained operators and failure to follow instructions can cause injury or death.

W-2003-0199

PROBLEM	CAUSE
Battery will not take a charge.	1, 2, 3, 4, 5
Alternator will not charge.	1, 2, 5
Starter will not turn the engine.	2, 3, 4, 6, 7, 8, 9

KEY TO CORRECT THE CAUSE

1. Alternator belt is loose or damaged.
2. Battery connections are dirty or loose.
3. Battery is damaged.
4. The ground connection is not making a good contact.
5. The alternator is damaged.
6. The engine is locked.
7. The starter is damaged.
8. The wiring or the solenoid is damaged.
9. Check the fuses.

Copyright © 2000 Bobcat Company. All rights reserved. Printed in the USA. 753-000001

ELECTRICAL SYSTEM INFORMATION

Description

The loader has a 12 volt, negative ground alternator charging system. The electrical system is protected by fuses (Item 1) [A] located in the engine compartment. The fuses will protect the electrical system when there is an electrical overload. The reason for the overload must be found before starting the engine again.

IMPORTANT

Do Not use silicone base sprays and/or sealants on harness connectors or components.

I-2123-0387

Fuse Location (Standard & BOSS® Option)

The electrical system for loaders is protected by eight fuses located in the fuse block (Item 1) [B]. Remove the fuse block cover to access the fuses.

The decal inside the rear door specifies the fuse sizes used in various loader circuits [C] & [D].

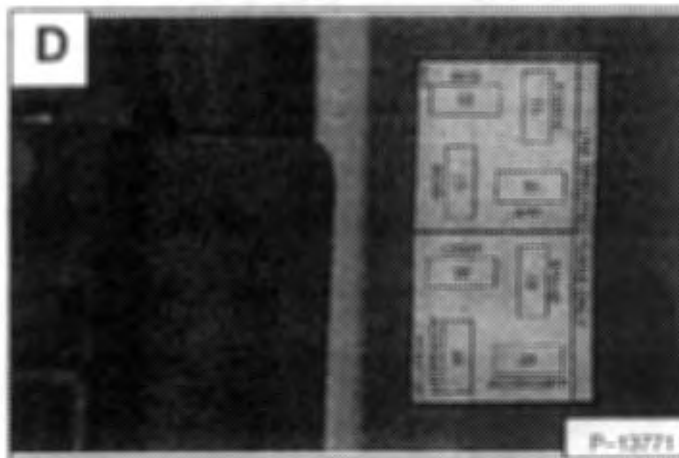
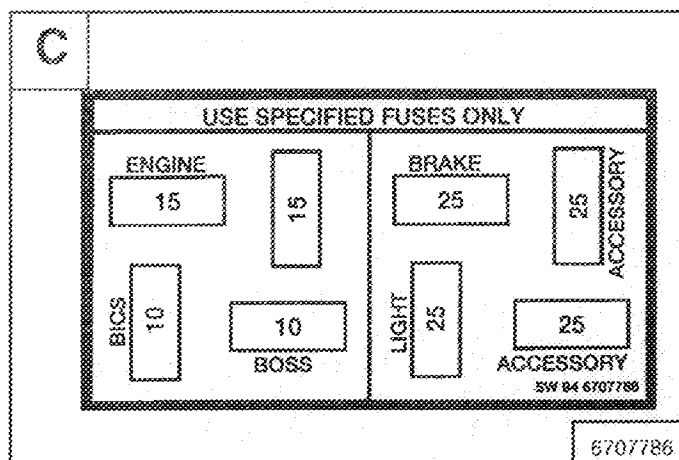
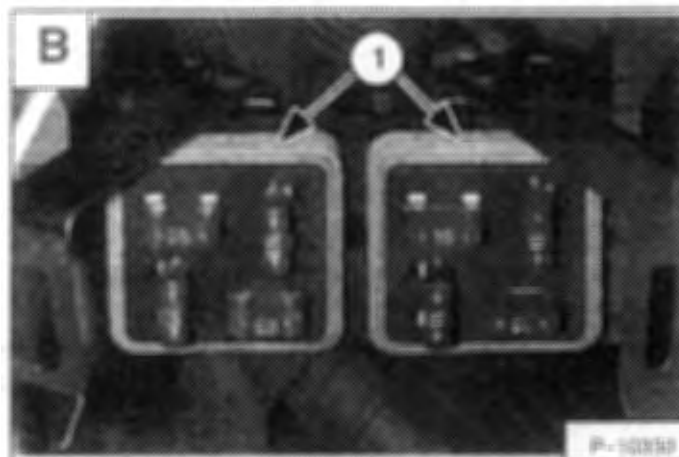
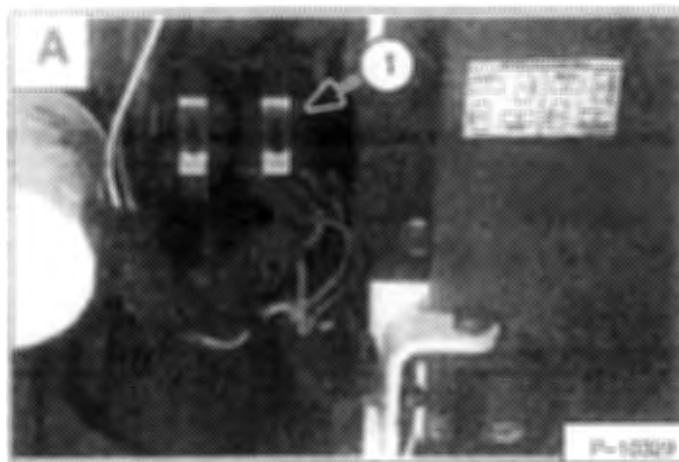

BATTERY

Removal And Installation

WARNING

Batteries contain acid which burns eyes and skin on contact. Wear goggles, protective clothing and rubber gloves to keep acid off body.

In case of acid contact, wash immediately with water. In case of eye contact get prompt medical attention and wash eye with clean, cool water for at least 15 minutes.

If electrolyte is taken internally drink large quantities of water or milk! DO NOT induce vomiting. Get prompt medical attention.

W-2065-1296

Open the rear door.

Disconnect the negative(-) battery cable [A] from the battery.

Disconnect the positive (+) cable [B] from the battery.

Remove the battery holddown clamp (Item 1) [C].

Remove the battery from the loader [D].

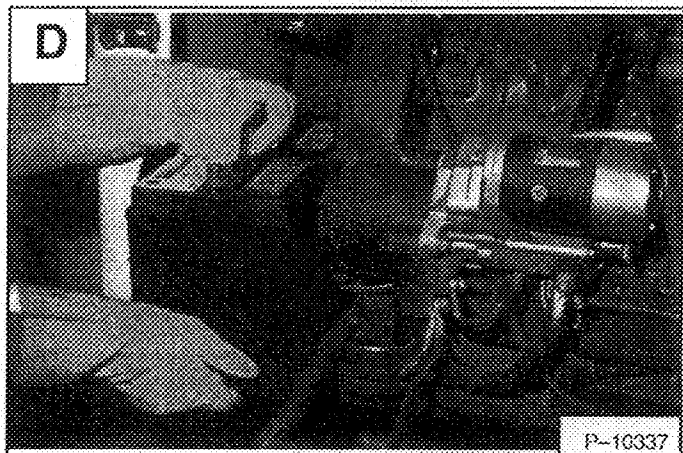
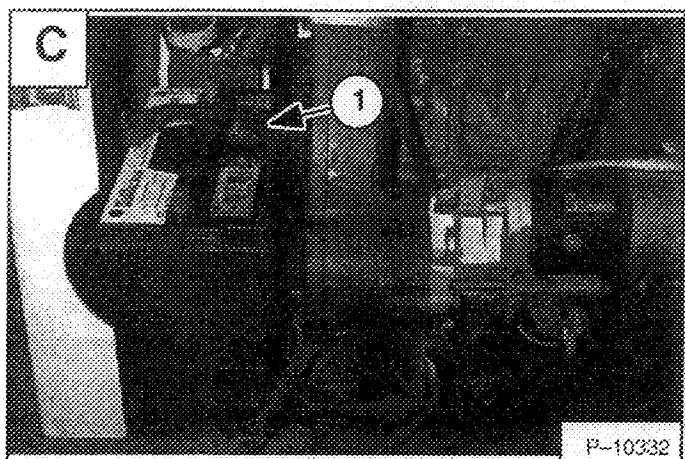
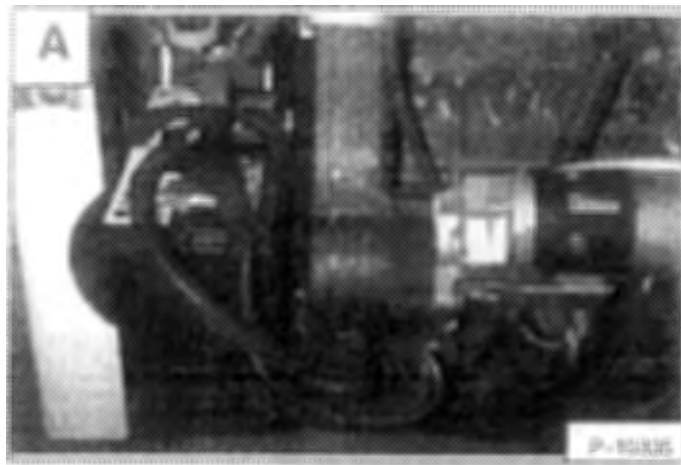

BATTERY (Cont'd)

Removal And Installation (Cont'd)

Installation:

Always clean the terminals and cable ends when installing a new battery [A] & [B].

When installing the battery in the loader, do not touch any metal parts with the battery terminal posts.

Connect and tighten the battery cables. Connect the negative (-) cable last to prevent sparks.

Install the battery holddown clamp.

Servicing The Battery

WARNING

Batteries contain acid which burns eyes and skin on contact. Wear goggles, protective clothing and rubber gloves to keep acid off body.

In case of acid contact, wash immediately with water. In case of eye contact get prompt medical attention and wash eye with clean, cool water for at least 15 minutes.

If electrolyte is taken internally drink large quantities of water or milk! DO NOT induce vomiting. Get prompt medical attention.

W-2065-1296

The battery cables must be clean and the connections tight. Remove acid or corrosion from the battery and cables with a sodium bicarbonate (baking soda) and water solution [C].

Clean the terminals and cable ends as shown in figure [A] and [B].

Check the electrolyte level in the battery.

Add distilled water as needed. Put battery saver P/N (6664458) or grease on the battery terminals and cable ends to prevent corrosion.

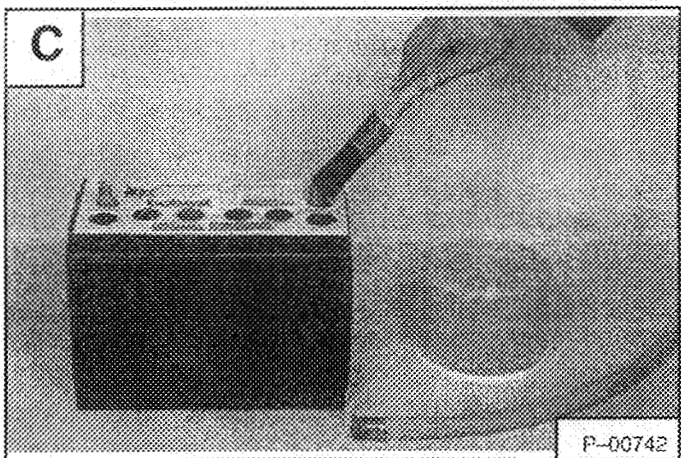

BATTERY (Cont'd)

Using A Booster Battery (Jump Starting)

⚠ WARNING

Keep arcs, sparks, flames and lighted tobacco away from batteries. When *jumping* from booster battery make final connection (negative) at engine frame.

Do not jump start or charge a frozen or damaged battery. Warm battery to 60°F. (16°C.) before connecting to a charger. Unplug charger before connecting or disconnecting cables to battery. Never lean over battery while boosting, testing or charging.

Battery gas can explode and cause serious injury.

W-2065-1295

Batteries contain acid which burns eyes and skin on contact. Wear goggles, protective clothing and rubber gloves to keep acid off body.

In case of acid contact, wash immediately with water. In case of eye contact get prompt medical attention and wash eye with clean, cool water for at least 15 minutes.

If electrolyte is taken internally drink large quantities of water or milk! DO NOT induce vomiting. Get prompt medical attention.

W-2065-1295

If it is necessary to use a booster battery to start the engine, **BE CAREFUL!** There must be one person in the operator's seat and one person to connect and disconnect the battery cables.

The key switch must be in the OFF position. The booster battery must be 12 volt.

Connect the end of the first cable (Item 1) [A] to the positive (+) terminal of the booster battery. Connect the other end of the same cable (Item 1) [B] to the positive terminal on the loader starter (battery for early models).

Connect the end of the second cable (Item 2) [A] to the negative (-) terminal of the booster battery. Connect the other end of the same cable (Item 2) [B] to the engine.

Keep cables away from moving parts. Start the engine.

After the engine has started, remove the ground (-) cable (Item 2) [B] first. Remove the cable from the positive terminal on the loader battery.

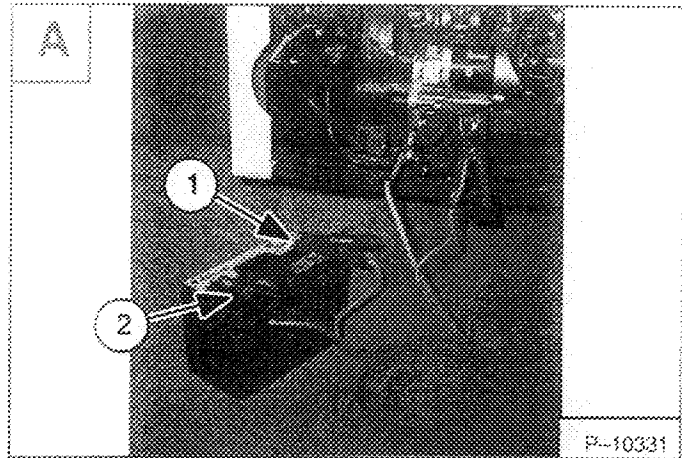

P-10331

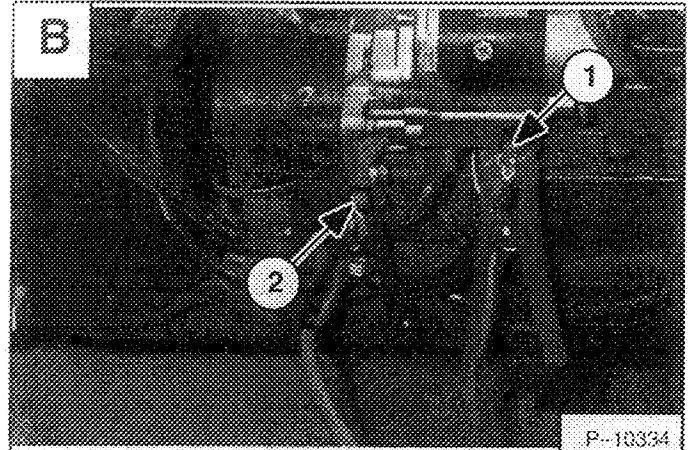

P-10334

IMPORTANT

Damage to the alternator can occur if:

- Engine is operated with battery cables disconnected.
- Battery cables are connected when using a fast charger or when welding on the loader (Remove both cables from the battery).
- Extra battery cables (booster cables) are connected wrong.

I-2023-1285

ALTERNATOR

Test the alternator as follows:

- a. Alternator Output Test
- b. Rectifier (Diode) Test
- c. Alternator Regulator Test

Alternator Output Test

Lift and block the loader. (See Page 1-1.)

Disconnect the negative (-) cable from the battery.

NOTE: The photo's may be different but the procedure is the same for all models.

Disconnect the red wire (Item 1) [B] from the alternator. Connect that wire to the negative (-) side of the ammeter.

Connect the positive (+) side of the ammeter to the output terminal on the alternator (Item 2) [B].

Disconnect the fuel stop solenoid connector.

Connect the negative (-) cable to the battery.

Turn on the lights and crank the engine for 30 seconds to discharge the battery.

Connect the fuel stop solenoid, start the engine and run at 2600 RPM.

The ammeter reading should be between 45-55 amps. at 2600 RPM.

If the reading is low, remove the screws and pull the regulator cover away from the alternator.

Rectifier (Diode) Test

The alternator is removed from the loader for clarity purposes [C].

Disconnect the negative (-) cable from the battery.

Install the wires in their original location on the back of the alternator.

Connect a jumper wire (Item 1) [C] to the alternator output terminal and the regulator terminal.

Connect the battery negative (-) cable.

Start the engine and run at 2600 RPM.

If the reading is within 45-55 amps. at 2600 RPM replace the rectifier (diode) assembly or replace the alternator.

If the reading is low, do the Alternator Regulator Test.

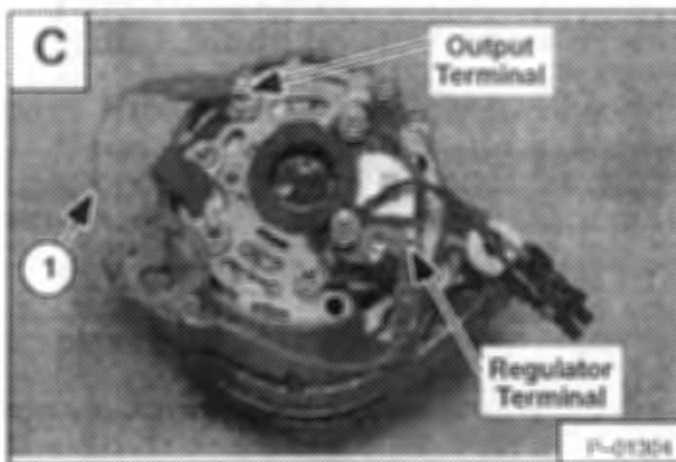
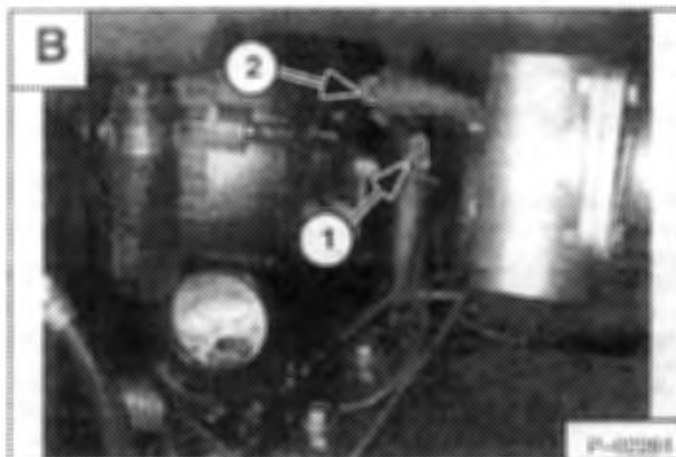
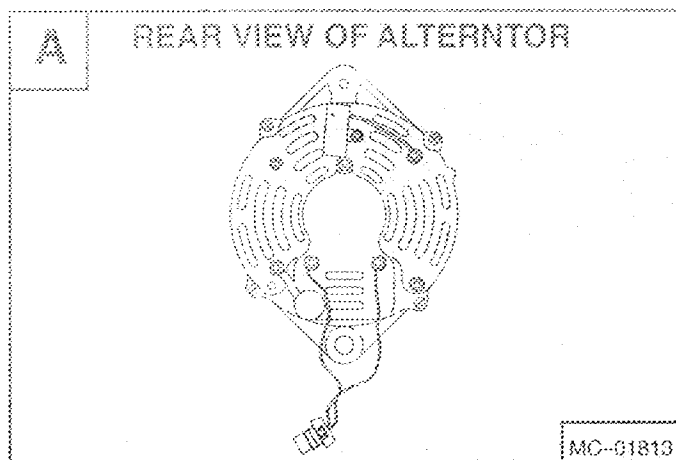

! WARNING

Put jackstands under the front axles and rear corners of the frame before running the engine for service. Failure to use jackstands can allow the machine to fall or move and cause injury or death.

W-2017-0286

ALTERNATOR (Cont'd)

Alternator Regulator Test

WARNING

When an engine is running in an enclosed area, fresh air must be added to avoid concentration of exhaust fumes. If the engine is stationary, vent the exhaust outside. Exhaust fumes contain odorless, invisible gases which can kill without warning.

W-2050-1285

Connect the positive (+) voltmeter lead to the positive (+) battery terminal [A].

Connect the negative (-) voltmeter lead to the negative (-) battery terminal [A].

Start the engine and run at 1500-2000 RPM.

The voltmeter should read between 13.9-14.7 volts.

If the reading is low stop the engine and disconnect the battery negative (-) cable.

The alternator is removed from the loader for clarity purposes [B].

Remove the wires from the back of the alternator.

Remove the regulator cover from the back of the alternator.

Install the wires on the back of the alternator.

Connect a jumper wire (Item 1) [B] from the brush terminal to the ground stud.

Connect the negative (-) battery cable and start the engine. Run at 1500 RPM.

If the voltmeter reading is 14.5 or above replace the regulator.

If the voltmeter reading is below 14.5, repair or replace the alternator.

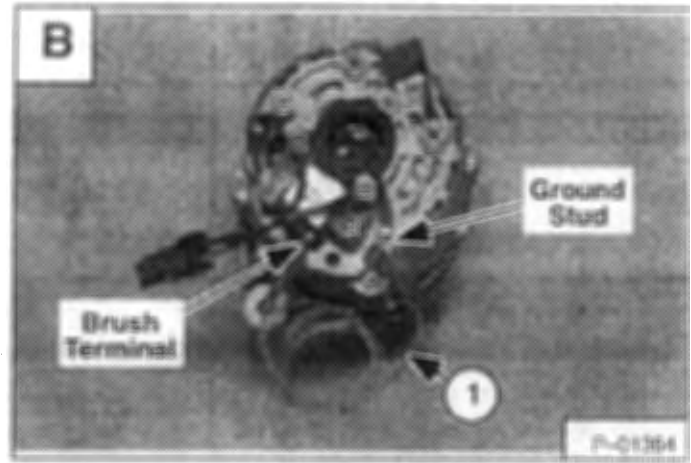
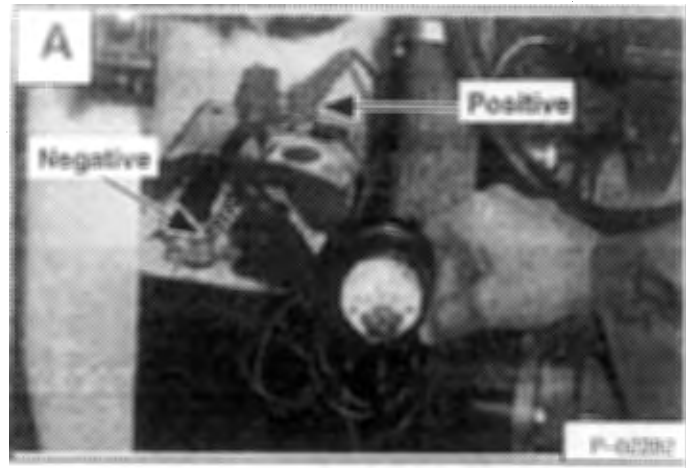

ALTERNATOR (Cont'd)

Removal And Installation

Place jackstands under the rear corners of the loader.

Raise the lift arms and install an approved lift arm support device. (See Page 1-1.)

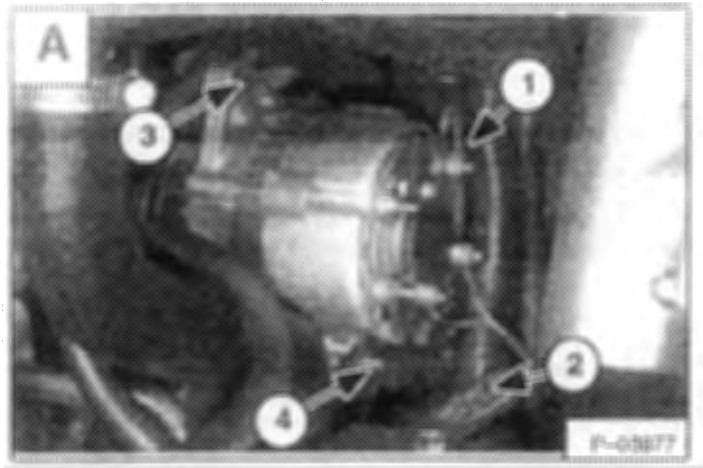

⚠ WARNING

Never work on a machine with the lift arms up unless the lift arms are secured by an approved lift arm support device. Failure to use an approved lift arm support device can allow the lift arms or attachment to fall and cause injury or death.

W-2059-0598

Raise the operator cab. (See Page 1-1.)

Disconnect the negative (-) cable from the battery.

Disconnect the red wire (Item 1) [A] from the alternator which comes from the battery.

Disconnect the wiring harness connector (Item 2) [A] from the alternator.

Remove the adjustment bolt (Item 3) [A] from the mounting bracket.

Remove the alternator belt from the alternator pulley.

Remove the mounting bolt (Item 4) [A].

Adjusting The Alternator Belt

Stop the engine.

Raise the operator cab. (See Page 1-1.)

Loosen the alternator mounting bolt (Item 4) [A].

Loosen the adjustment bolt (Item 3) [A].

Move the alternator until the belt has 5/16 inch (8,0 mm) movement at the middle of the belt span with 15 lbs. (66 N) of force.

Tighten the adjustment bolt and mounting bolt.

Lower the operator cab.

IMPORTANT

Damage to the alternator can occur if:

- Engine is operated with battery cables disconnected.
- Battery cables are connected when using a fast charger or when welding on the loader (Remove both cables from the battery).
- Extra battery cables (booster cables) are connected wrong.

I-2023-1285

ALTERNATOR (Cont'd)

Disassembly And Inspection

Disassemble the alternator. (See Parts Identification Fig. [A].)

Remove the regulator cover and regulator.

Remove the four bolts holding halves together.

Pry the halves apart (use a press if needed).

Use a soft jaw vise to hold rotor while removing pulley nut.

Remove front case half from the rotor using a plastic hammer or press.

Unsolder the stator leads from the rectifier. Remove the stator.

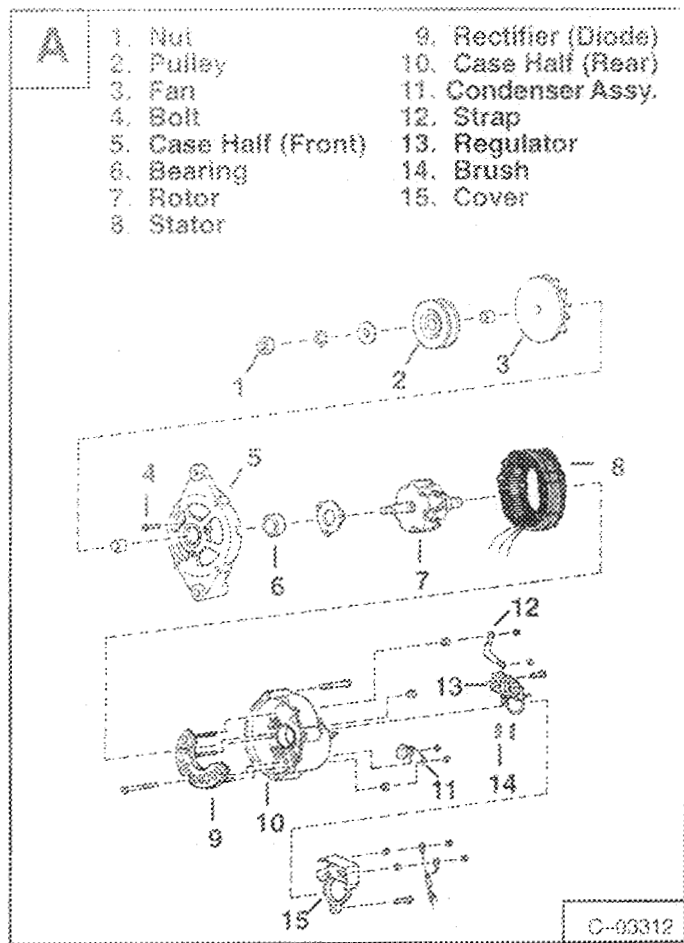

Stator Continuity Test

Use an ohmmeter to test the stator.

Touch the probes to two of the bare stator wires [B].

Move one of the probes to the third wire.

The readings should be the same.

If there is no continuity, replace the stator.

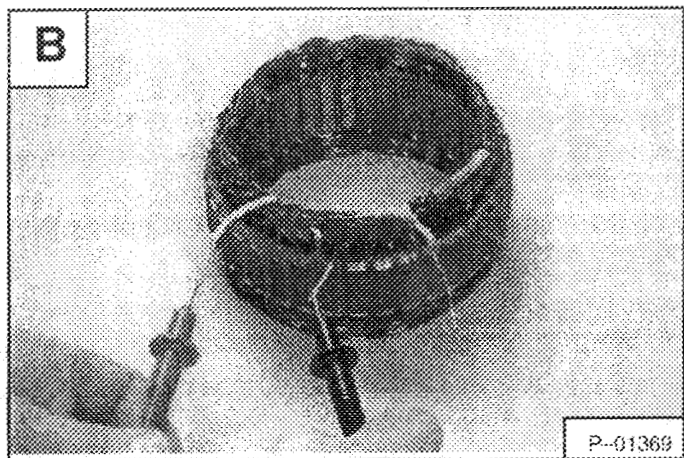

Stator Ground Test

Touch one probe to a bare stator lead and the other probe to the bare metal surface of the stator [C].

There should be no continuity.

Replace the stator if there is continuity.

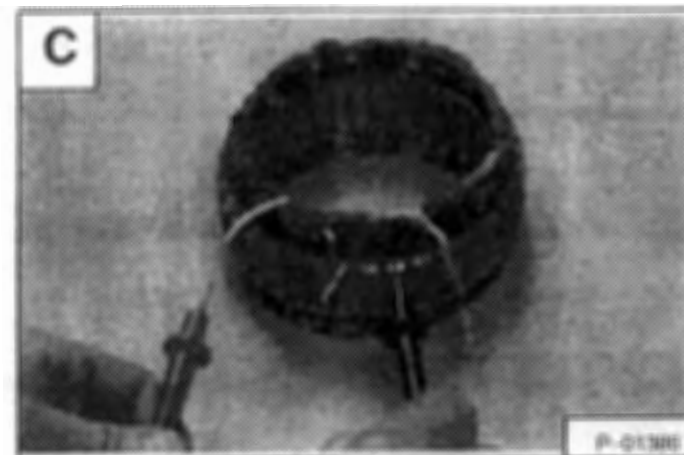

ALTERNATOR (Cont'd)

Rotor Continuity Test

Touch the probes to the slip rings [A].

The ohmmeter should read between 3.065–33.85 ohms.

If there is no continuity replace the rotor.

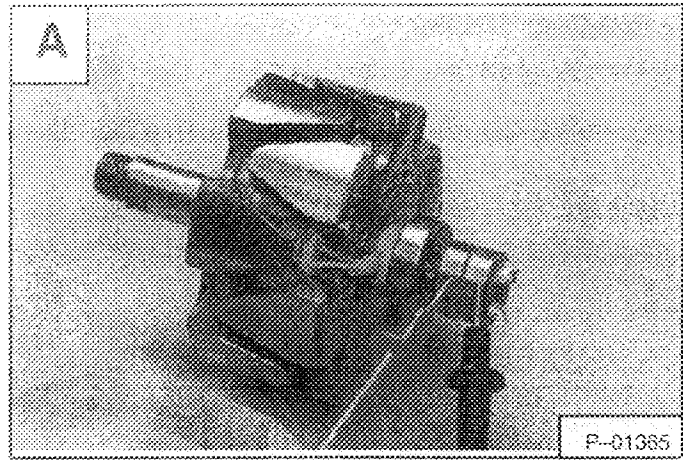

Rotor Ground Test

Touch one probe to one of the slip rings and the other probe to the rotor shaft [B].

There should be no continuity.

Replace the rotor if there is continuity.

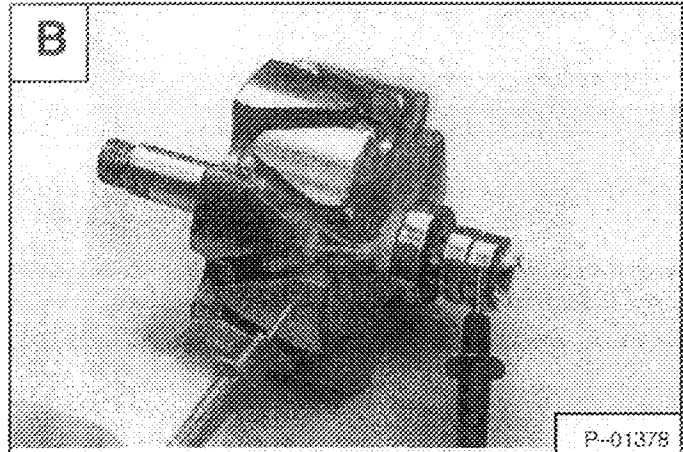

Rectifier Continuity (Diode) Test

NOTE: In the diode tests there should be continuity in one direction only. If the diode being tested shows no continuity or continuity in both directions, replace the rectifier assembly.

Touch the probes to the terminals (Item 1) [C] of each diode and read the meter.

Reverse the probes to check the diode in the other direction.

There should be continuity in one direction only.

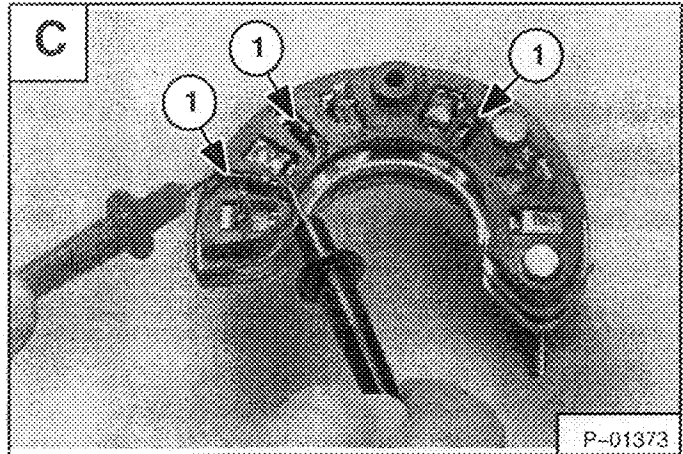

Touch one probe to the diode (Item 1) [D] and the other probe to the connected heatsink and read the meter.

Reverse the probes to check the diode in the other direction.

There should be continuity in one direction only.

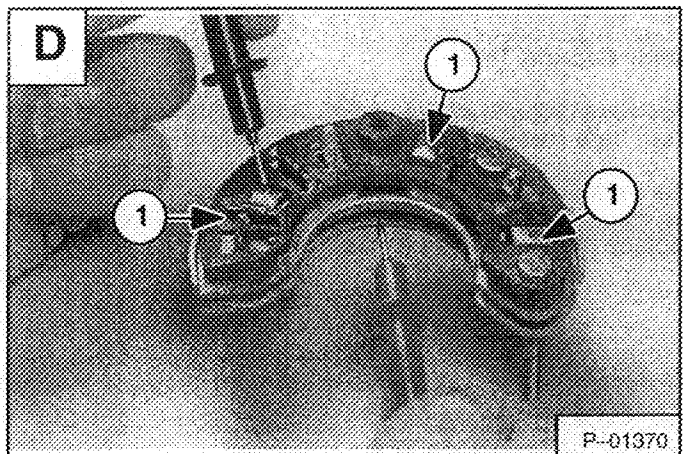

STARTER (DELCO REMY)

Checking The Starter

The key switch must be in the OFF position.

The battery must be at full charge.

The cable connections on the battery must be clean and tight.

Connect a jumper wire between S terminal and BAT terminal [A].

If the starter turns but does not turn the engine, the starter drive has a defect.

Connect a jumper wire between the M terminal and the BAT terminal [B].

If the starter turns, the defect is in the solenoid.

If the starter does not turn, the starter is defective.

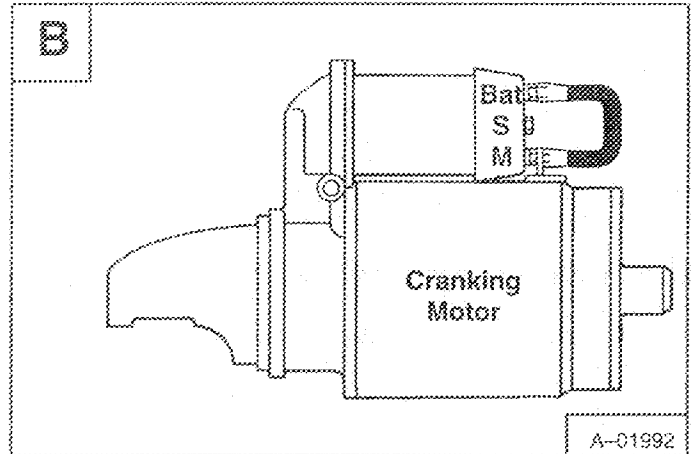
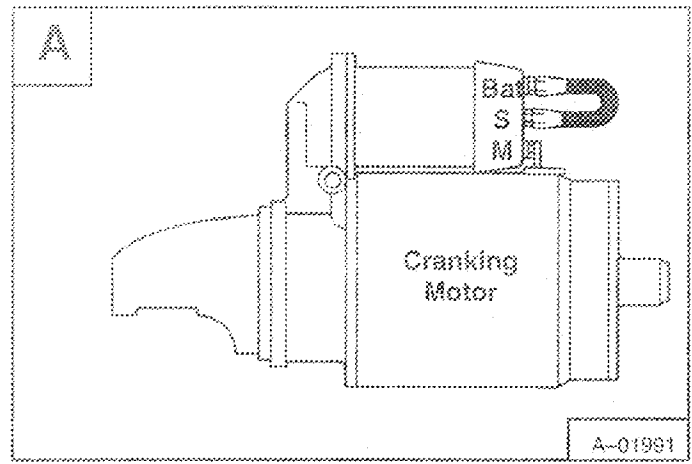

Parts Identification

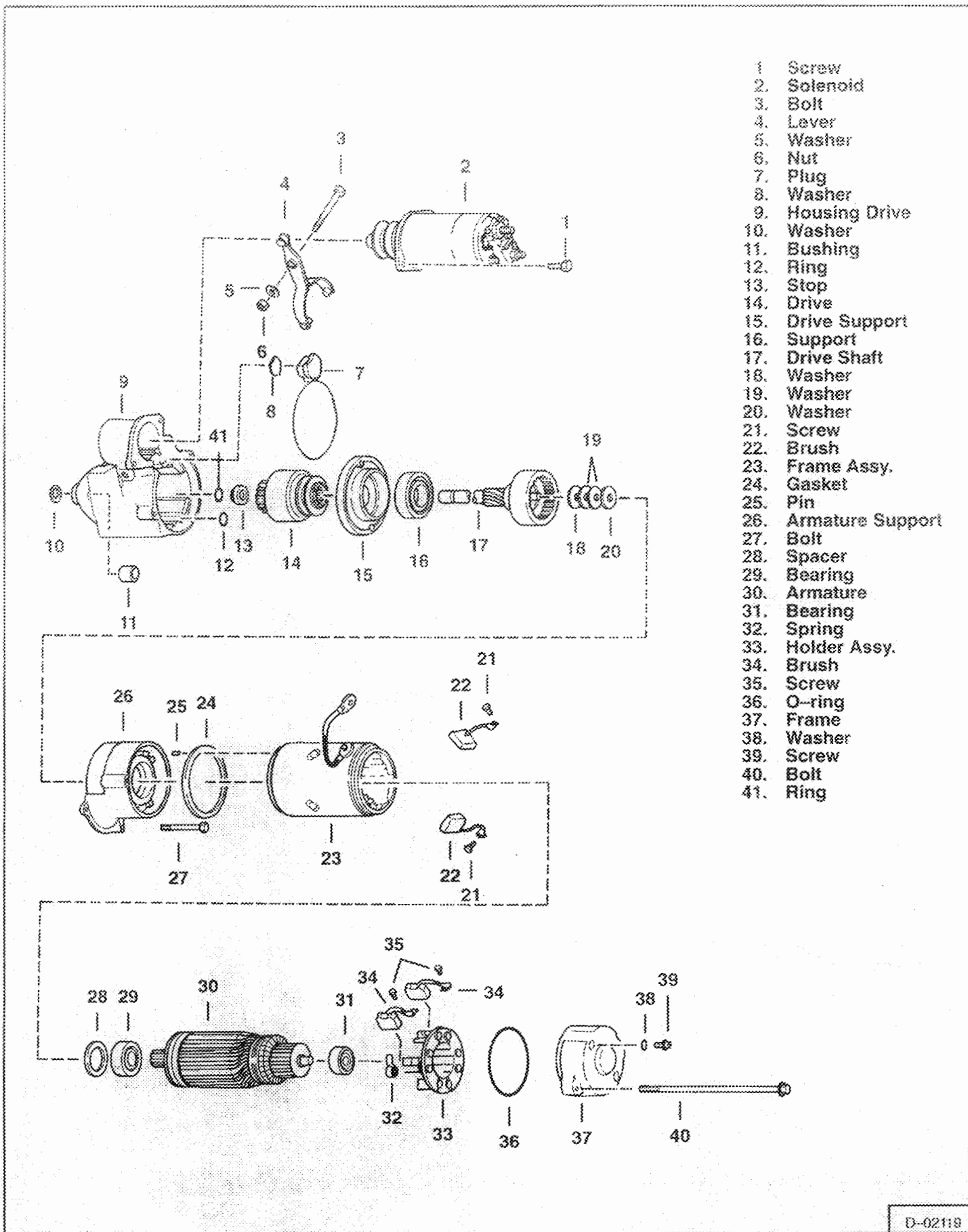

- 1 Screw
- 2 Solenoid
- 3 Bolt
- 4 Lever
- 5 Washer
- 6 Nut
- 7 Plug
- 8 Washer
- 9 Housing Drive
- 10 Washer
- 11 Bushing
- 12 Ring
- 13 Stop
- 14 Drive
- 15 Drive Support
- 16 Support
- 17 Drive Shaft
- 18 Washer
- 19 Washer
- 20 Washer
- 21 Screw
- 22 Brush
- 23 Frame Assy.
- 24 Gasket
- 25 Pin
- 26 Armature Support
- 27 Bolt
- 28 Spacer
- 29 Bearing
- 30 Armature
- 31 Bearing
- 32 Spring
- 33 Holder Assy.
- 34 Brush
- 35 Screw
- 36 O-ring
- 37 Frame
- 38 Washer
- 39 Screw
- 40 Bolt
- 41 Ring

D-02119

Page 137 - 00000000/75-000 - 07/10/2007 10:26:25 - PL:0001 by Ken Cook (k... ed:00000000/75-000)

STARTER (DELCO REMY) (Cont'd)

Disassembly And Assembly

Remove the starter thru-bolts [A].

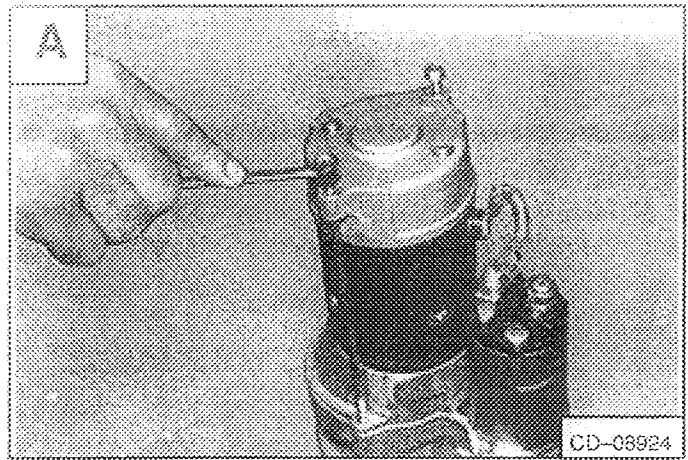

Remove the screws for the brush holders [B].

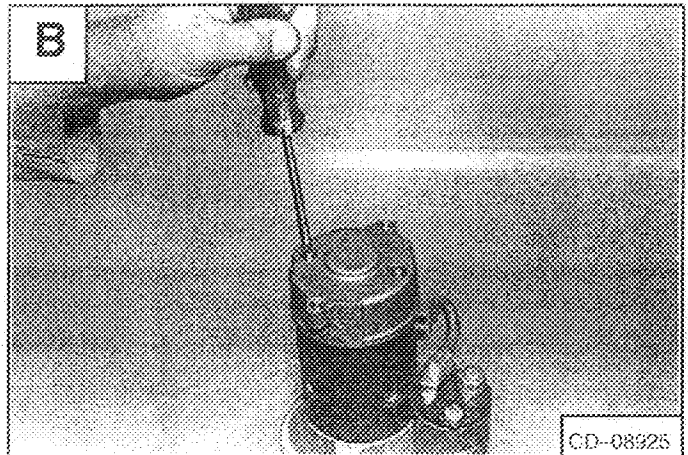

Remove the starter end cap [C].

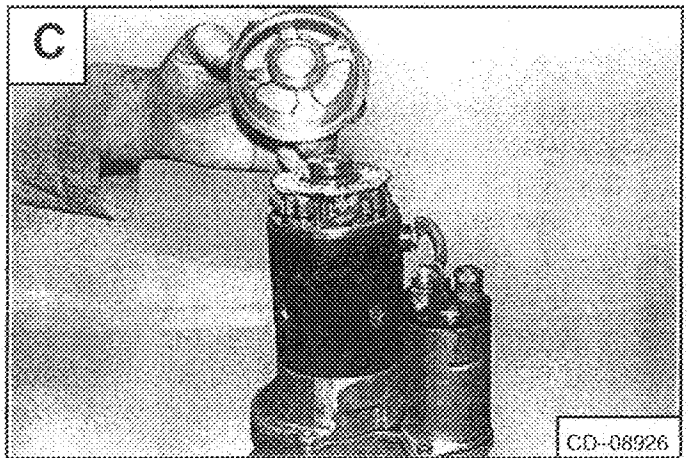

Remove the starter housing/armature assembly from the reduction gear drive [D].

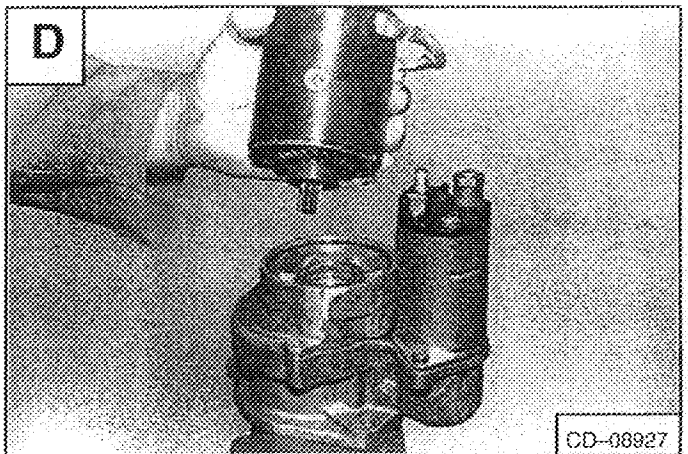

STARTER (DELCO REMY) (Cont'd)

Disassembly And Assembly (Cont'd)

Remove the armature and brushes from the starter housing [A].

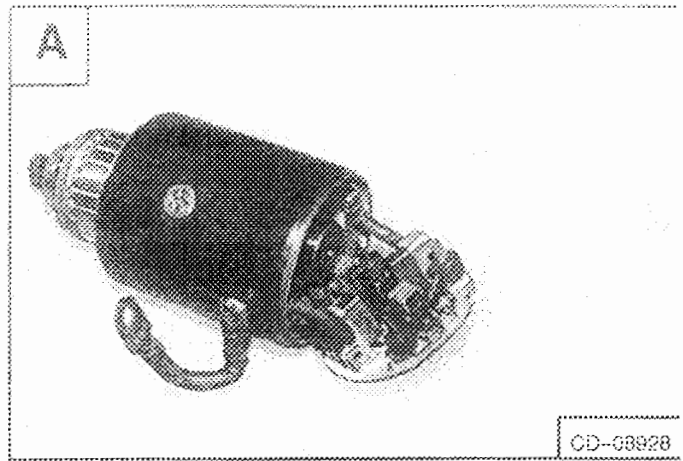

Remove the bolts from the reduction gear housing [B].

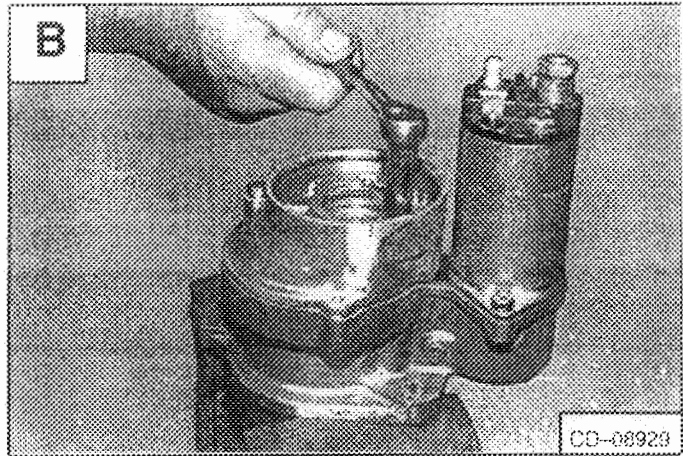

Remove the reduction gear housing [C].

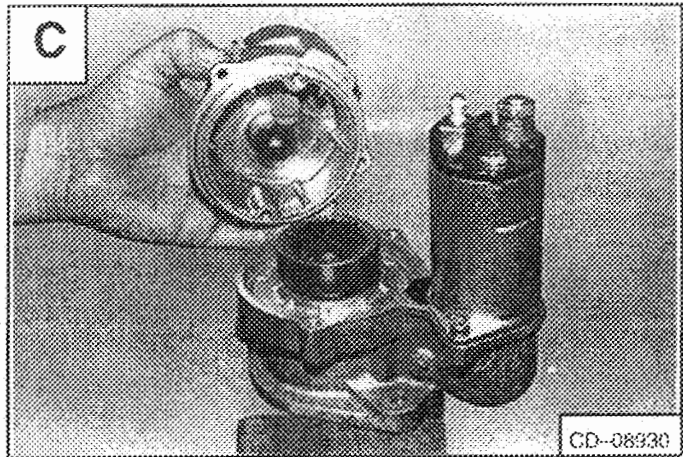

STARTER (DELCO REMY) (Cont'd)

Cleaning And Inspection

Use a brush and air pressure to clean the drive, field coils, armature and starter housing.

NOTE: DO NOT use solvent to clean the drive assembly. The solvent will remove the lubricant and the drive will slip.

Check the following items:

Armature

- Broken or burned insulation
- Loose connections at commutator
- Open or grounded circuits [A] & [B]
- Worn shaft or bearings
- Rough commutator

Brush Holders

- Broken springs
- Broken insulation
- Spring tension

Field Coils

- Broken or burned insulation
- Electrical continuity
- Brush connections

Drive Gears

- Worn teeth
- Tooth engagement

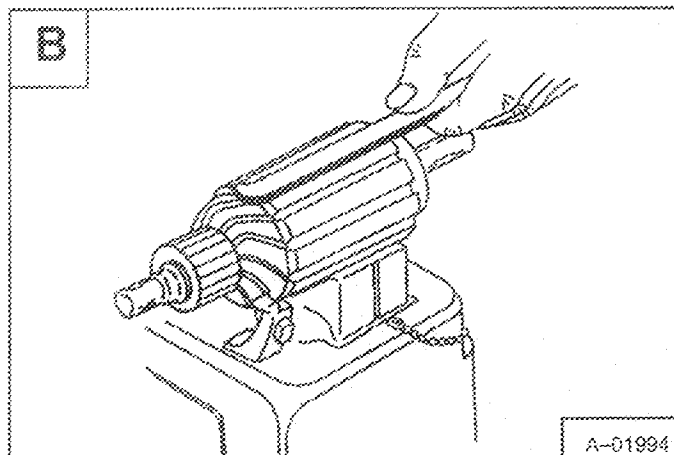
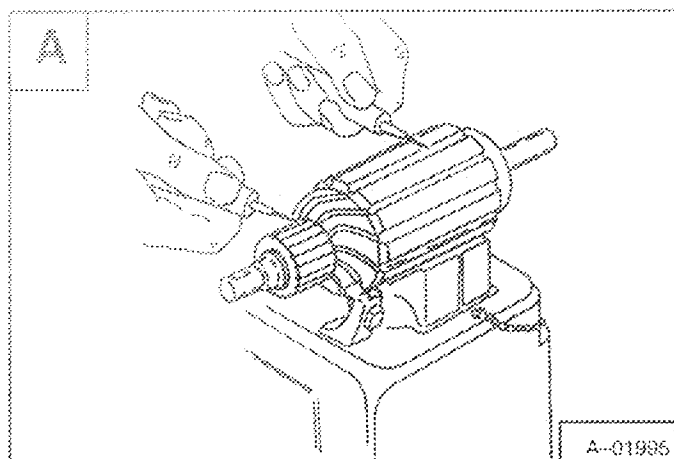

STARTER (DENSO)

Removal And Installation

Stop the engine and open the rear door.

Remove the negative (-) and positive (+) cables from the battery.

Remove the starter mounting bolt (Item 1) [C] and disconnect the ground wires from the starter.

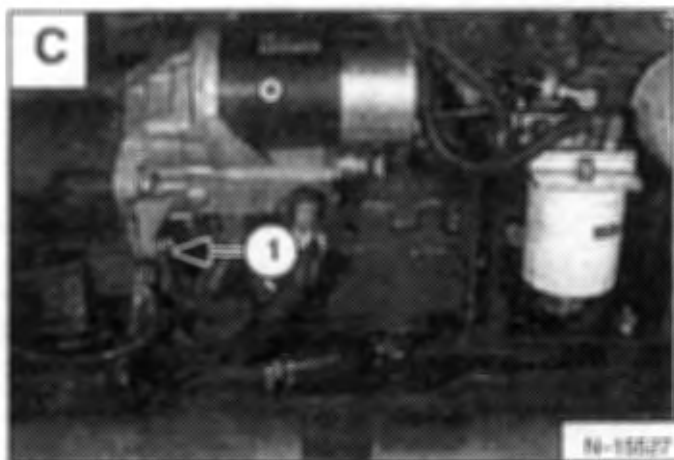

Disconnect the engine harness power wires and positive (+) battery cable starter solenoid terminal (Item 1) [D].

Disconnect the white wire (Item 2) [D] from the S terminal on the starter solenoid.

Remove the mounting bolts (Item 3) [D] from the starter.

Remove the starter from the engine.

Installation: Tighten the three mounting bolts to 25–28 ft.-lbs. (34–38 Nm) torque.

Reverse the removal procedure to install the starter.

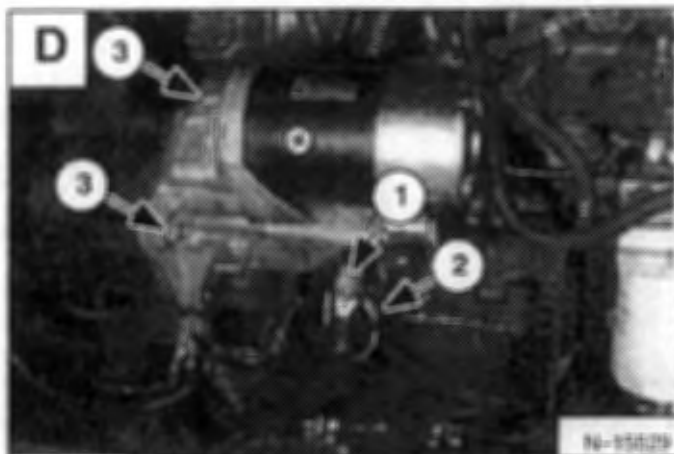

STARTER (DENSO) (Cont'd)

Disassembly

Remove the cable (Item 1) [A] from the magnetic switch.

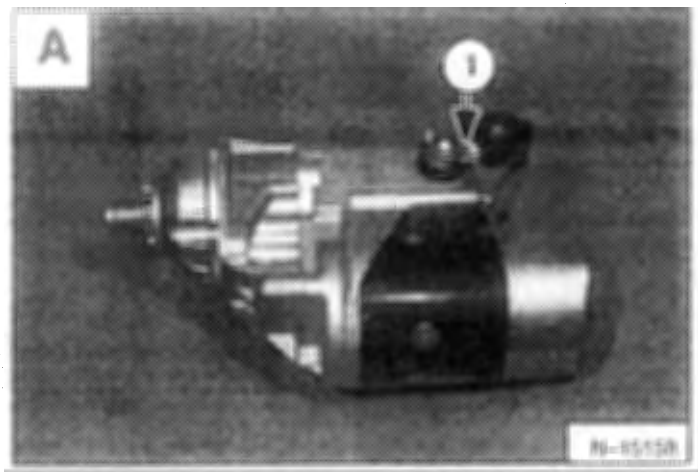

Remove the bolts (Item 1) [B].

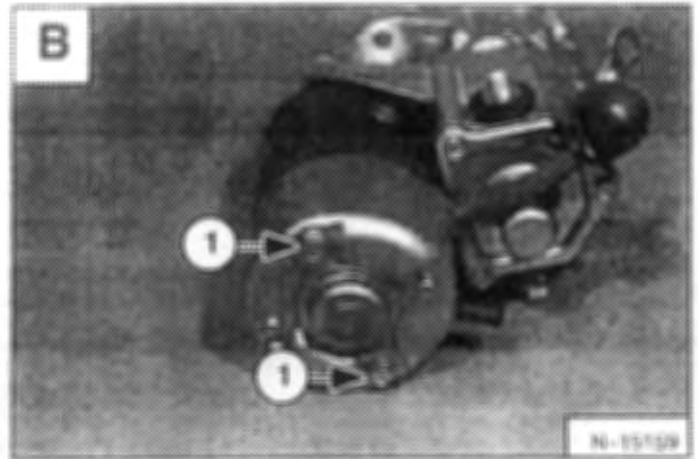

Remove the frame (Item 1) [C] from the magnetic switch.

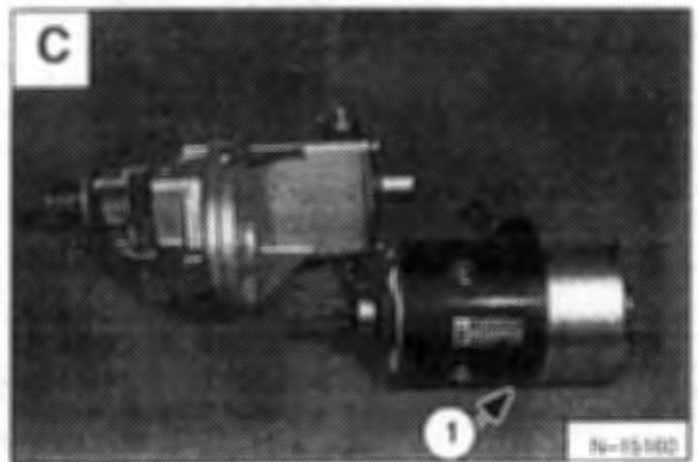

Remove the screws (Item 1) [D] from the brush cover (Item 2) [D].

Remove the cover (Item 2) [D].

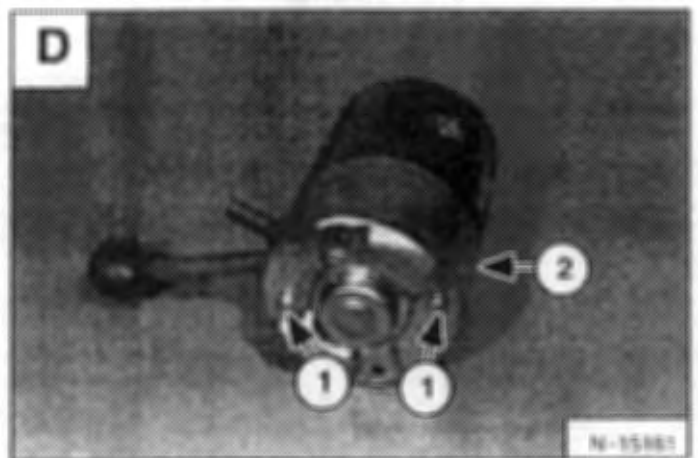

STARTER (DENSO) (Cont'd)

Disassembly (Cont'd)

Using a needle nose pliers, pull the brush springs (Item 1) [A] back and remove the brushes (Item 2) [A].

NOTE: The brushes are non-replaceable. If the brushes are worn order a new brush holder (for the negative brushes) and yolk (for the positive brushes).

Remove the brush holder (Item 3) [A] from the end of the armature.

Remove the armature (Item 1) [B] from the frame.

Remove the bearings (Item 2) [B] from both ends of the armature.

Remove the bolts (Item 1) [C] from the starter housing.

Remove the starter housing (Item 1) [D] from the magnetic switch.

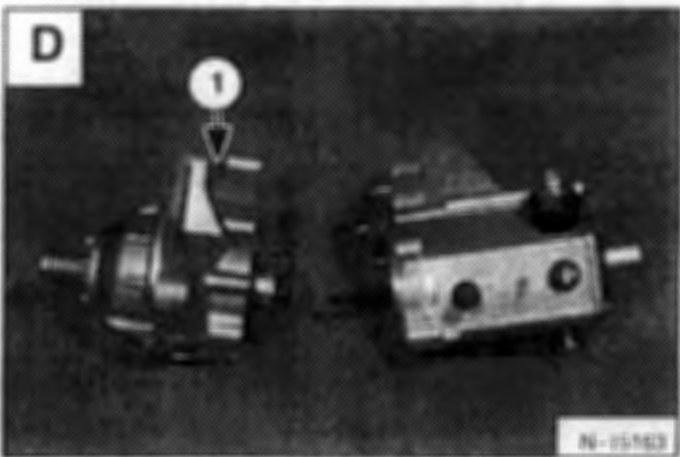
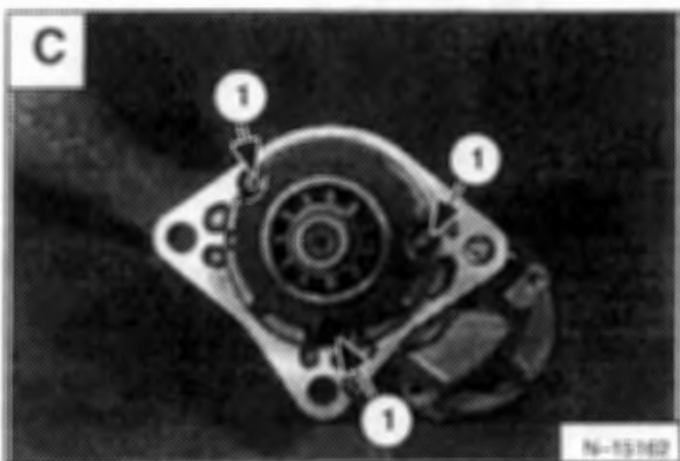
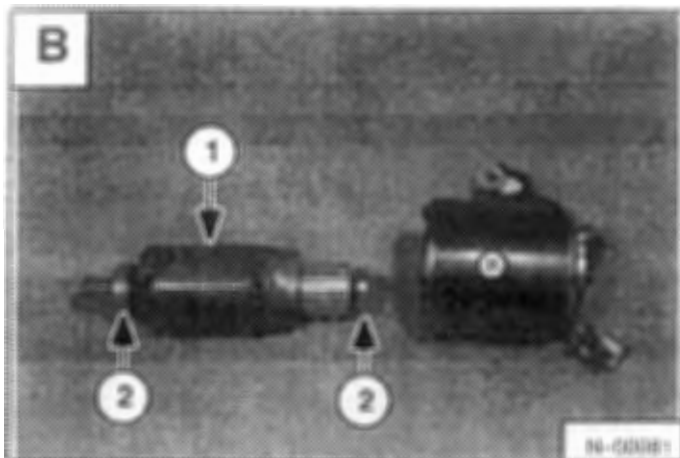
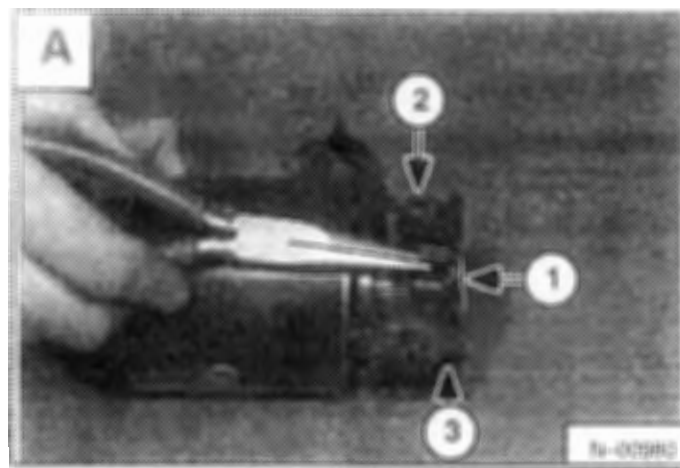

Page 24 - 08082121/080801 - 05/17/2007 10:40:26 - Printed by Ken York Co - eSprint.com (P. 18.1 / 23/2007)

STARTER (DENSO) (Cont'd)

Disassembly (Cont'd)

Remove the ball (Item 1) [A] from the pinion shaft.

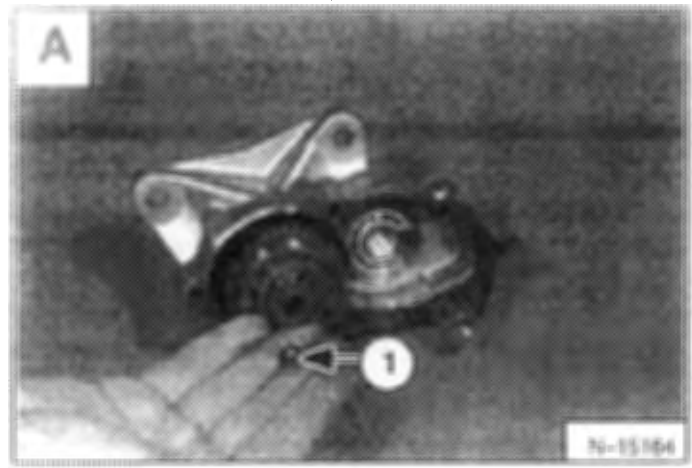

Tap the starter pinion/clutch assembly (Item 1) [B] out of the starter housing.

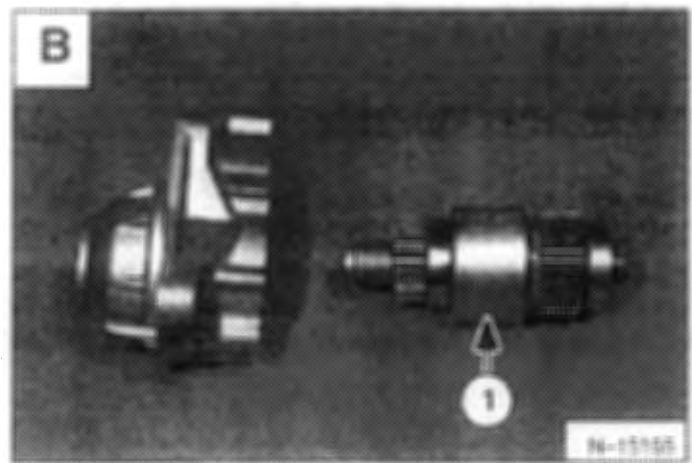

Remove the O-ring (Item 1) [C].

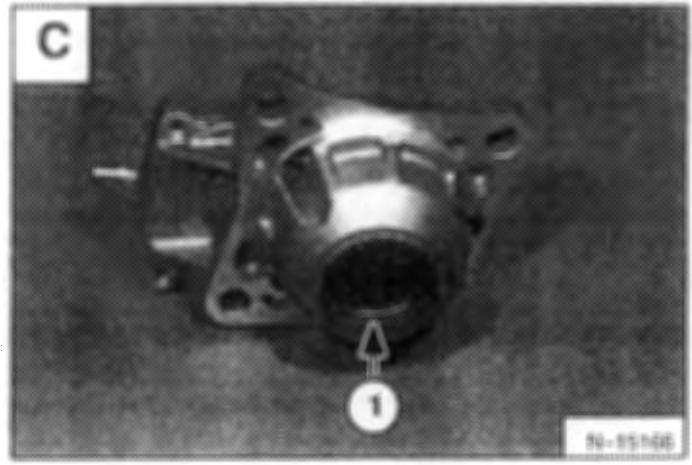

Press down on the pinion (Item 1) [D] and retainer (Item 2) [D].

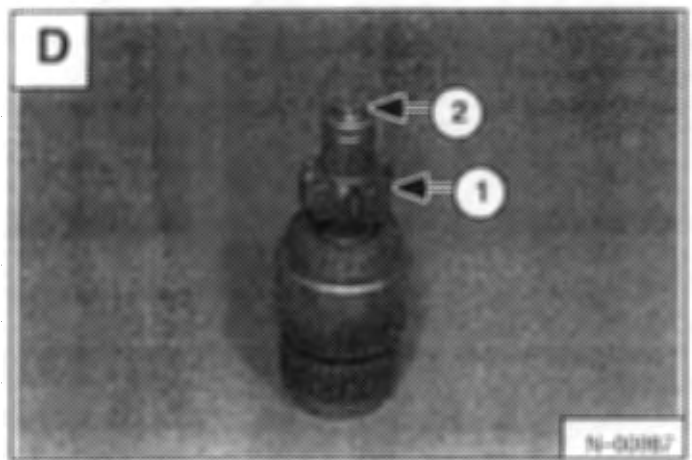

STARTER (DENSO) (Cont'd)

Disassembly (Cont'd)

Remove the snap ring (Item 1) [A].

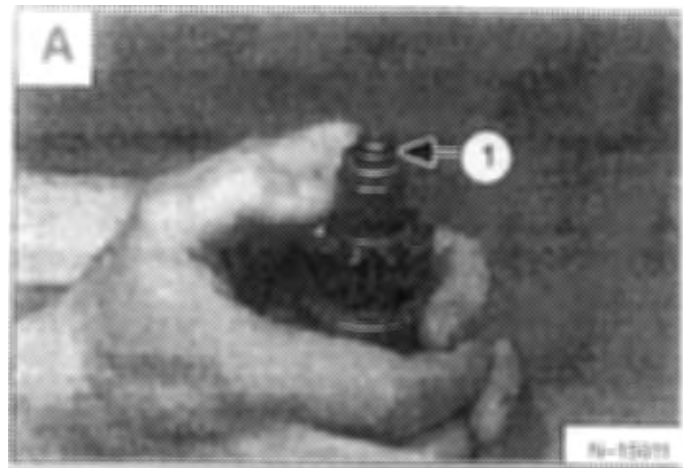

Remove the retainer (Item 1) [B] and pinion (Item 2) [B].

Remove the spring seat (Item 3) [B] and spring (Item 4) [B].

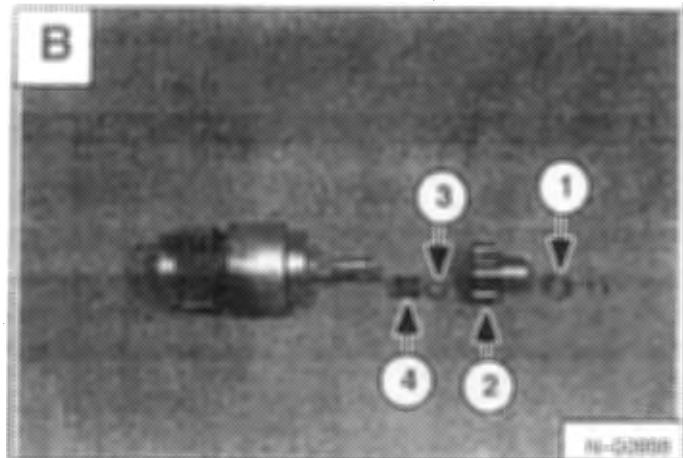

Remove the pinion shaft (Item 1) [C] and spring (Item 2) [C] from the over running clutch (Item 3) [C].

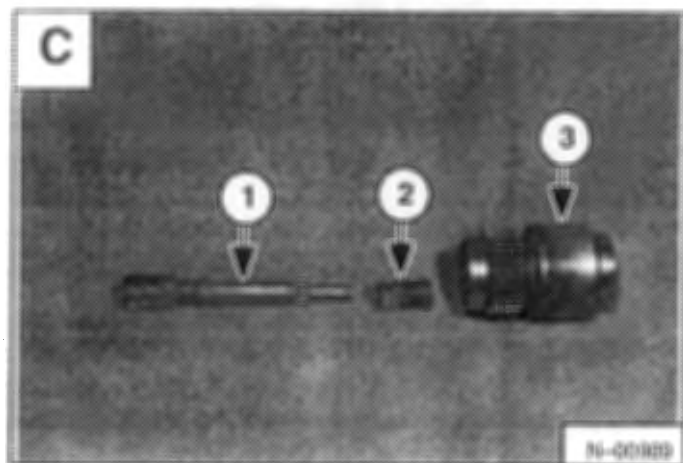

Remove the spring (Item 1) [D] from the magnetic switch housing.

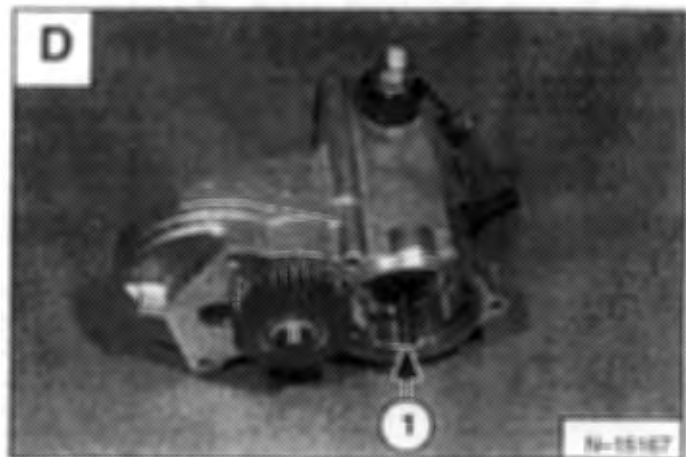

Copyright © 2007 Deere & Company. All rights reserved. Printed in the USA. 10-2007-001

STARTER (DENSO) (Cont'd)

Disassembly (Cont'd)

Remove the idler gear (Item 1) [A], retainer (Item 2) [A] and rollers (Item 3) [A] from the magnetic switch housing.

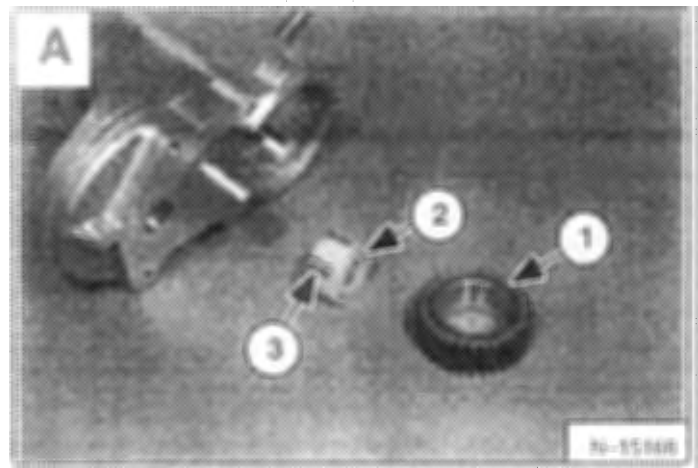

Remove the washer (Item 1) [B] from the idler gear shaft.

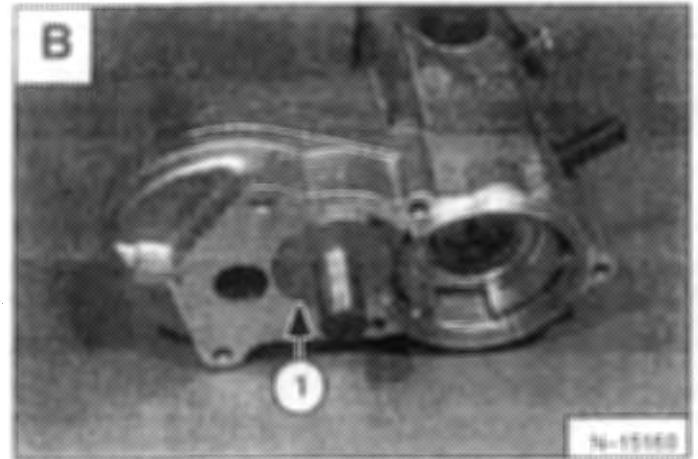

Remove the screws (Item 1) [C] from the magnetic switch cover.

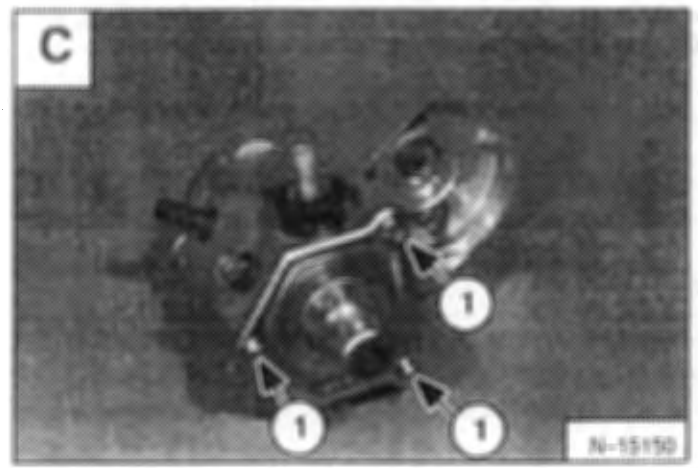

Remove the cover (Item 1) [D], gasket (Item 2) [D] and switch (Item 3) [D].

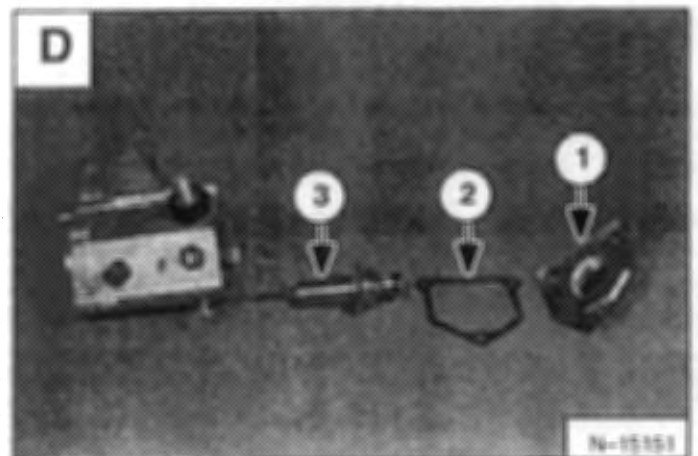

STARTER (DENSO) (Cont'd)

Inspection And Repair

Inspect the brush cover for discoloration, indicating the starter has been overheated.

Inspect the pinion teeth for wear and damage.

Armature Short-Circuit Test: Use a growler tester, put the armature on the growler and hold a hack saw blade against the armature core while slowly rotating the armature [A]. A short circuited armature causes the blade to vibrate and be attracted to the core. An armature which is short-circuited must be replaced.

Armature Winding Ground Test: Use a circuit tester, touch one probe to a commutator segment and the other probe to the armature core [B]. There should be no continuity. If there is continuity, the armature is grounded and must be replaced.

Armature Winding Continuity Test: Use a circuit tester, touch the probes to two commutator segments [C]. There should be continuity at any point. If there is no continuity, the winding is open-circuited, replace the armature.

Commutator Run-Out Test: Check the commutator run-out as shown in [D].

Service Limit - 0.020 inch (0,4 mm)

If the commutator exceeds the service limit, repair as needed.

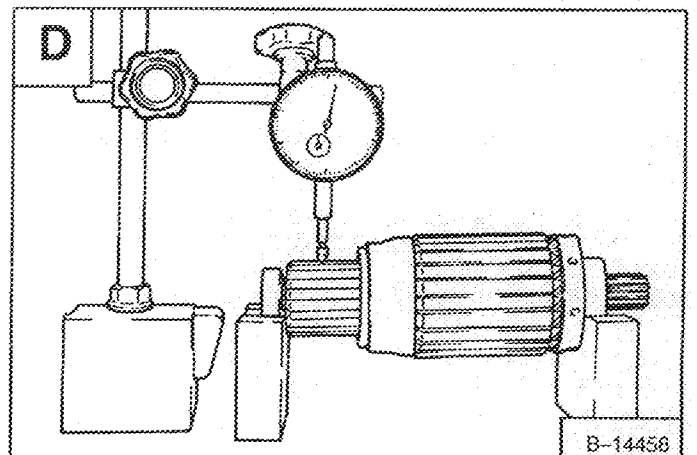
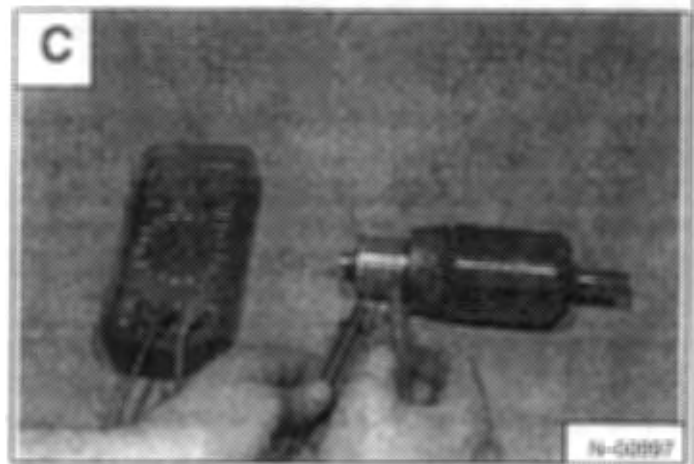
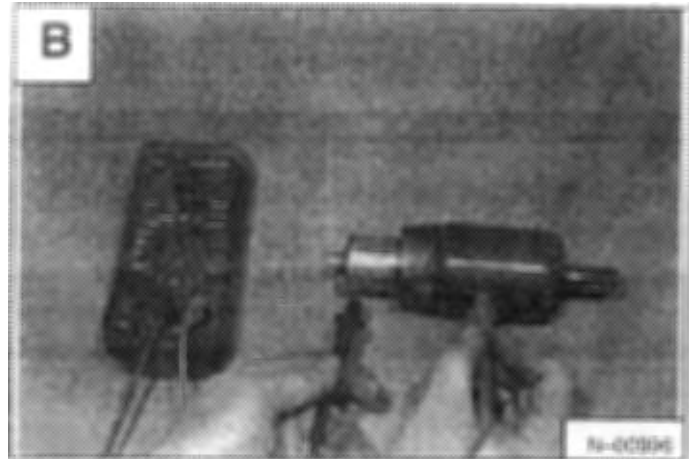
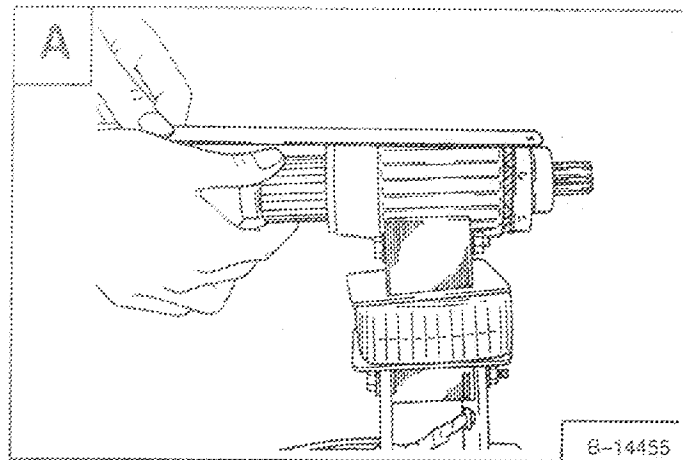

Copyright © 2007, Caterpillar Inc. All rights reserved. Printed in the U.S.A. 1-800-4-A-CATERPILLAR

STARTER (DENSO) (Cont'd)

Inspection And Repair (Cont'd)

Measure the segment mica depth (Item 1) [A].

Service Limit -- 0.008 inch (0.2 mm)

If it is worn, replace the armature.

Check the commutator surface for burned spots which usually indicates an open-circuit, and correct it using #400 sand paper.

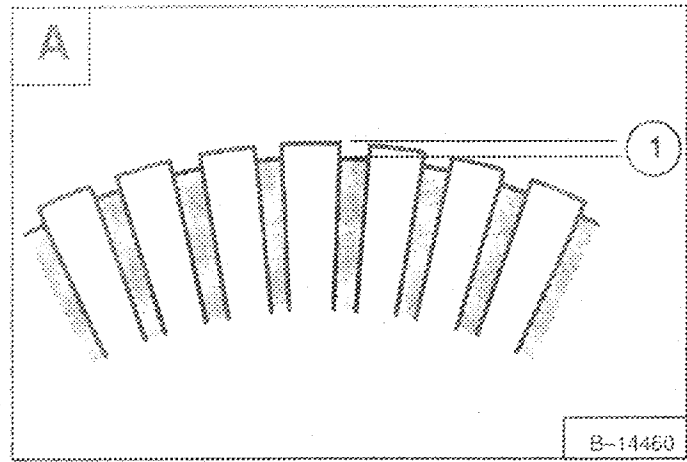

Check the field windings for wear and damage.

Check all the connections for clean and tight solder joints.

Field Winding Ground Test: Use a circuit tester, touch one probe to the field winding end of the brush and the other probe to the surface of the frame [B]. There should be no continuity. If there is continuity, the field windings are grounded.

Replace the frame.

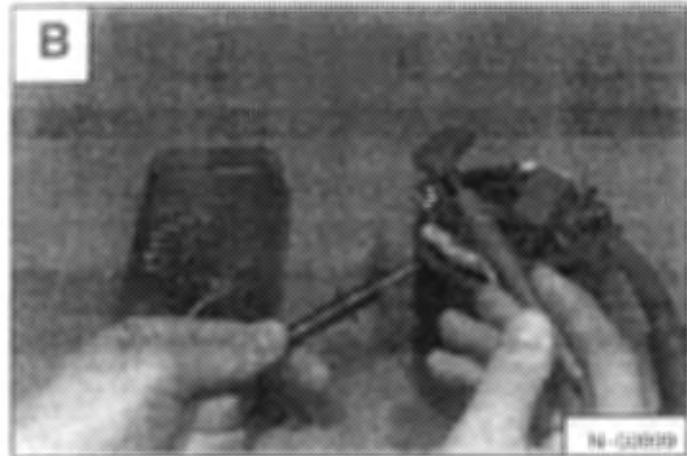

Field Windings Continuity Test: Use a circuit tester, touch one probe to the wire and the other probe to the brush [C]. There should be continuity. If there is no continuity, the field windings are open-circuited.

Replace the frame.



Inspect the brushes for wear and damage.

Replace the brush holder and yoke if the brushes need replacement.

Check brush spring, for damage or rust. Replace as needed.

Brush Holder Insulation Test: Use a circuit tester, touch one probe to the positive brush holder plate and the other probe to the holder plate [D]. There should be no continuity. If there is continuity, replace or repair.



STARTER (DENSO) (Cont'd)

Inspection And Repair (Cont'd)

NOTE: Assemble the over running clutch, pinion shaft, springs, and pinion for this test.

Inspect the pinion. It must rotate freely in the direction of the starter rotation and locked in the opposite rotation.

Pull the pinion out (to the engaged position) [A] and allow it to snap back to the retracted position. The pinion must fully return to the retracted position.

The following tests should be done without the armature assembly. Install the magnetic switch in the switch housing.

NOTE: Each test should be performed a short time (3 to 5 seconds) to prevent the magnetic switch winding from burning. Each test should be performed with 12 volts.

Pull-In Test: Connect the wires as shown in [B]. When connecting Terminal C and M.T. are closed, the pinion should engage.

Hold-In Test: With the same conditions as in the pull-in test, open the connecting Terminal C [C]. The pinion should remain in the engaged position.

Return Test: With the same conditions as in the hold-in test, open the connecting Terminal 50 [D]. The pinion should return immediately.

M.T. . . . Main Terminal to which the main cable from the battery is connected.

C C-Terminal to which the wire from the field windings is connected.

50 50-Terminal to which the wire from the starting switch or stator relay is connected.

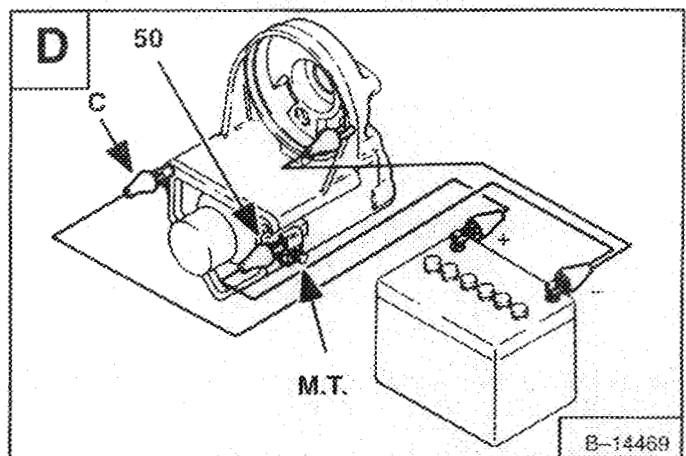
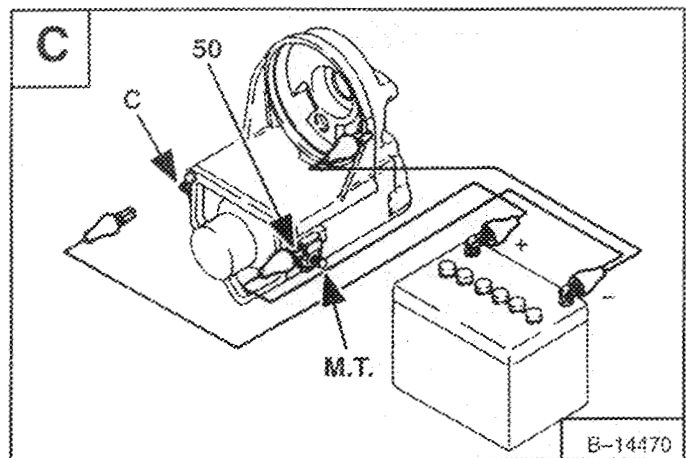
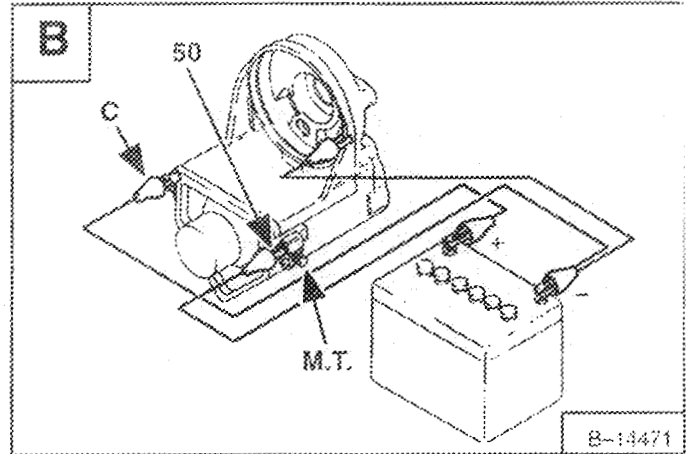
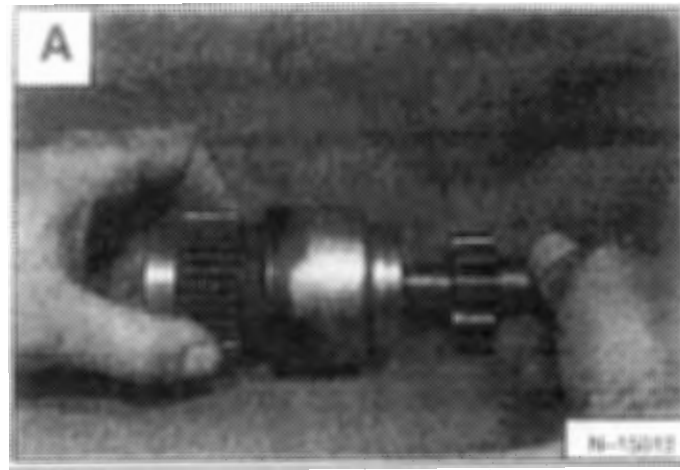

STARTER (DENSO) (Cont'd)

No Load Test

The following test should be done after reassembling the starter:

Clamp the starter in a vise. Using a 12 volt battery and ammeter, connect the positive wire of the battery, and the ammeter to the 50 terminal [A]. Connect the negative wire to the starter body. Using a jumper wire, connect the 50 terminal to the main terminal.

The starter should show smooth and steady rotation immediately after the pinion is engaged, it should draw less than the specified current.

Service Limit - 220 Amp. Maximum Draw

Assembly

Clean all parts and apply high temperature grease to the armature bearing, return spring, steel ball, over running clutch, and idler gear rollers.

Install the switch plunger (item 1) [B], gasket (item 2) [B] and cover (item 3) [B] on the switch housing.

Install the screws (item 1) [C].

Install the washer (item 1) [D] on the idler gear shaft.

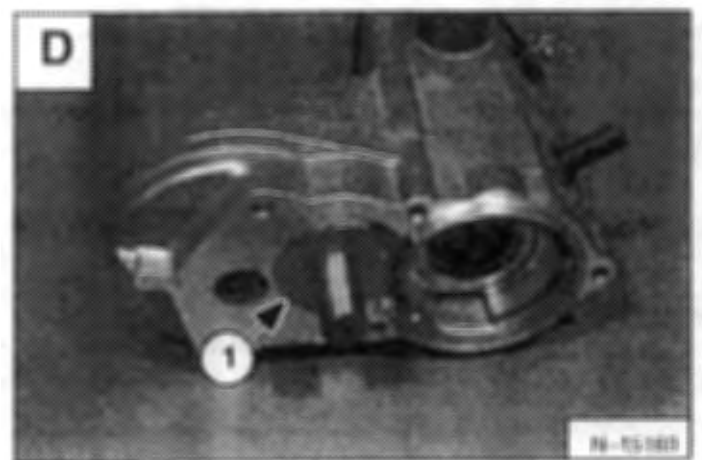
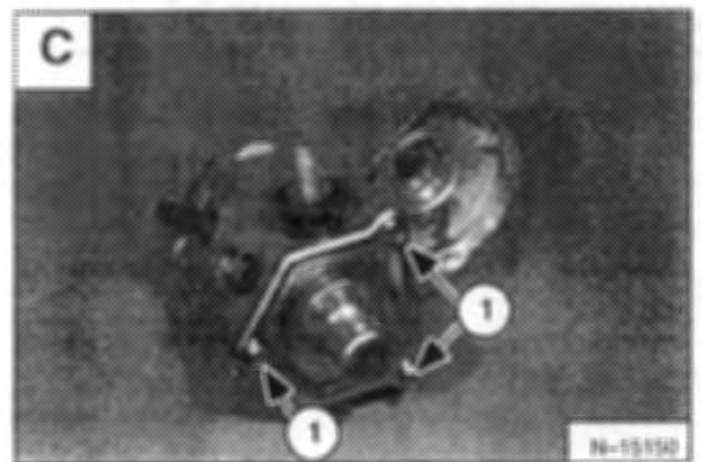
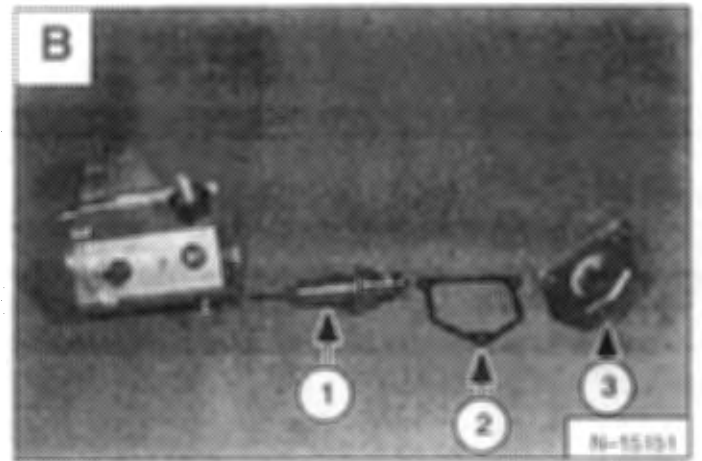
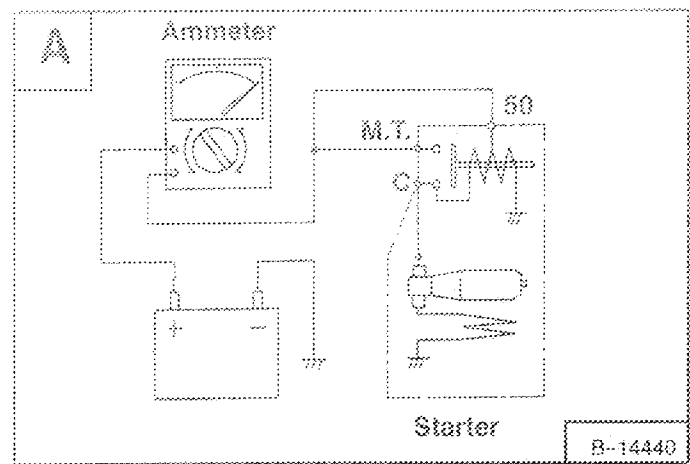

STARTER (DENSO) (Cont'd)

Assembly (Cont'd)

Install the rollers (Item 1) [A] in the retainer (Item 2) [A].

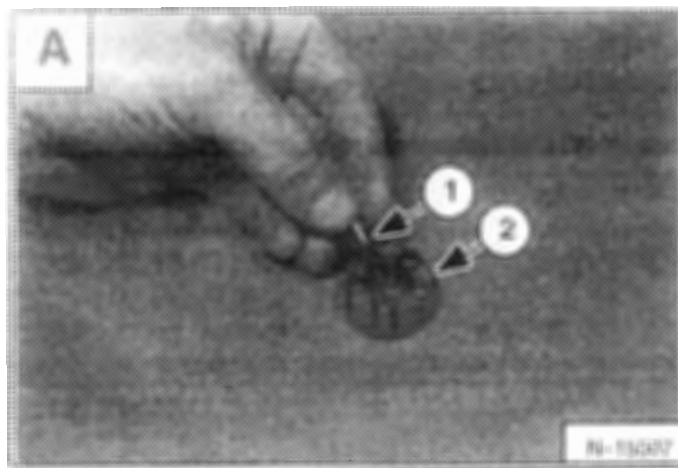

Install the roller/retainer assembly (Item 1) [B] on the idler gear shaft.



Install the idler gear (Item 1) [C] over the retainer.



Install the spring (Item 1) [D] in the magnetic switch housing.

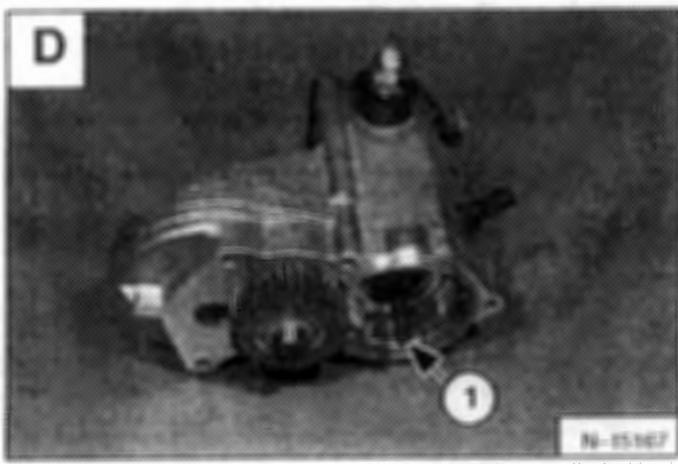

STARTER (DENSO) (Cont'd)

Assembly (Cont'd)

Install the spring (Item 1) [A] over the pinion shaft (Item 2) [A]. Install the pinion shaft (Item 2) [A] in the over running clutch (Item 3) [A].

Stand the clutch assembly on end.

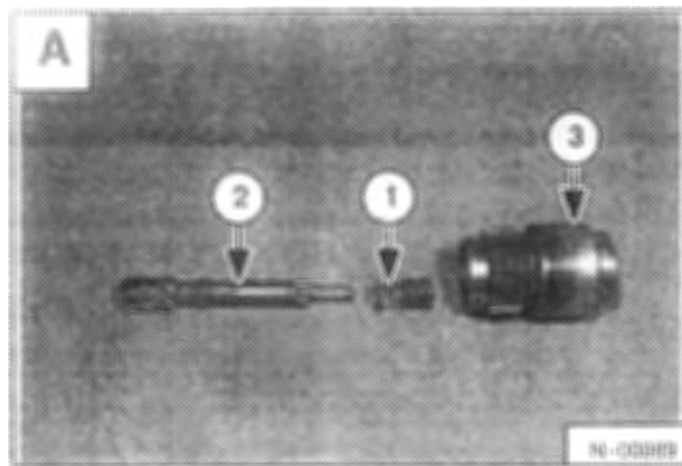

Install the spring (Item 1) [B] and spring seat (Item 2) [B] on the pinion shaft.

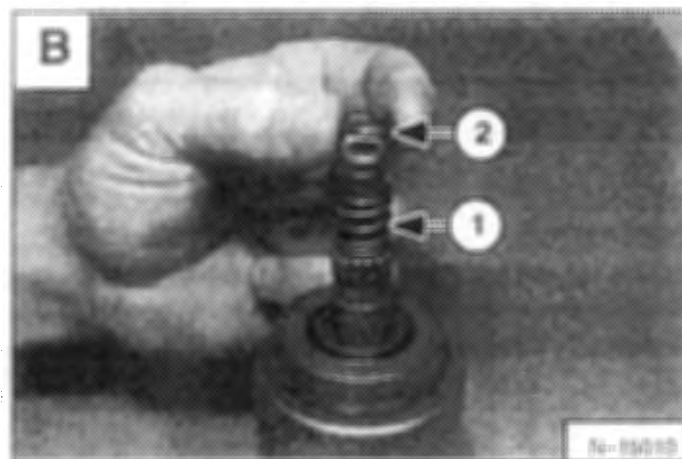

Install the pinion (Item 1) [C] and retainer (Item 2) [C] on the pinion shaft.

Press down on the pinion (Item 1) [C] and install the snap ring (Item 3) [C] on the pinion shaft.

Pull the retainer (Item 2) [C] over the snap ring (Item 3) [C].

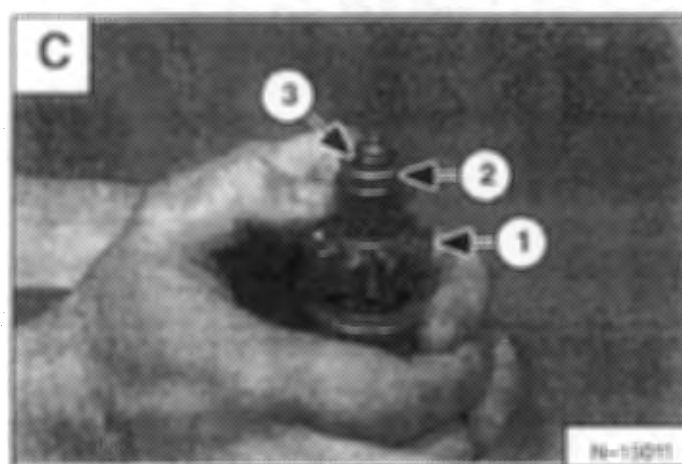

Install the O-ring (Item 1) [D] in the starter housing.

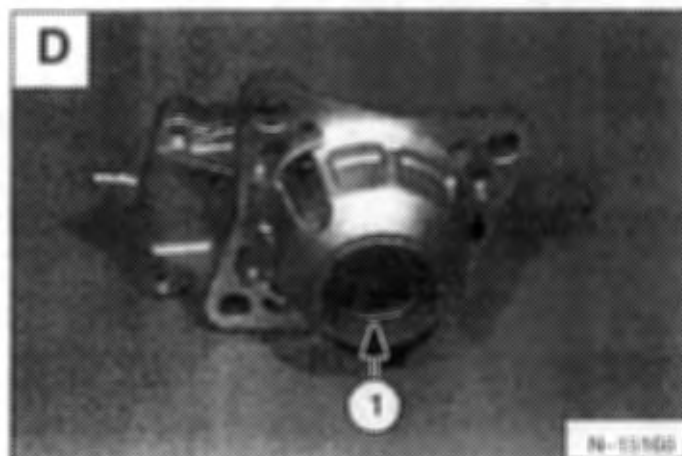

STARTER (DENSO) (Cont'd)

Assembly (Cont'd)

Install the bearings (Item 1) [A] & [B] on both ends of the armature.

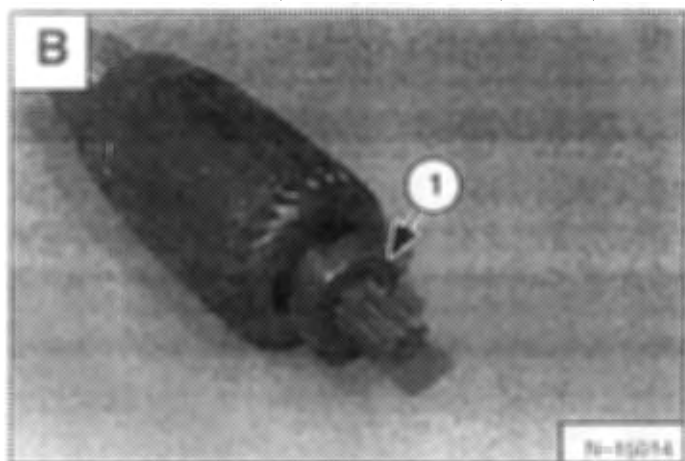
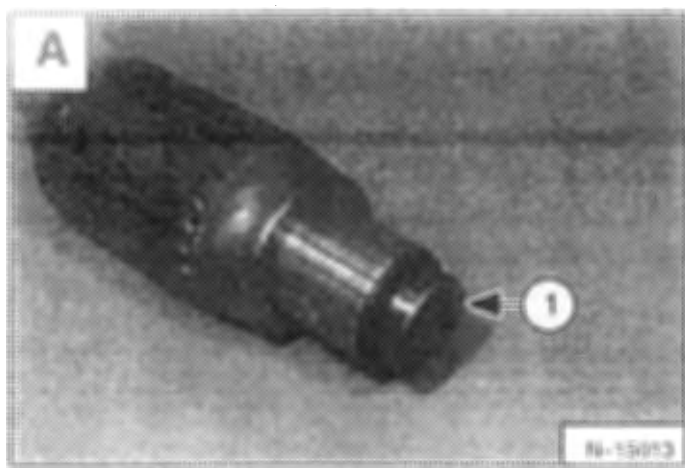

Install the armature (Item 1) [C] in the frame.

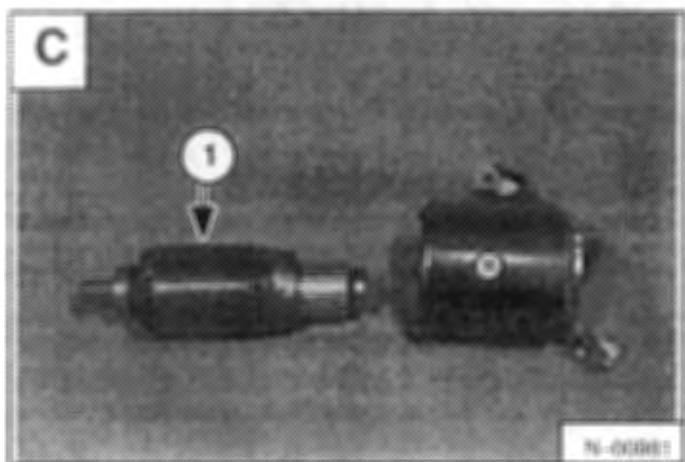

STARTER (DENSO) (Cont'd)

Assembly (Cont'd)

Install the frame/armature assembly (Item 1) [A] on the housing.

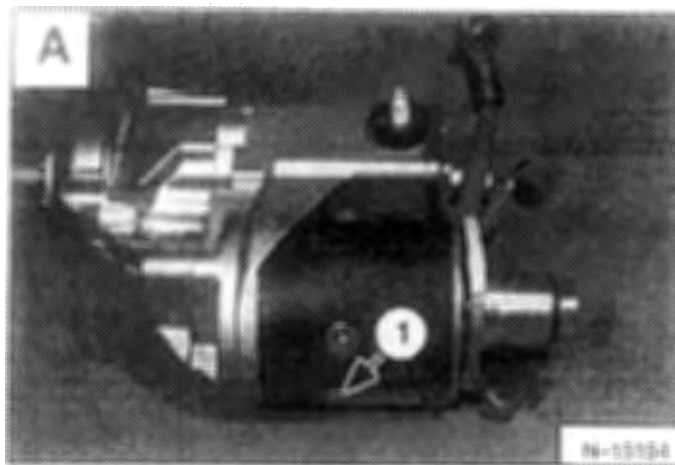

NOTE: Make sure the notch (Item 1) [B] in the frame matches up with the notch (Item 2) [B] in the housing.

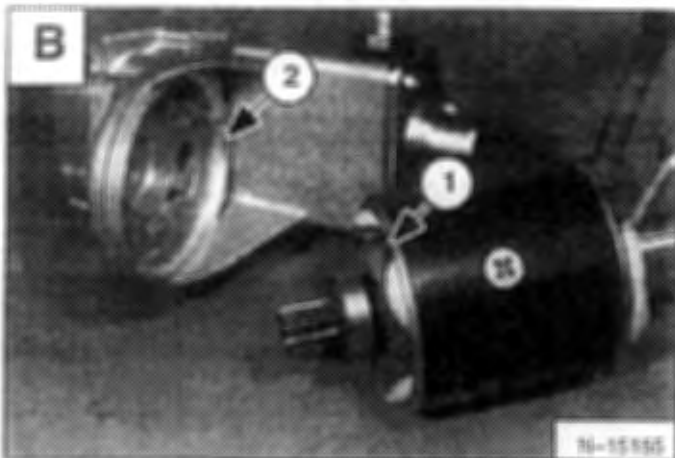

Install the brush holder (Item 1) [C] on the end of the armature.

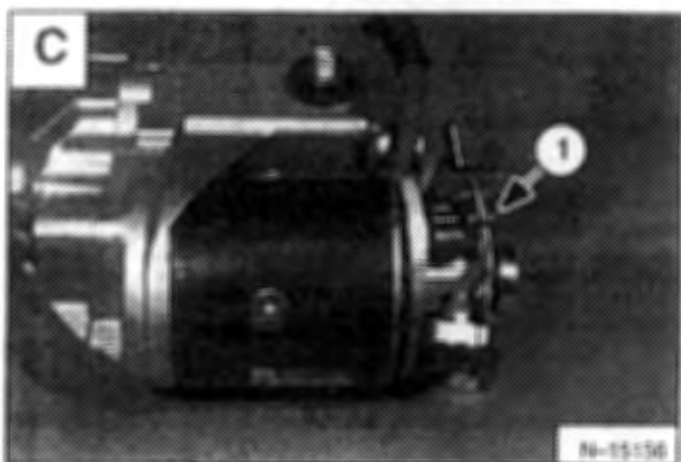

Using the needle nose pliers, pull the brush springs (Item 1) [D] back and install the brushes (Item 2) [D].

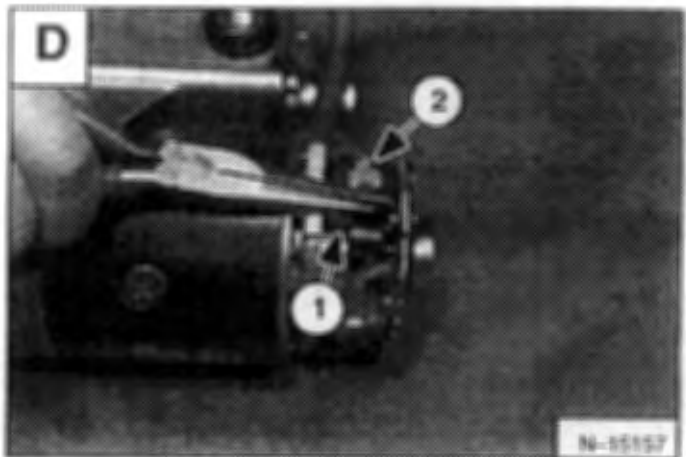

STARTER (DENSO) (Cont'd)

Assembly (Cont'd)

Install the brush cover (Item 1) [A] and screws (Item 2) [A]. Tighten the screws to 29-40 in.-lbs. (3.0-5.0 Nm) torque.

Install the thru bolts (Item 3) [A]. Tighten the bolts to 60-104 in.-lbs. (7-12 Nm) torque.

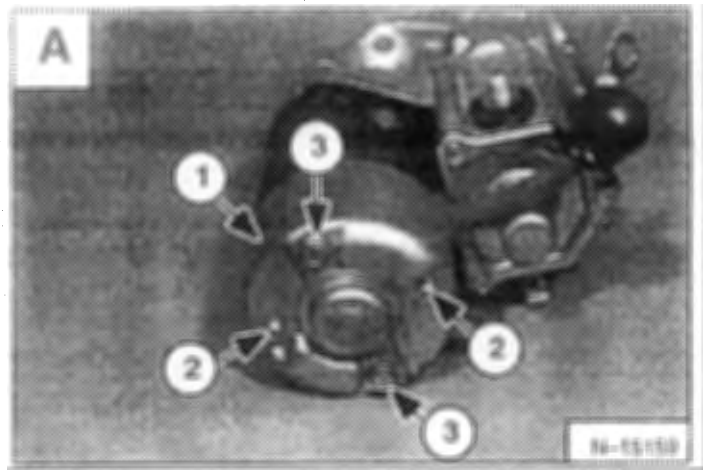

Install the cable (Item 1) [B] on the magnetic switch. Tighten the nut to 18-26 ft.-lbs. (24-35 Nm) torque.

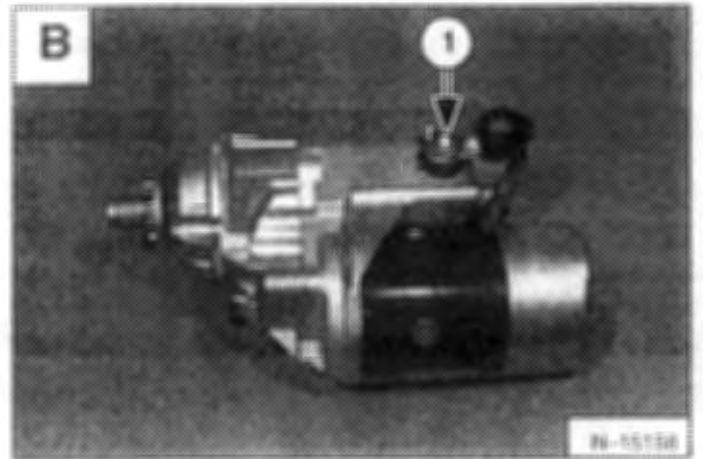

FRONT LIGHTS

Removal And Installation

The front lights are mounted in the upper corners of the operator cab [A].

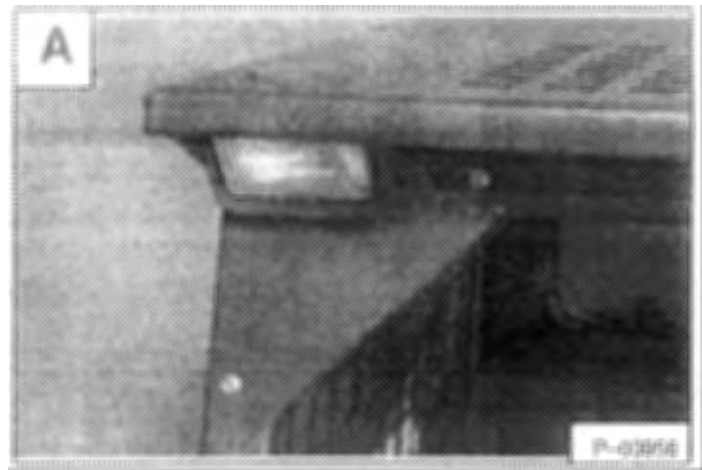

Pry the rubber light mount free from the operator cab [B].



Pull the light down and remove the three mounting bolts (Item 1) [C] from the instrument panel.

Disconnect the front light connector from the instrument panel. Remove the front light from the operator cab.

Reverse the removal procedure to install the front light.

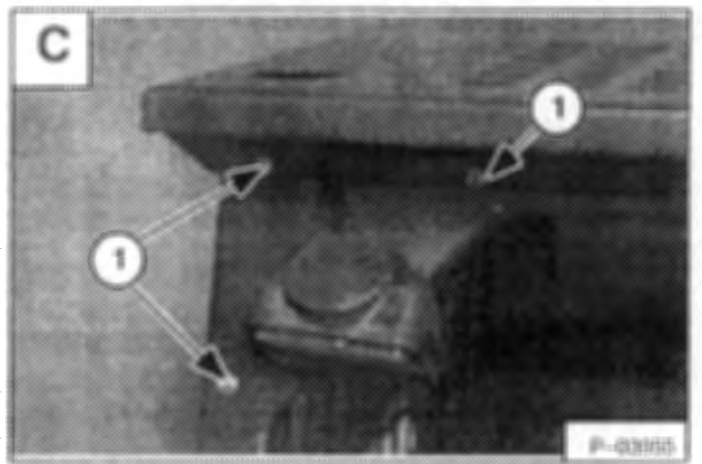

RELAY SWITCHES

Location

The loader engine harness has relay switches located beneath the engine air cleaner [A] and [B]

There are five switches (item 1) [A] on the BOSS® equipped loader.

The switches are for the starter, switch power, glow plug, brake and shutdown.

There are four switches (item 1) [B] on the standard equipped loader.

The switches are for the starter, switch power, glow plug and brake.

Remove the bolt (item 2) [A] & [B] from the mounting tab on the switch and replace if the switch malfunctions.

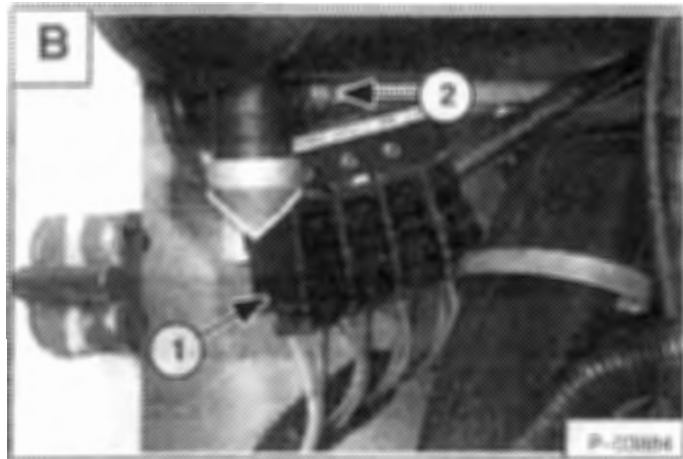
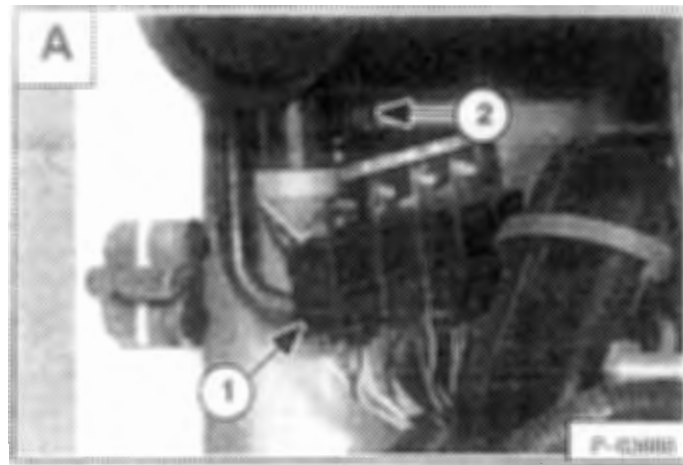

page 475 • 30000385/7664401 • 09/10/1007 01:29:27 • 001001007 01:29:27 • 001001007 01:29:27 • 001001007 01:29:27 • 001001007 01:29:27 • 001001007 01:29:27



bobcat®