

DATI TECNICI • TECHNICAL DATA • TECHNISCHE MERKMALE

Portata nominale (max) <i>Nominal flow (max)</i> Nominaler Durchfluß (max)	45 (55) l/min 11.9 (14.5) gpm
Pressione massima <i>Maximum pressure</i> Maximaler Betriebsdruck	300 (4351) bar (psi)
Contropressione massima allo scarico <i>Maximum tank pressure</i> Maximaler Gegendruck Tankleitung	50 (730) bar (psi)
Massima trafila interna <i>Maximum internal leakage</i> Maximale interne Leckage	8 cc/min (21 cSt - 100 bar)
Temperatura d'utilizzo <i>Temperature range</i> Betriebstemperatur	-20°C +80°C NBR seals -20°C +130°C HNBR seals
Viscosità olio <i>Oil viscosity</i> Ölviskosität	Da 10 cSt a 100 cSt <i>From 10 cSt to 100 cSt</i> Von 10 cSt nach 100 cSt
Fluido <i>Fluid</i> Öl	Olio a base minerale <i>Mineral based oil</i> Mineral Öl

FILETTATURA • THREAD • GEWINDE

CODICE MODEL BEZEICHNUNG	TIPO TYPE GEWINDE	COPPIA DI SERRAGGIO Nm TORQUE Nm ANZUGSMOMENT Nm
C	M 18 X 1,5	40
B	1/2 Gas	70
E	3/4" UNF-16	50

DIMENSIONI • SIZE • ABMESSUNGEN

N° DI SEZIONI N° OF SECTIONS ANZAHL ELEMENTE	L mm (inch)	MASSA Kg (lb) WEIGHT Kg (lb) GEWICHT Kg (lb)
DN3	151 (5.94)	7.3 (16.0)
DN4	191 (7.52)	9.4 (20.7)
DN5	231 (9.1)	11.5 (25.3)
DN6	271 (10.67)	13.6 (30.0)

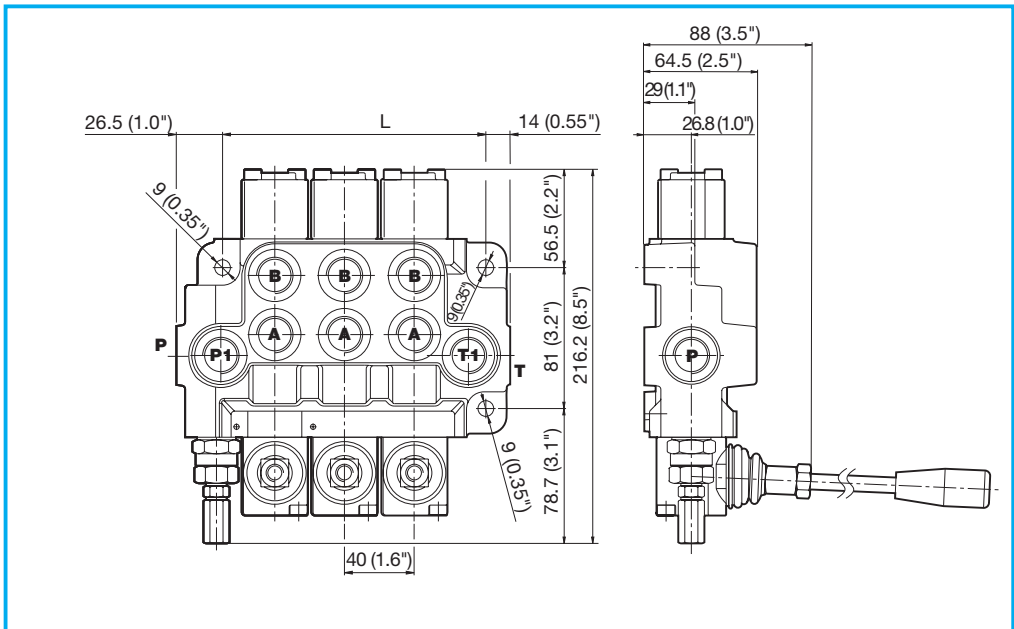
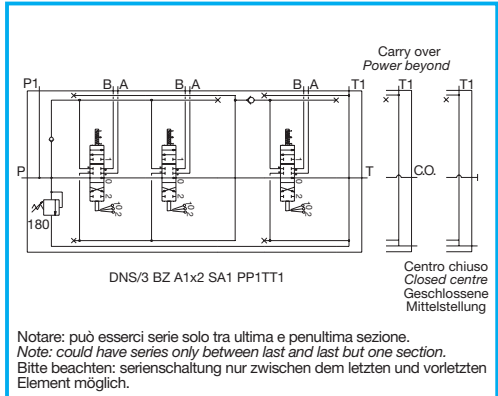



CURVE CARATTERISTICHE
FLOW CURVES
TYPISCHE KURVEN

Le curve caratteristiche in catalogo sono tipiche di prodotti di produzione testati in laboratorio e non sono necessariamente rappresentative di ogni unità.
Performance Characteristics shown in catalog are typical of production products tested in laboratory and are not necessarily representative of any other unit.
Die Werte im Katalog beziehen sich auf Standardware, die auf der Prüfbank getestet wurde und sind nicht repräsentativ für andere Einheiten.

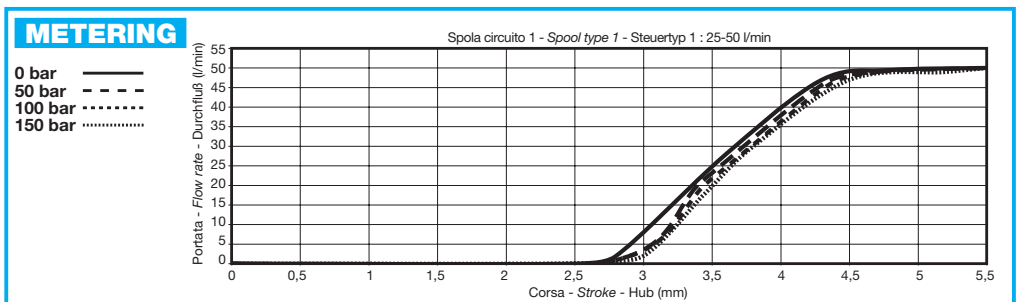
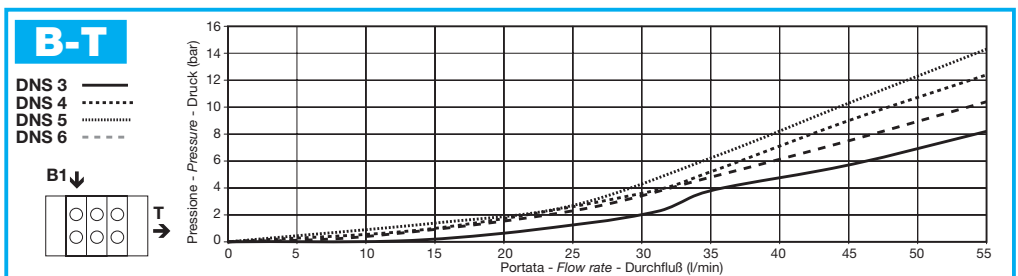
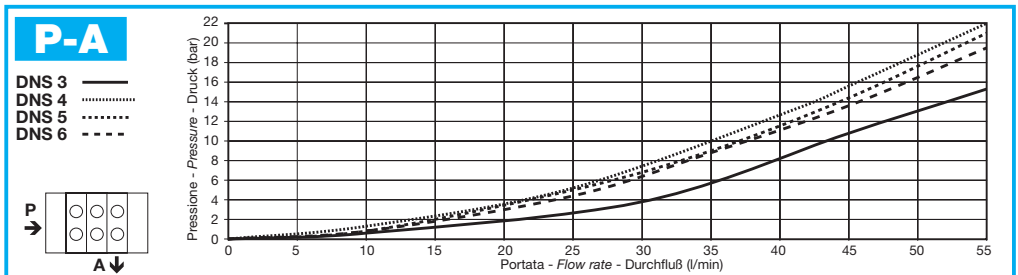
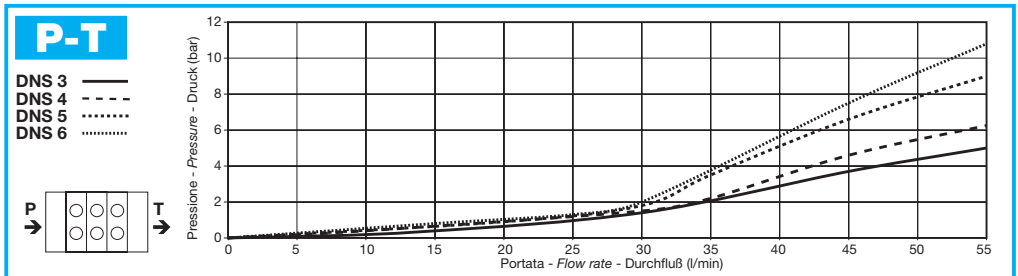

Parametri di prova / Testing parameters / Prüfparameter: 50°C - 21 cSt (spola circuito 1 - spool type 1- steuertyp 1)

CIRCUITI E SCHEMI IDRAULICI
HYDRAULIC CIRCUITS AND SCHEMES
STEUERTYPEN UND HYDRAULISCHE SCHEMATA

POSIZIONATORE • SPOOL CONTROL • SCHIEBERSTELLUNG	
A	<p>Posizione neutra in 0 Neutral position in 0 Neutralstellung in 0</p>
B	<p>Posizione neutra in 0, detent in 1 Neutralstellung in 0, rastend in 1</p>
C	<p>Posizione neutra in 0, detent in 2 Neutral position in 0, detent in 2 Neutralstellung in 0, rastend in 2</p>
D	<p>Detent in 0, 1, 2 Detent in 0, 1, 2 Raststellung in 0, 1 und 2</p>
NT	<p>Posizione neutra in 0, detent in 4 Neutral position in 0, detent in 4 Neutralstellung in 0, rastend in 4</p>
R	<p>Posizione neutra in 2 Neutral position in 2 Neutralstellung in 2</p>
S	<p>Posizione neutra in 1 Neutral position in 1 Neutralstellung in 1</p>

CIRCUITO • SPOOL TYPE • STEUERTYP	POS. 3 POS. 1 POS. 0 POS. 2 POS. 4				
	1		P → B A → T BP →	P → T A → B BP →	P → A B → T BP →
3		P → B A → T BP →	A, B → T P → B BP →	P → A B → T BP →	
4		A → T P, B → A BP →	P → T A → B BP →	P → A B → T BP →	
5		P → B A, T → A BP →	P → T A → B BP →	P, A → B B → T BP →	
70		P → B A → T BP →	P → T A → B BP →	P → A B → T BP →	A, B → T P →

Le configurazioni mostrate sono riferite a prodotti standard, se la vostra applicazione richiede diversamente, prego di contattare il responsabile vendite di zona.
 Products as shown are typical of standard products, if your application needs some deviation in design, please contact our local sales representative.

Die abgebildeten Produkte sind typische Standardwaren. Sollten Sie für Ihre Anwendung Änderungen bezüglich des Aussehens benötigen, wenden Sie sich bitte an Ihren zuständigen Vertreter.

POSIZIONATORE SPOOL CONTROL SCHIEBERSTELLUNG	CIRCUITO • CIRCUIT • CIRCUIT				
	1	3	4	5	70
A	<input checked="" type="checkbox"/>	<input checked="" type="checkbox"/>	<input checked="" type="checkbox"/>	<input checked="" type="checkbox"/>	-
B	<input checked="" type="checkbox"/>	<input checked="" type="checkbox"/>	<input checked="" type="checkbox"/>	<input type="checkbox"/>	-
C	<input checked="" type="checkbox"/>	<input checked="" type="checkbox"/>	<input type="checkbox"/>	<input checked="" type="checkbox"/>	-
D	<input checked="" type="checkbox"/>	<input checked="" type="checkbox"/>	<input checked="" type="checkbox"/>	<input checked="" type="checkbox"/>	-
NT	-	-	-	-	<input checked="" type="checkbox"/>
R	<input checked="" type="checkbox"/>	<input checked="" type="checkbox"/>	<input type="checkbox"/>	<input type="checkbox"/>	-
S	<input checked="" type="checkbox"/>	<input checked="" type="checkbox"/>	<input checked="" type="checkbox"/>	<input type="checkbox"/>	-



**ISTRUZIONI PER L'ORDINAZIONE
ORDERING INSTRUCTIONS
BESTELLANLEITUNG**

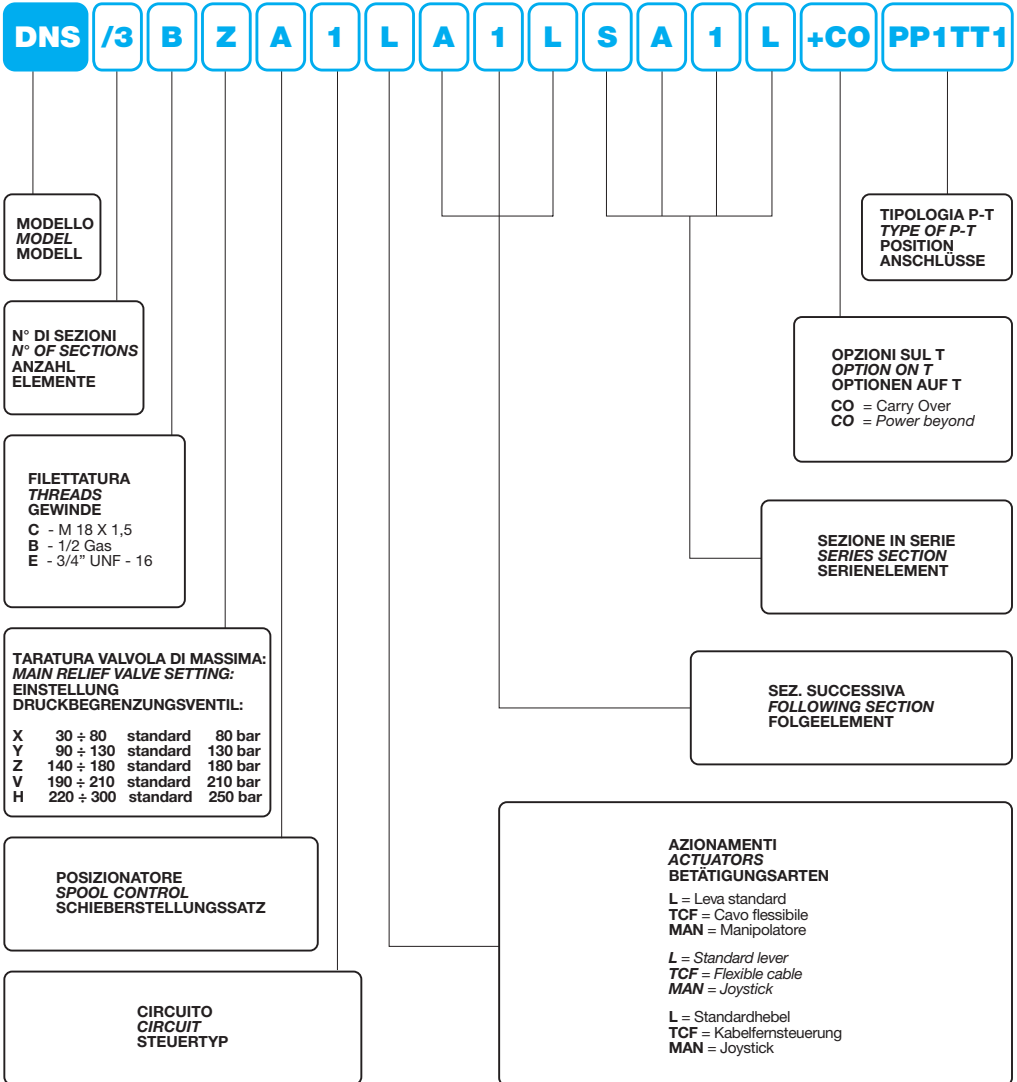

Nota: non dirigere getti d'acqua direttamente sulla valvola.
Note: do not wash the valve with direct water jet.
Bitte beachten: Steuergerät/Ventil nicht mit Hochdruckreiniger waschen.