

## 8. Transmission Pump Flow test

Note: Make sure block front wheel.

Hydraulic fluid at proper level

Make sure F-R lever, gear shift, range shift, PTO and MFWD levers are in neutral or disengaged position.

- I. Remove plug from one of port "P" (A) on control valve.
- II. Connect flow meter inlet hose and adapter to "P" port on control valve.
- III. Insert flow meter return hose into hydraulic oil fill at rear of tractor.
- IV. Fully open flow meter control valve.
- V. Start engine without depressing clutch pedal and run engine at 2400 rpm
- VI. Adjust flow meter control valve until 19.0 kgf/cm<sup>2</sup> [250 psi] shows on gauge.
- VII. Record flow, then release pressure.  
Result: if flow is less than minimum 12.0 L/min [3.17 gpm] at 2400 rpm  
The pump may be worn or damaged, requiring repair or replacement.

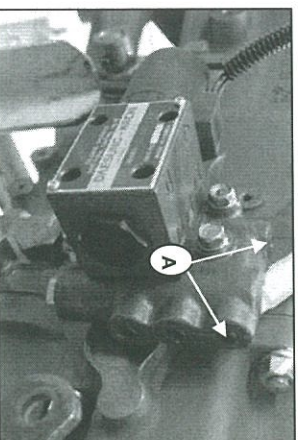

A) "P" port

## 9. Transmission Pump relief valve pressure

- I. Assemble gauge, hose and adapt.
- II. Remove plug from one of port "P" on control valve.
- III. Connect test equipment into port "P" on control valve.
- IV. Run engine at slow idle.
- V. Engage PTO switch to pressurize test out let. Hold until you hear system go into relief.
- VI. Check pressure reading on gauge.

Item	Pressure value
Transmission pump relief valve pressure	14kgf/cm <sup>2</sup> [ 199.12 psi ]

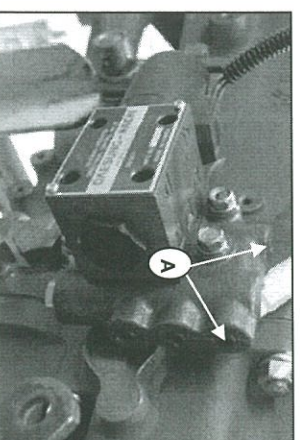

A) "P" port

# **Chapter 6**

---

## **Electrical System**



## 2. Component

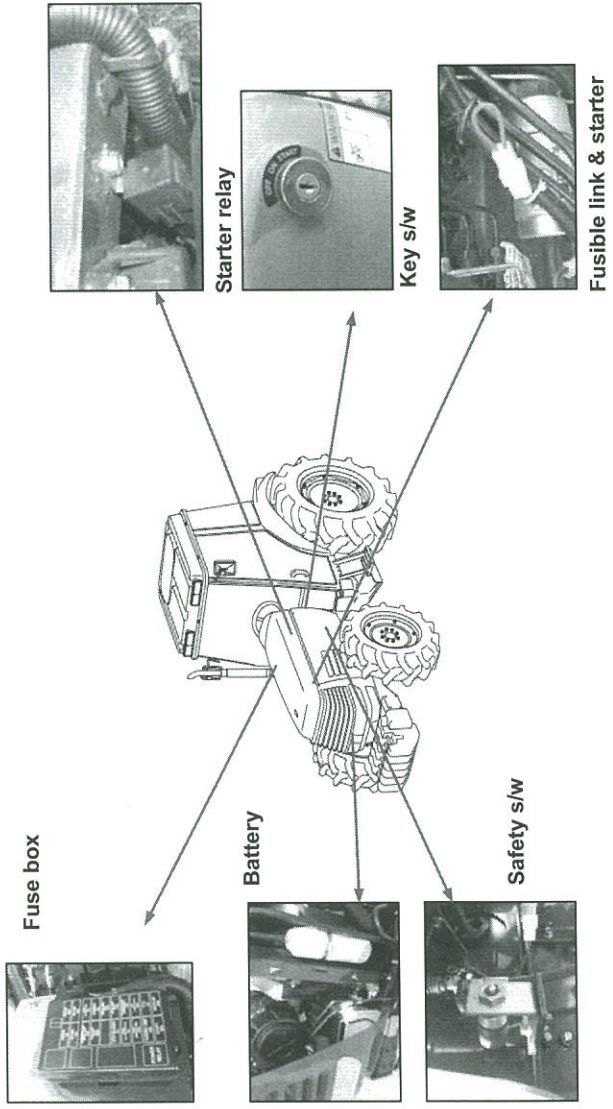

Section	Part name	Part num	Operation
Engine	Battery	TTC4020000A3	Supplies power to machine
	Fusible link	CEH3160000A4	Protects circuit from battery to fuse box.
	Fuse F01		Supplies power to starter motor solenoid.
	Starting relay [glow relay]	FTB9160000A3	Rotates starter motor
	Start safety relay [5P relay]	FTC5130000A3	Secures safety start
	Starting motor	HH20010000A1	Starts engine
	Safety switch	FTC5140000A3	Starts engine with clutch depressed
Front column	Key switch	TTC5030000B3	Controls main supply power

3. Trouble shooting

Problem	Engine won't start with chattering noise from starter						
	Engine won't start (starter motor is operating)		Engine won't start (starter motor does not operate)		Preheat lamp does not flash		Difficult start in cold weather
Inspect parts	Preheat lamp does not flash		Hold preheat lamp		Fuel stop doesn't work		
	Preheat lamp does not flash		Hold preheat lamp		Fuel stop doesn't work		
Battery	<input type="radio"/>	<input type="radio"/>	<input type="radio"/>	<input type="radio"/>	<input type="radio"/>	<input type="radio"/>	<input type="radio"/>
Fusible link	<input type="radio"/>	<input type="radio"/>	<input type="radio"/>	<input type="radio"/>	<input type="radio"/>	<input type="radio"/>	<input type="radio"/>
Fuse 01	<input type="radio"/>	<input type="radio"/>	<input type="radio"/>	<input type="radio"/>	<input type="radio"/>	<input type="radio"/>	<input type="radio"/>
Key switch	<input type="radio"/>	<input type="radio"/>	<input type="radio"/>	<input type="radio"/>	<input type="radio"/>	<input type="radio"/>	<input type="radio"/>
Safety Switch	<input type="radio"/>	<input type="radio"/>	<input type="radio"/>	<input type="radio"/>	<input type="radio"/>	<input type="radio"/>	<input type="radio"/>
Starter motor	<input type="radio"/>	<input type="radio"/>	<input type="radio"/>	<input type="radio"/>	<input type="radio"/>	<input type="radio"/>	<input type="radio"/>
Fuse F05	<input type="radio"/>	<input type="radio"/>	<input type="radio"/>	<input type="radio"/>	<input type="radio"/>	<input type="radio"/>	<input type="radio"/>
Starter relay	<input type="radio"/>	<input type="radio"/>	<input type="radio"/>	<input type="radio"/>	<input type="radio"/>	<input type="radio"/>	<input type="radio"/>
Fuse F04	<input type="radio"/>	<input type="radio"/>	<input type="radio"/>	<input type="radio"/>	<input type="radio"/>	<input type="radio"/>	<input type="radio"/>
Glow controller	<input type="radio"/>	<input type="radio"/>	<input type="radio"/>	<input type="radio"/>	<input type="radio"/>	<input type="radio"/>	<input type="radio"/>
Glow relay	<input type="radio"/>	<input type="radio"/>	<input type="radio"/>	<input type="radio"/>	<input type="radio"/>	<input type="radio"/>	<input type="radio"/>
Air heater	<input type="radio"/>	<input type="radio"/>	<input type="radio"/>	<input type="radio"/>	<input type="radio"/>	<input type="radio"/>	<input type="radio"/>
Water preheat sensor	<input type="radio"/>	<input type="radio"/>	<input type="radio"/>	<input type="radio"/>	<input type="radio"/>	<input type="radio"/>	<input type="radio"/>
Preheat lamp	<input type="radio"/>	<input type="radio"/>	<input type="radio"/>	<input type="radio"/>	<input type="radio"/>	<input type="radio"/>	<input type="radio"/>
PTO safety relay	<input type="radio"/>	<input type="radio"/>	<input type="radio"/>	<input type="radio"/>	<input type="radio"/>	<input type="radio"/>	<input type="radio"/>

#### 4.Electrical parts Inspection

##### ■ Battery

Type	MF -10 AH
Capacity	12V 110AH

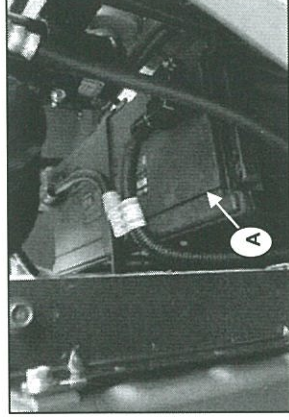

A) battery

##### ■ Fusible link

Red (R:0.85SQ) , Black (B:1.25SQ)

To inspect short

Measurement	Resist
Both connector	0 Ω

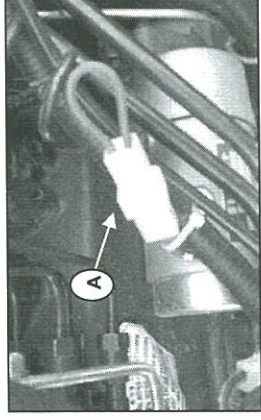

A) fusible link

##### ■ Key switch

Key switch connections

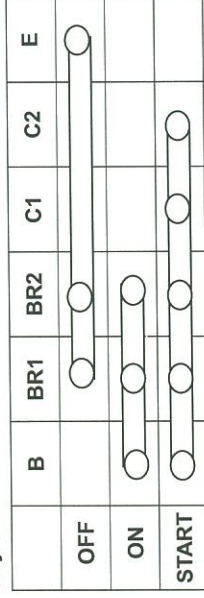

Measure A connect

	Measure		Key switch Status	Result
	+	-		
Current flow	2	3	OFF	0 Ω
	2	6	OFF	0 Ω
	3	6	OFF	0 Ω
Current flow	2	1	ON	0 Ω
	3	1	ON	0 Ω
	2	1	START	0 Ω
	3	1	START	0 Ω
	4	1	START	0 Ω
Current flow	5	1	START	0 Ω

Measure B connect

DC power	Connection		Status	Result
	+	-		
	1	Chassis ground		Around 12V



A) key switch

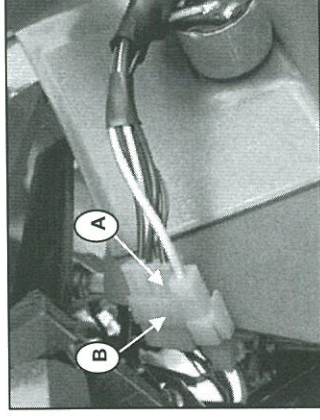

A) connector B) B connector

A connector

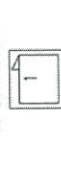

B connector (Harness)

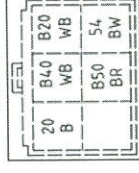
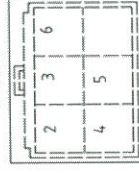

▣ Safety & PTO safety Switch

Measure A connect

Current flow	Connection		Status	Result
	+	-		
Clutch depress	1	3	Clutch depress	0 Ω
	2	4		

Measure B connect

DC power	Connection		Status	Result
	+	-		
Key switch [Start]	6	Chassis Ground	Key switch [Start]	Around 12V
	5			
Key s/w [on] PTO shift [LINK]			Key s/w [on] PTO shift [LINK]	
Current flow	4			0 Ω

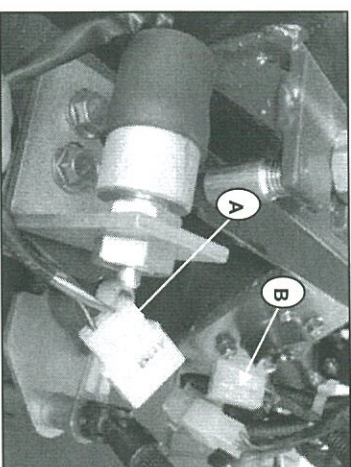

A) A connector B) B connector

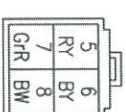
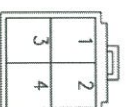

A connector

(Harness)  
B connector

▣ Starter motor

Motor measurement

DC power	Connection		Status	Result
	+	-		
Motor body	M	S	Rise pinion	0 Ω
	M	S		
	M	S		0 Ω

Measure power out on wire on chassis

DC power	Connection		Status	Result
	+	-		
Chassis ground	B	Chassis ground	Key switch [Start] & Clutch Depress	Around 12V
	M			
				Around 12V

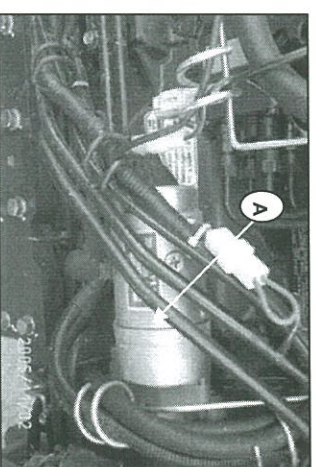

A) starter

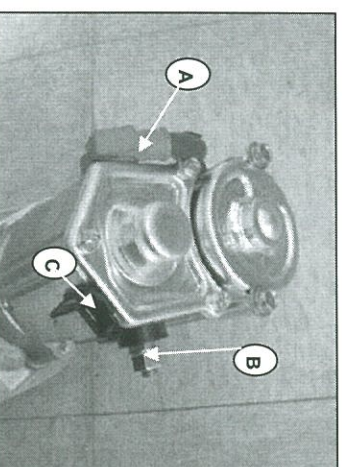

A) M connector B) B connector  
C) S connector

\*Reference (Test operation)

Battery (-) connector	Battery (+) connector	Operation
Starter motor Body	M	Rotate motor
	S	Rise pinion
	B	Does not operate
	B & S	Rise pinion and motor rotate

▣ PTO relay

	Connection		Status	Result
	+	-		
Current flow	2	3		Few $\Omega$
	1	4		0 $\Omega$
	1	5		$\infty \Omega$

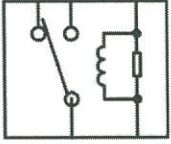

PTO relay

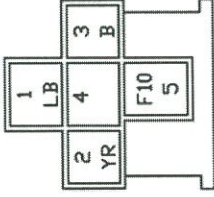

▣ Starting relay

	Connection		Status	Result
	+	-		
Resist	2	3		Few $\Omega$
Current flow	1	4		0 $\Omega$

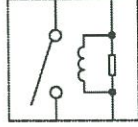

Starter relay

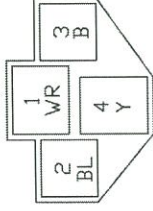



## B. Preheat Circuit

### 1. Summary

#### Air heater

Operate preheat circuit with key on

Preheating system is equipped to start the engine in low-temperatures: it consists of a timer, glow relay, glow plug, etc.

#### Operate pre-heater

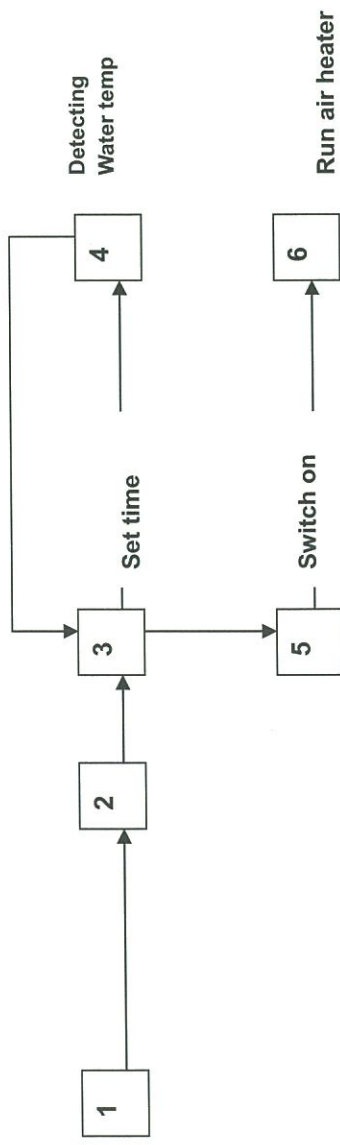

#### Operate later-heater

The heat system works to warm incoming air by means of an air heater.

This reduces white smoke and nasty smell after starting engine in cold weather.

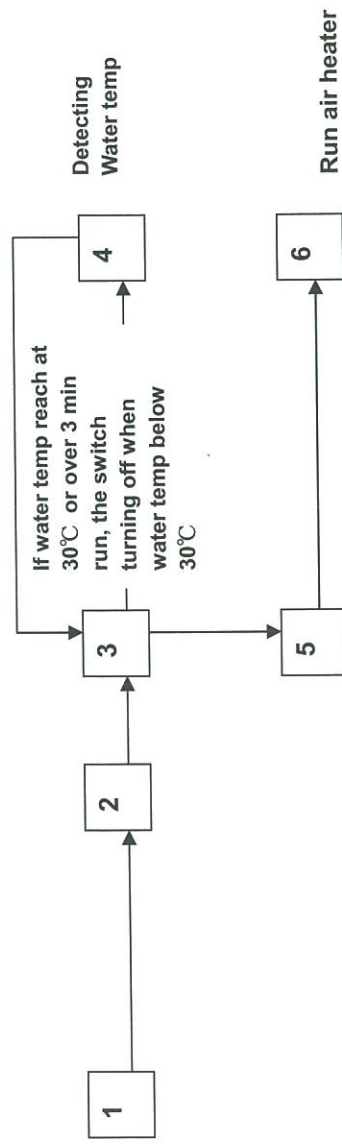

2. Diagram

2.1 6530(R) circuit

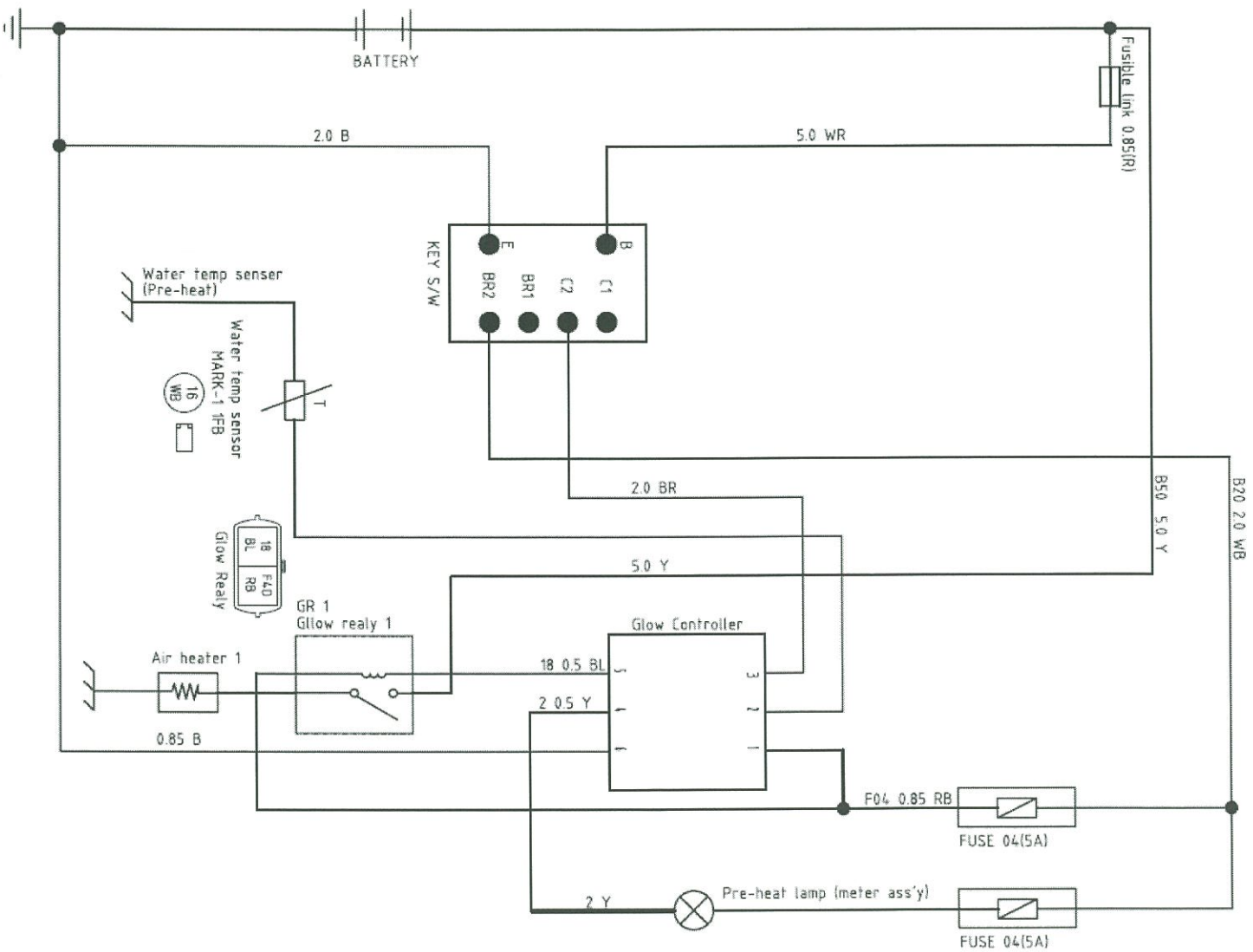

2.2 5530(R) circuit

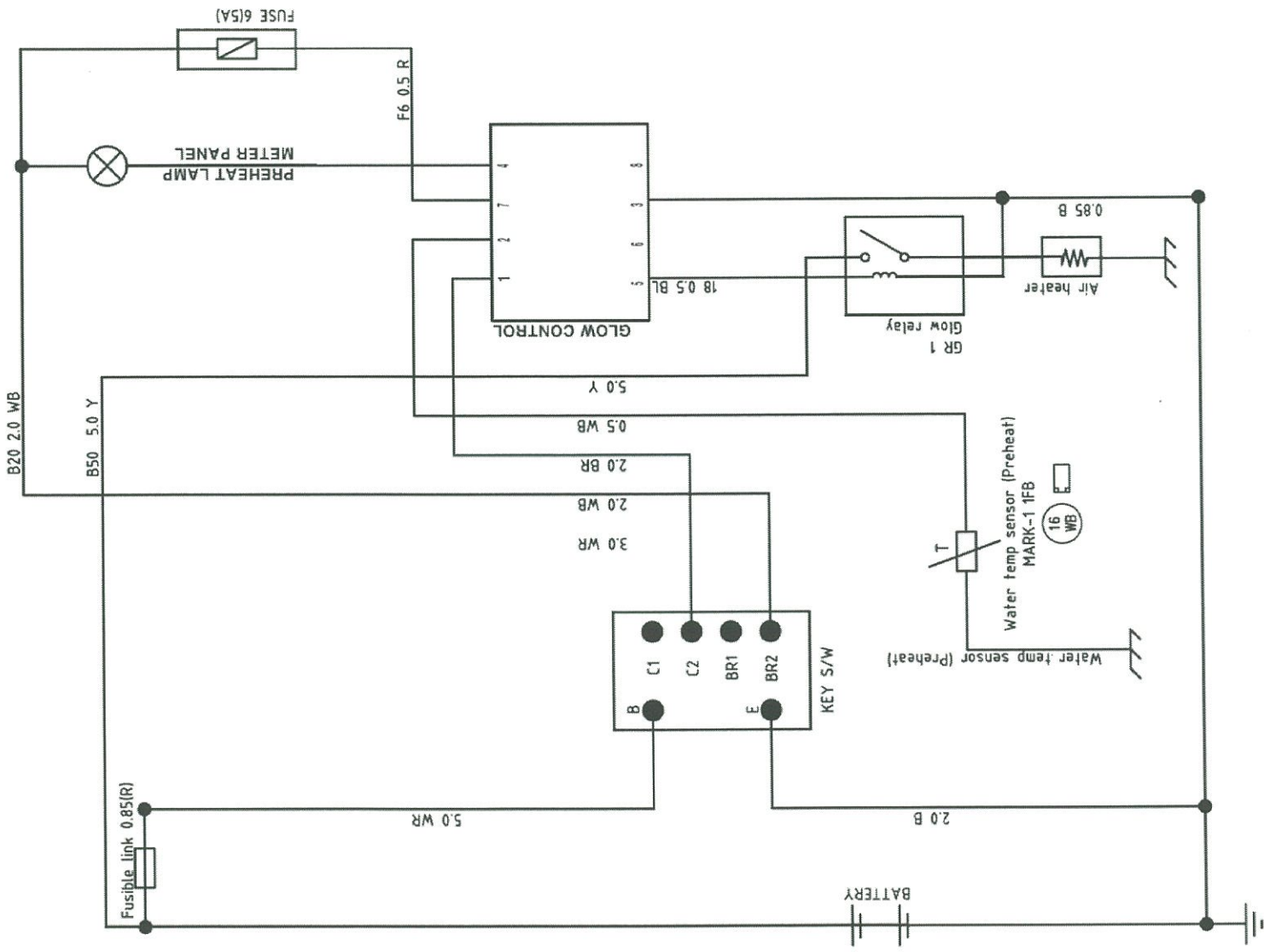

3. Component

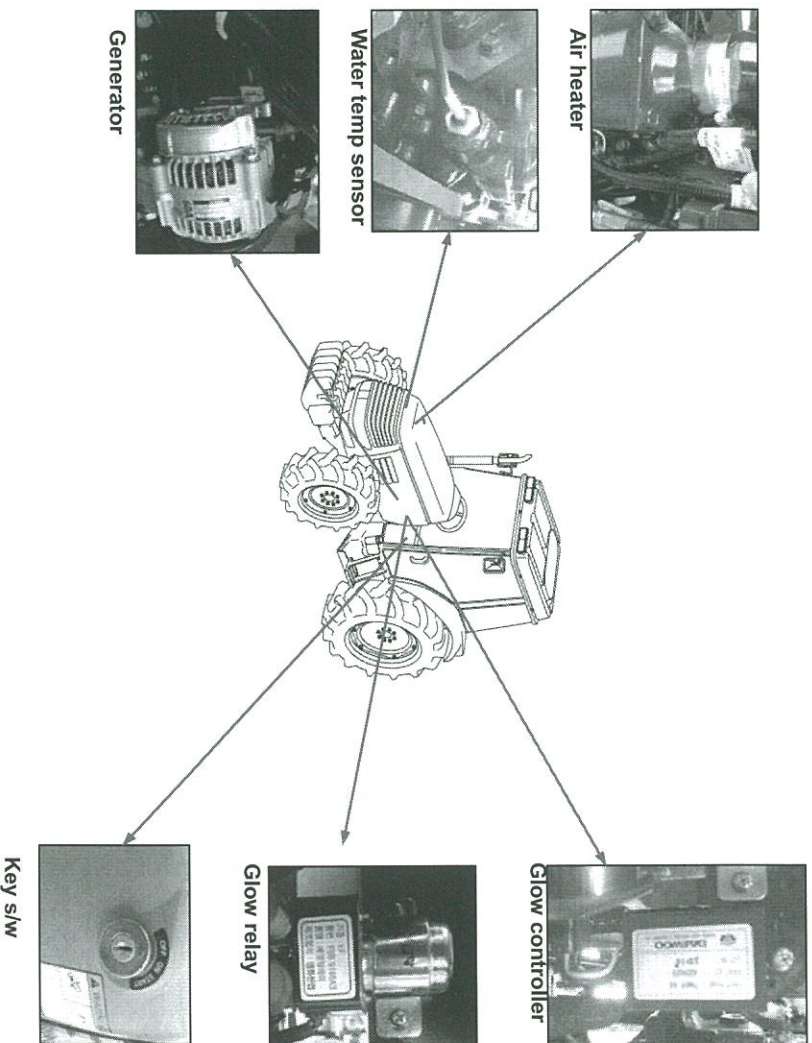

Section	Part name	Part num	Operation
Engine	Fuse F 04		Supplies glow controller power
	Controller	FBB9170000A3	Controls glow plug work time
	Glow relay	FBB9160000A3	Operates air heater
	Air heater	C6008157310	Warmns air
	Water temp sensor	FBV2190000A3	Detects water temp
	Generator	C6008611611	Charges battery
Front column	Key switch	TTC5030000B3	Supplies power with switch on and clutch depressed.

#### 4. Electric parts inspection

##### ■ Fuse box

Reference 7-8 page

##### ■ Glow controller

Measure B connect

	Connection		Status	Result
	+	-		
DC power	1		Start switch start	Around 12 V
Resist	2		0 °C: 5.11kΩ Water temp sensor	Resist valve change according to water temp
DC power	3	Chassis Ground	Key switch on	Around 12V
DC Power	4		Key switch on	Around 12V
	5		Key switch on	12 V
Current flow	6		Key switch on	0 Ω

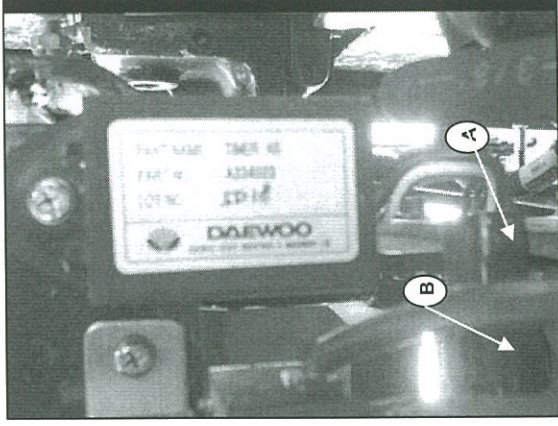

A) A connector B) B connector

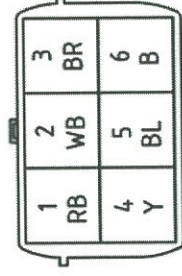

B connector  
(Harness)

▣ Air heater

Measure Air heater connector

	Connection		Status	Result
	+	-		
Resist	1	Chassis Ground		Around 0.1~0.2 Ω

Measure chassis wiring

	Connection		Status	Result
	+	-		
Resist	2	Chassis Ground	Key switch [on] Preheat lamp [on]	Around 12V .
		Key switch [on] Preheat lamp [Off]	Around 12V .	

\* Make sure when disconnecting connector to measure and be careful with short wire.

▣ Glow relay

Measure A connector

	Connection		Status	Result
	+	-		
Resist	1	2	Stop	Around 40Ω

Measure B connector

	Connection		Status	Result
	+	-		
DC Power	3	Key switch off		Around 12V
DC Power	4	Chassis Ground	Key switch [on] Preheat lamp [on]	12V
		Key switch [on] Preheat lamp [off]	0V	

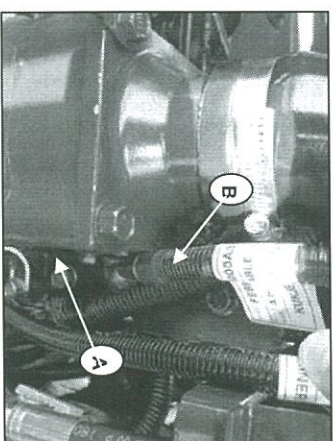

A) A connector B) B connector



A) A connector

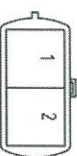

A connector

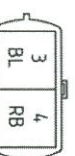

B connector (Harness)

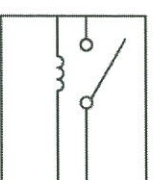

■ **Water temp sensor (pre-heat)**

Measure water temp sensor

	Connection		Result
	+	-	
Resist	1	Chassis Ground	Changes resist valve according water temp

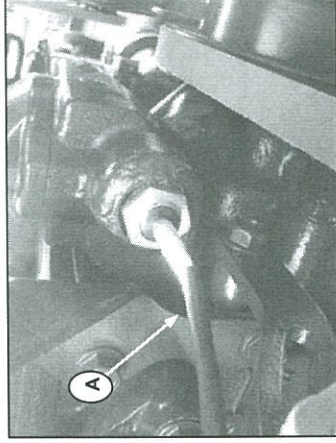

A) A connector

Reference

Temp(0℃)	-30	-20	0	20	40	60	80	90
Resist value(kΩ)	19.5	12.1	5.11	2.39	1.21	0.65	0.38	0.29

Measure harness wiring

	Connection		Status	Result
	+	-		
DC power	2	Chassis Ground	Key switch [on]	Changes resist valve according water temp

C. Fuel stop & Charging circuit

1. Summary

Charging circuit consists of battery, generator, starting switch, charging lamp, etc.

2. Diagram

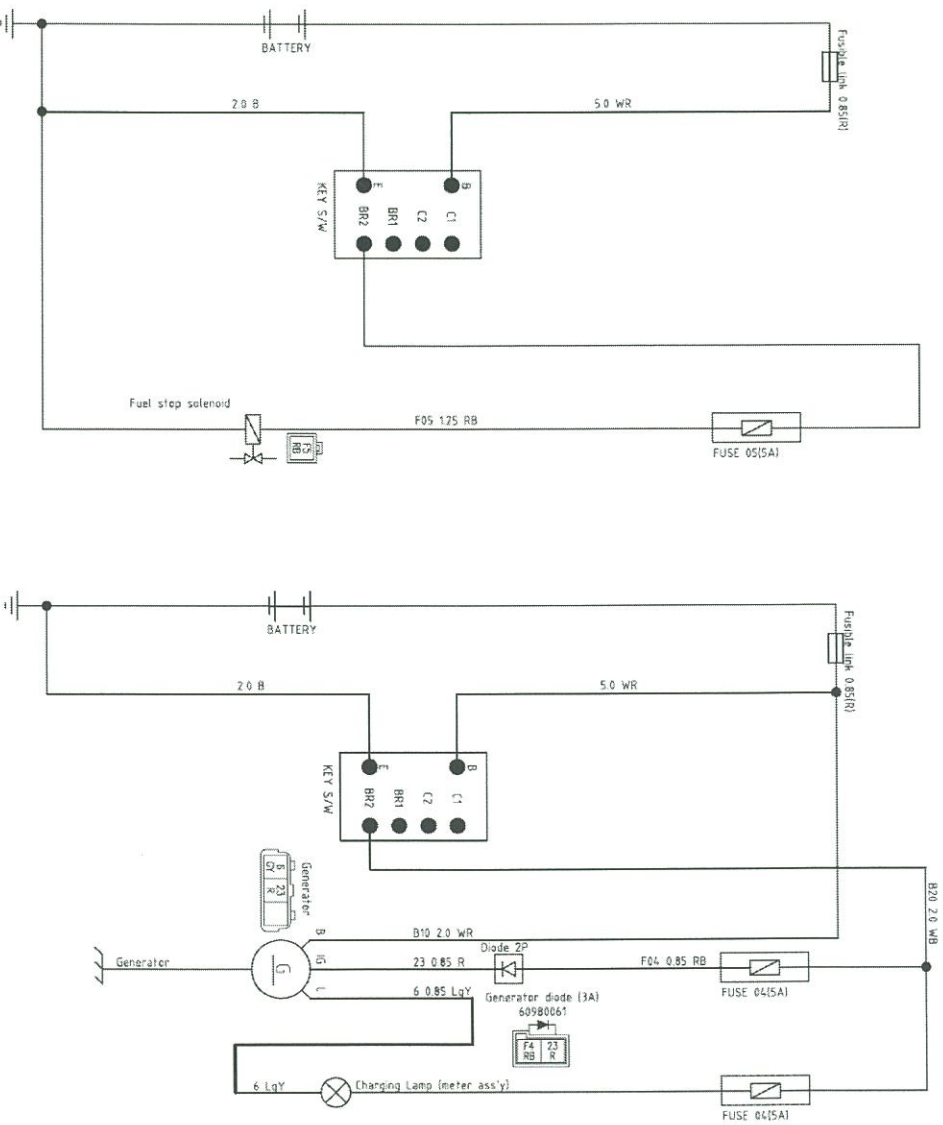

### 3. Component

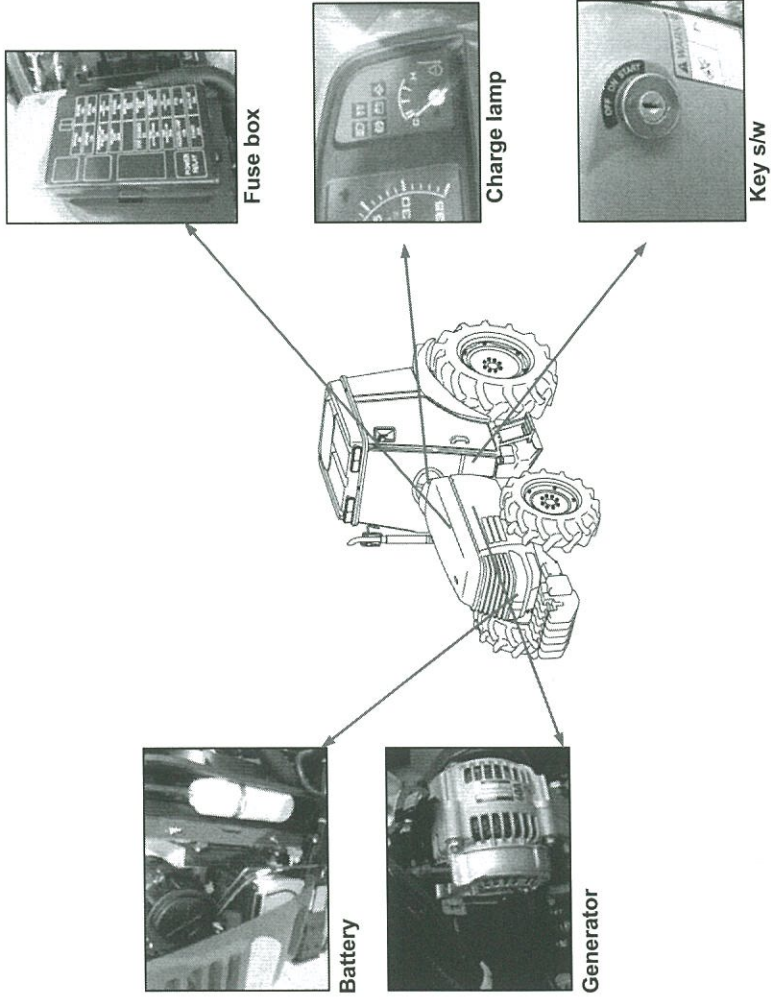

Section	Part name	Part num	Operation
Engine	Battery	TTC402000A3	Supplies electric power to machine
	Generator	C6008611611	Charges battery
	Fuse F04		For a generator and charge lamp
Front column	Key switch	TTC5030000B3	Supplies power with switch on and off
	Charge lamp (Meter ass'y)	FBD4190200A9	Indicates charging status

4. Trouble shooting

	The engine does not start, battery discharged.				Generator operates, but battery is not charging
	Battery electrolyte is reduced quickly.				
	Charging lamp does not turn-off		Charging lamp does not turn-on		
	Preheat lamp does not flash				
Drive valve	<input type="radio"/>	<input type="radio"/>	<input type="radio"/>	<input type="radio"/>	
Generator	<input type="radio"/>	<input type="radio"/>	<input type="radio"/>	<input type="radio"/>	
Charge lamp			<input type="radio"/>		
Battery	<input type="radio"/>	<input type="radio"/>		<input type="radio"/>	
Fuse F04	<input type="radio"/>			<input type="radio"/>	

Note: When the battery is removed and reinstalled, make sure to connect wires in proper polarity.

On a generator B connector always hot, So use caution to prevent a short on the chassis.

Make sure that disconnect battery connector when you quick charging a battery, due to the possibility of damage to a generator diode.

Avoid exposure of electrical parts to water, whenever possible, as it can lead to electrical equipment damage.

## 5. Electric parts inspection

### ■ Battery

Reference 7-5 page

### ■ key switch

Reference 7-5 page

### ■ Fuse

Reference 7-8 page

### ■ Charging lamp on instrument panel

Charge lamp automatically turns off as long as the charging circuit is operating properly.

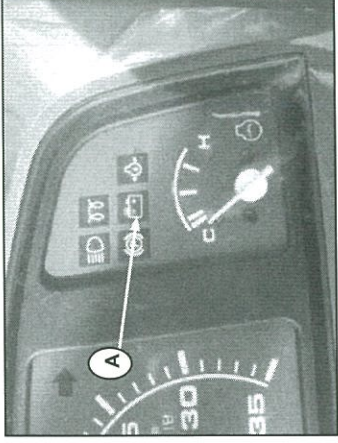

A) Charging lamp

### ■ Generator

Generator is equipped with IC regulator.

Generator output is D.C.

1. Connect the same pole to the IC-connector and L-connector.
2. Do not directly connect between the IC and L connectors.  
(Always connect through the charging lamp.)
3. Do not connect any kind of load between L and E.
4. Do not connect inductive or quantitative load to L connector  
(such as a relay coil.)
5. Do not disconnect battery and/or B connector during the operation of the generator.

**Note: normally Battery voltage is 14.5 ± 0.5V**

**Measure C connector [connect connector]**

	Connection		Status	Result
	+	-		
DC Power	C	Chassis Ground	Key switch off	Around 12V

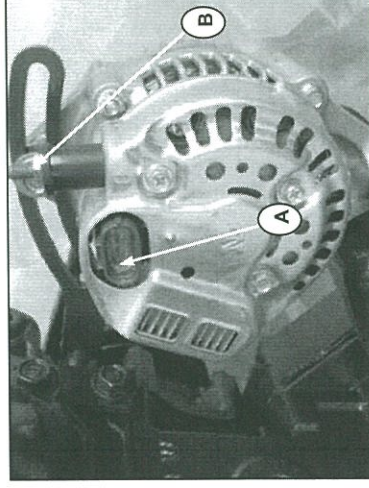
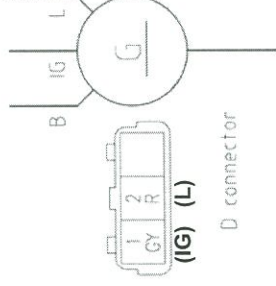

A) A connector  
B) B connector

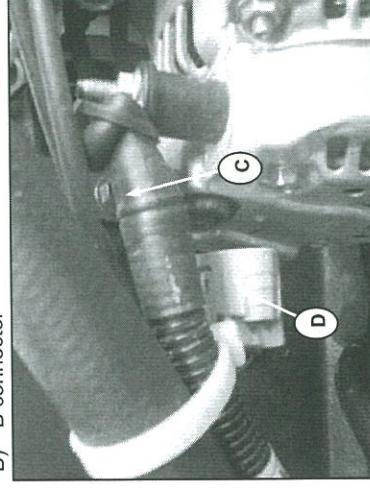

C) C connector  
D) D connector

**Measure D connector with disconnect**

	Connection		Status	Result
	+	-		
DC Power	1	Chassis Ground	Key switch on	Around 12V
	2			

D. Warning circuit

1. Diagram

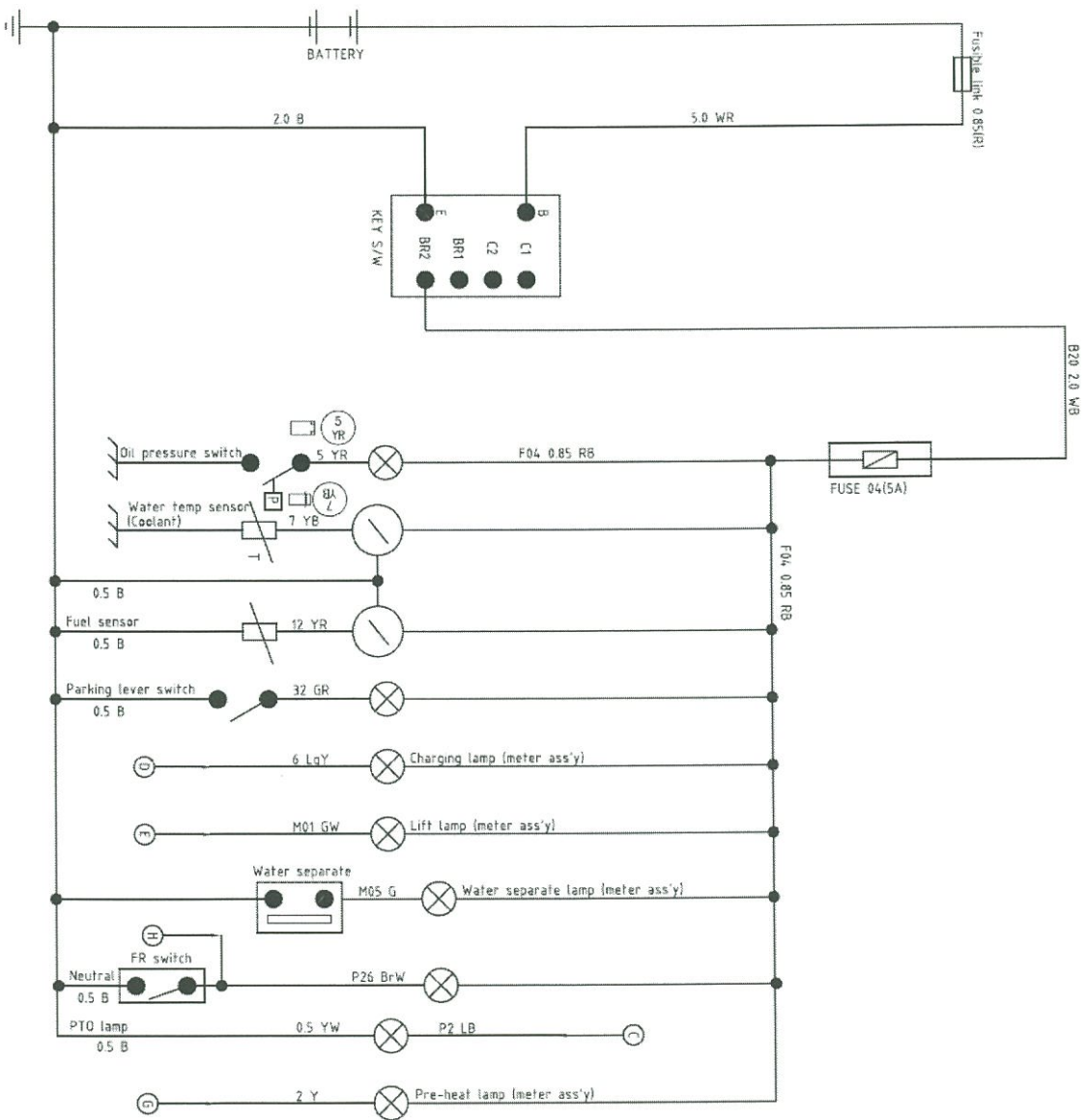

## 2. Components

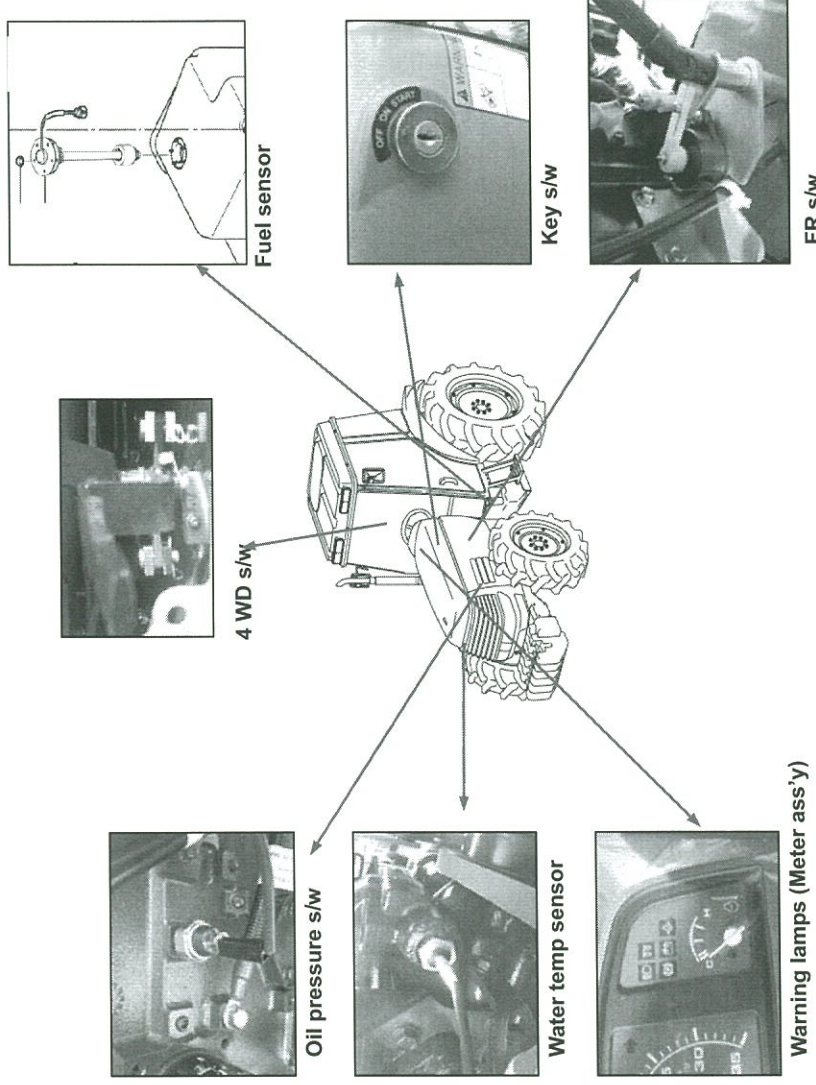

Section	Part name	Part num	Operation
Engine	Fuse F04		Protects circuit
	Oil pressure switch	HA09250000A3	Indicates low hydraulic oil by flashing lamp
	Water temp sensor	FBV2190000A3	Indicates coolant temp
Front column	Key switch	TTC5030000B3	Supplies power
	Meter ass'y	FBV4190200A9	Indicates alert
	FR switch	TCD9110000B2	Indicates gear shift neutral
Mission	Fuel sensor	FBD4280000A2	Indicates fuel level
	4WD switch	CQG8030000A3	4WD lamp on when switch is on
	Park switch	TZC5110000A3	Operates park lamp

3. Electric parts inspection

- ▣ **Key switch**  
Reference 7-5 page
- ▣ **Fuse 10A**  
Reference 7-8 page
- ▣ **Instrument panel**

Measurement instrument panel connector

	Connection		Status	Result
	+	-		
DC Power	1		4WD lever [On]	Around 12V
Current flow	2		Shuttle lever [N]	0 Ω
Current flow	3		Engine stop	0 Ω
Resist	4	Chassis Ground	Change resist value	F: 3 Ω E: 110 Ω
Resist	5		Change resist value	80 °C 118±6 Ω
DC power	6		Key switch on	Around 12V
Current flow	7			0 Ω

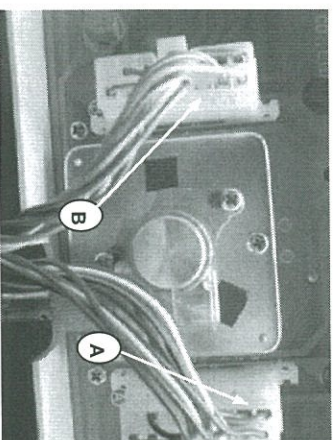

E) A connector B) B connector

Meter ass'y A  
(Harness)



Meter Ass'y B  
(Harness)

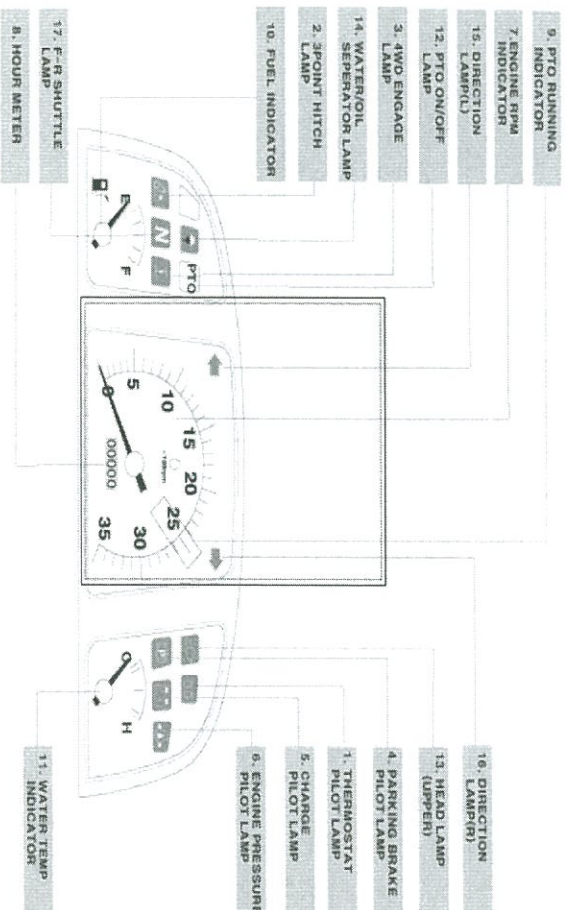
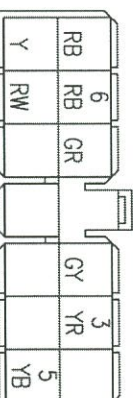

■ 4WD switch

Measurement A connect

Resist	Connection		Status	Result
	+	-		
1	2	-	4 WD lever [on]	0 Ω
		4 WD lever [off]	∞ Ω	

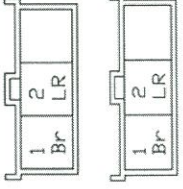

A connector  
4WD switch

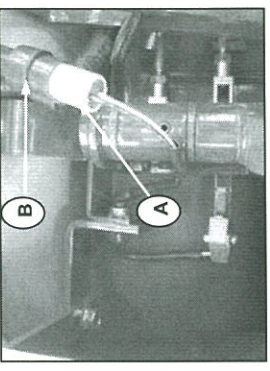

A) A connector B) B connector

■ FR switch

Measurement A connector

Resist	Connection		Status	Result
	+	-		
2	4	-	Shuttle [N]	0 Ω

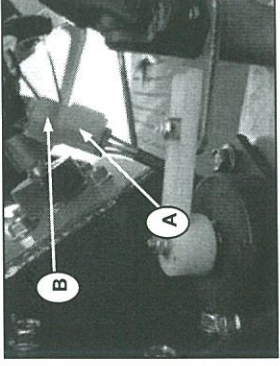

A) A connector B) B connector

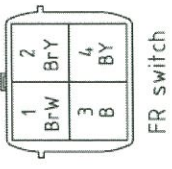

FR switch

■ Oil pressure switch

\*warns of oil pressure and activates the lamp, indicating if the oil pressure is under pressure level.

Setting of oil pressure switch	05 ± 0.1 (kgf/cm2)
--------------------------------	--------------------

Measurement connector

Resist	Connection		Status	Result
	+	-		
A	Chassis ground	-	Engine [stop]	0Ω
		Engine [run]	∞ Ω	
DC power	B	-	Oil lamp [on] key switch [On]	12V

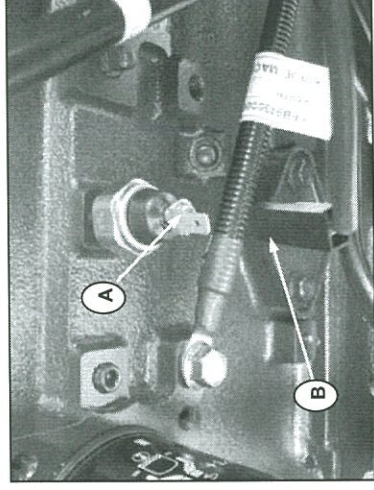

A) A connector B) B connector

■ Fuel sensor

\*Key switch "ON"

Fuel tank contains a combination unit: float and variable resistor. If the fuel tank is full, value of variable resistor is 0 Ω, and current is grounded at L1, resulting in the needle rotating to indicate F. If the fuel level is low, float moves downward, and the value of the variable resistor is higher than L2, Resulting in the current flow changing from L1 to L2, thus magnetizing L2, which causes needle to rotates to E on the indicator.

F: Full

E: Empty

Measurement A connector

	Connection		Status	Result
	+	-		
Resist	1	2	Fuel level	0 Ω
			[F]	
			[1/2]	32.5 Ω
			[E]	100 Ω

Measurement B connector

	Connection		Result
	+	-	
Resist	3	Chassis ground	0 Ω
DC power	4		Switch [on] DC 7.4V & 0.12A Fuel gauge move to [F]

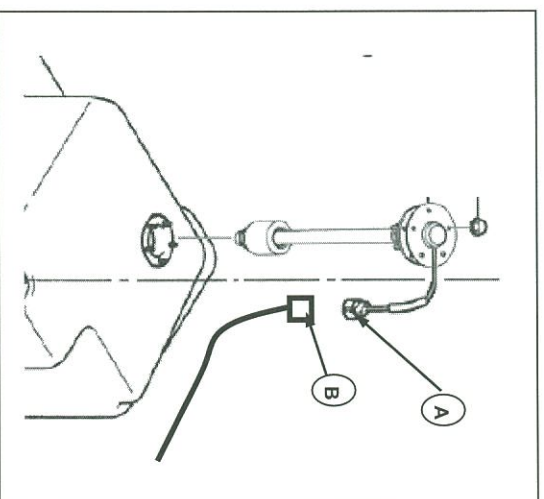

A) A connector B) B connector

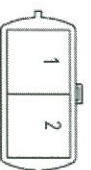

A connector

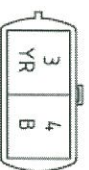

B connector



2. Component

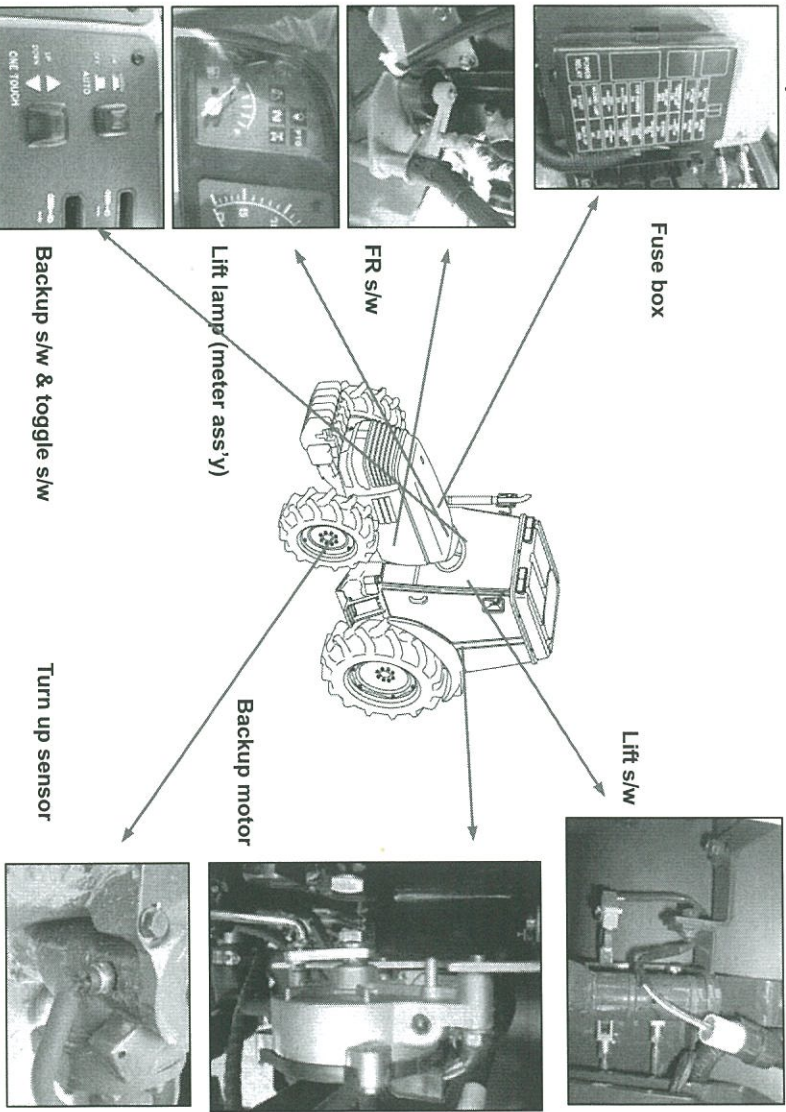

Section	Part name	Part num	Operation
Engine	Fuse F04		For lift lamp operation
	Fuse		Supplies power to backup motor
	Lift lamp (Meter ass'y)	FBD4190200A9	Show back up motor operation
Front column	FR switch	TCD9110000B2	When driving backward, the rear application will go up
	Toggle switch (up & down)	TCE2130000A4	Control rear application lift and down
	Back up lamp switch	TCE2090000A3	Sets backup status
	Lift switch	TCE2180000A4	Lift down with position lever, r switch go up by the backup motor
	Backup unit	FTC5430000A2	Controls backup motor
Mission	Backup motor	TCE2120000A1	Changes hydraulic direction by operating control valve
	Turn up sensor	FT1927/0000B3	Turns up sensor operating at end of steering

### 3. Electric parts inspection

■ **Fuse**

Reference 7-8 page

■ **F-R switch**

Reference 7-22 page

■ **Toggle switch (up/down)**

Measurement A connector

	Connection		Result
	+	-	
Resist	2	1	Switch down 0 Ω
	3	1	Switch up 0 Ω

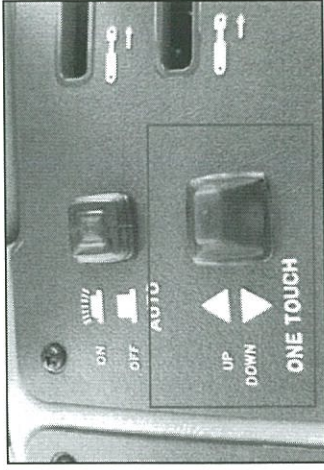

Measurement B connector

	Connection		Status	Result
	+	-		
Resist	4	Chassis ground		0 Ω
DC power	5	Chassis ground	Key switch [On]	DC 12C
DC power	6	Chassis ground	Key switch [On]	DC 12V
DC current	5	4	Key switch [On]	Around 0.02A Motor go up
DC current	6	4	Key switch [On]	Around 0.02A Motor down

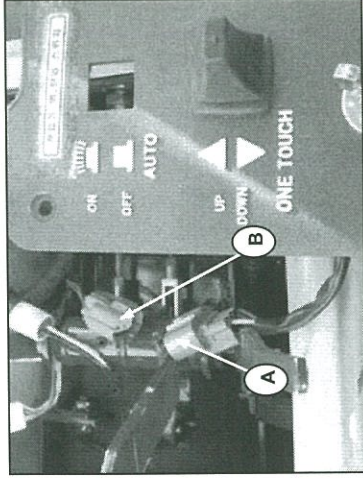

A) A connector B) B connector

A connector

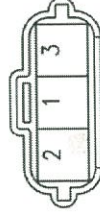

B connector  
(Harness)

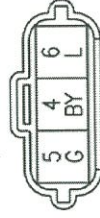

▣ Lift switch (P lever s/w)

Measurement

	Connection		Status	Result
	+	-		
Resist	1	2	Position lever raised	0 Ω

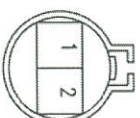
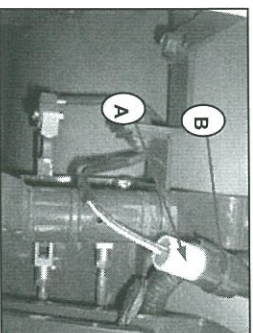

A connector

B) A connector B) B connector

▣ Back up switch  
Measurement

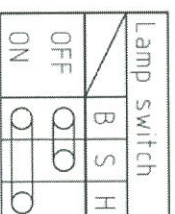
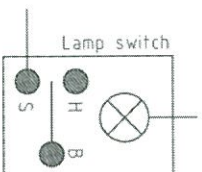
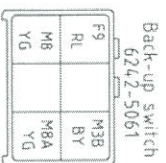
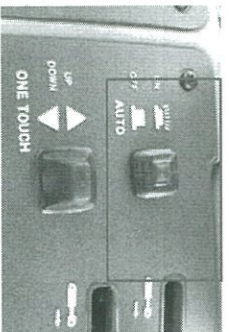

▣ Back up Controller

Measurement A connector (chassis)

	Connection		Status	Result
	+	-		
Resist	1	7	Backup motor down position	0 Ω
	2	7	Backup motor raised position	∞ Ω
DC current	3	Chassis ground	Key switch [On]	0.2 A & lift lamp on
Resist	4	Chassis ground		
	5	Chassis ground	Key switch [Off]	12V
DC power	6	Chassis ground	Key switch [On]	12V
	9	8		Around 0.8 Ω

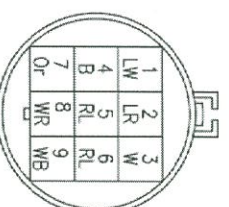

A connector

**Measurement B connector**

	Connection		Status	Result
	+	-		
Resist	10	11	Key switch [Off] Shuttle lever [R]	0 Ω
	12	11	Key switch [Off] Toggle switch [raise]	0 Ω
	13	11	Key switch [Off] Backup release [On]	0 Ω
	14	11	Key switch [Off] Toggle switch [down] Position lever [max up]	0 Ω

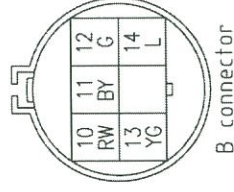

B connector

**Back up motor**

**Measurement A connector**

	Connection		Status	Result
	+	-		
Resist	2	1		0 Ω
	3	4	Motor [raise]	0 Ω
	3	4	Motor [down]	0 Ω

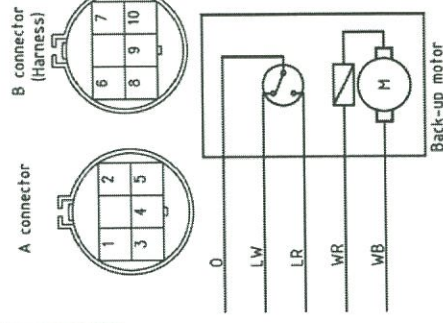

Back-up motor

**Measurement B connector**

DC power	Connection		Status	Result
	+	-		
	9	Chassis ground	Key switch [on]	Around 12V

**Turn up sensor**

**Measurement A connector**

Resist	Connection		Status	Result
	+	-		
1	2		Over turning angle 30 degree	0 Ω

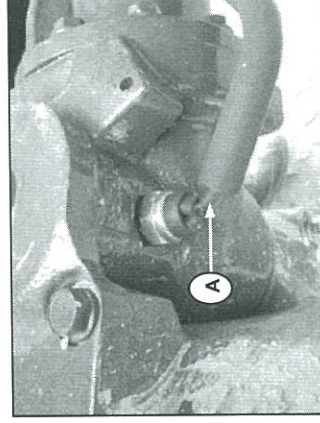

A) A connector

F. Horn & lamp circuit

1. Diagram

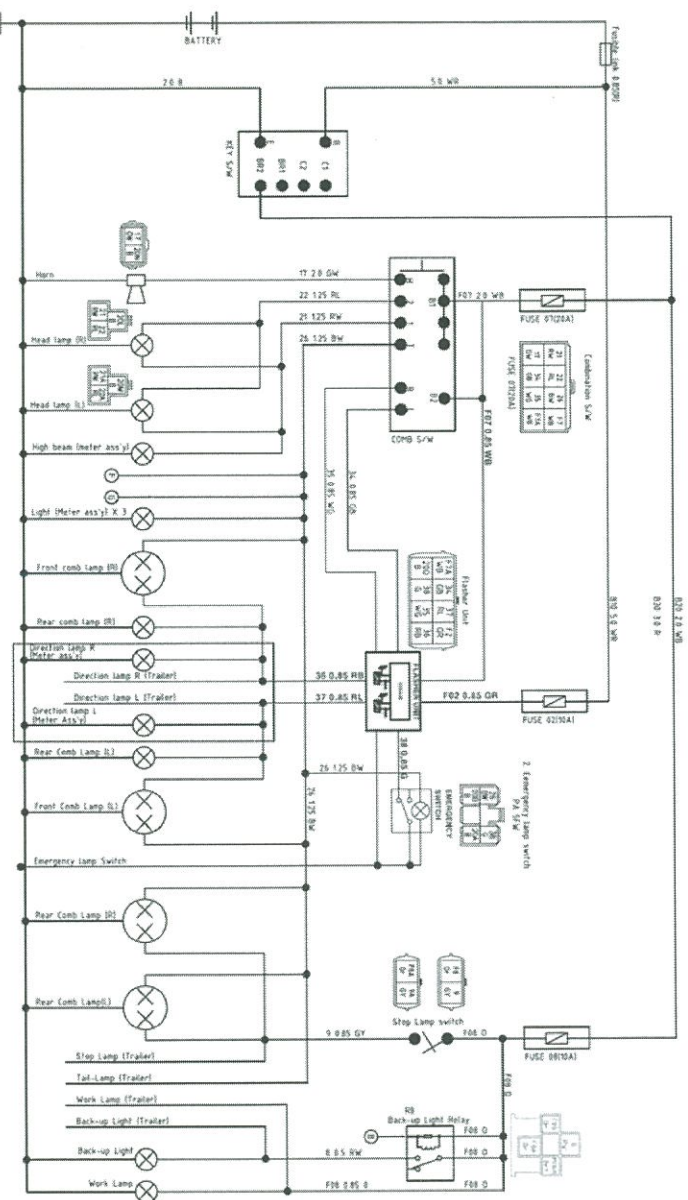

## 2. Component

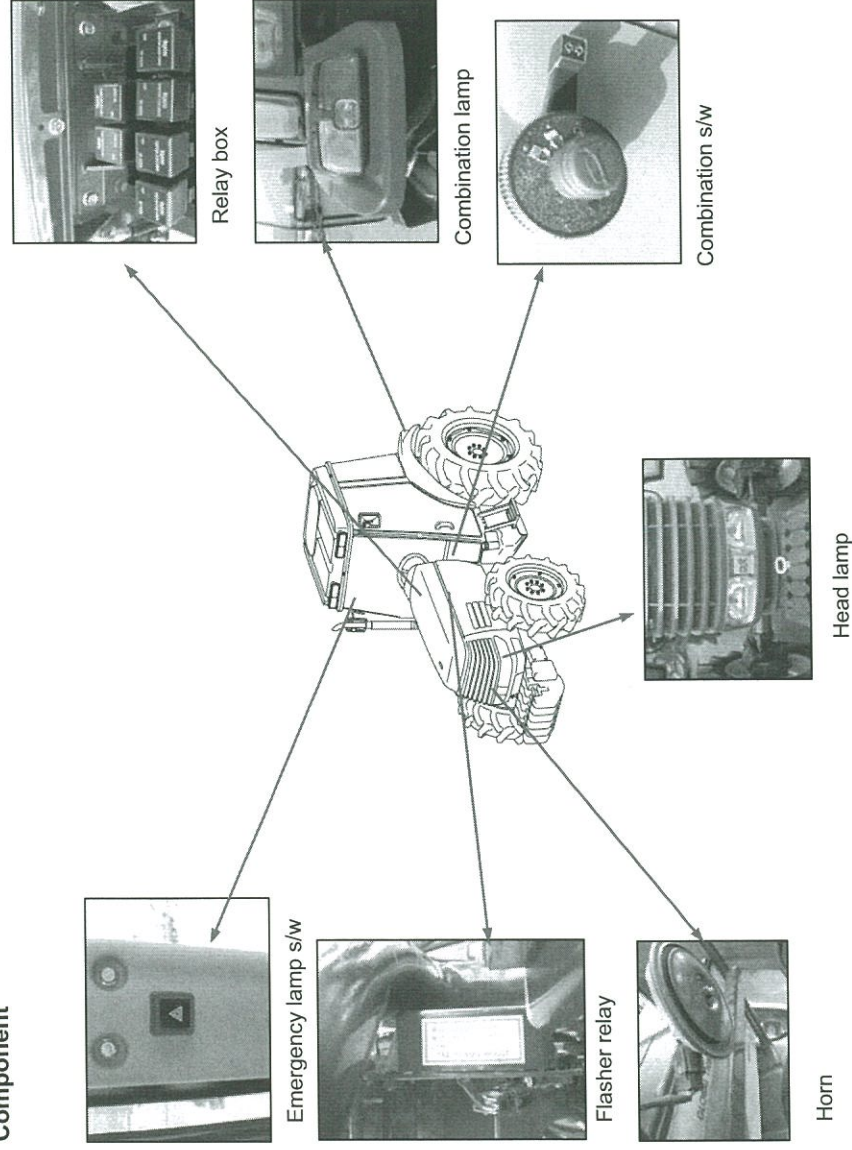

Section	Part name	Part num	Operation
Engine	Fuse F07 [20A]		Supplies power to horn and head lamps
	Fuse F02 [10A]		Supplies power to emergency and direction lamps
	Fuse F08 [10A]		Supplies power to Stop and back up light
	Direction lamp relay [Flasher relay]	NTC5130000A3	Flashing direction lamps
	Emergency lamp relay [Relay 5p]		
	Emergency lamp switch	FBK3510000A3	
Front column	Combination lamp switch	CBF3010000A2	
	F-R switch	TCD9110000B2	Back up relay working
	Direction lamp	FBE1300000A3	
Cabin	Combination lamp (Back up light)	FBD2160000A3 FBD2170000A3	Lamp on at reverse
	Head lamp	Fbd6800400a2	
Front mask	Horn	TTD1040000B3	

### 3. Electric parts inspection

- Fuse box**  
Reference 7-8 page
- Emergency lamp relay**  
Reference 7-8 page
- Back up relay**  
Reference 7-8 page
- Emergency lamp switch**  
Reference 12 page
- F-R switch**  
Reference 7-22 page
- Direction lamp relay**

#### Measurement A connector

	Connection		Status	Result
	+	-		
Resist	1	2		0 $\Omega$

#### Measurement B connector [Fuse box]

	Connection		Status	Result
	+	-		
DC power	5	Chassis Ground	Key switch [On]	Around 12V
Resist	3	Chassis ground		0 $\Omega$

■ Combination switch

Measurement A connector

	Connection		Status	Result
	+	-		
Resist	8	1	Horn [Press]	0 Ω
	2	1	Light switch [Lo] [H1]	0 Ω
	3	1	Light switch [H1]	0 Ω
	4	1	Light switch [Lo]	0 Ω
	6	5	Direction switch [R]	0 Ω
	7	1	Direction switch [L]	0 Ω

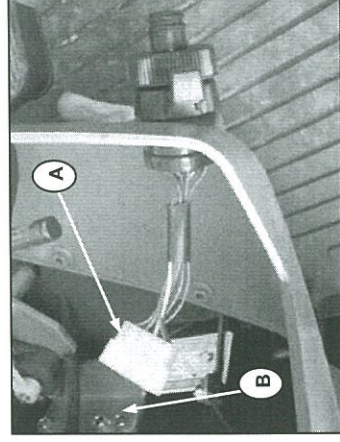
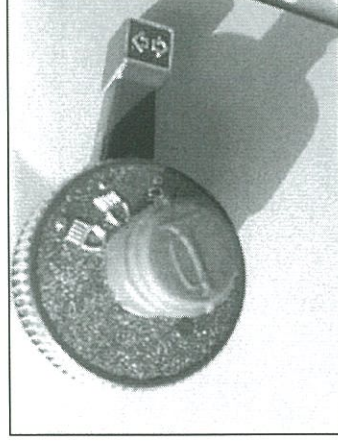

Measurement B connector

	Connection		Status	Result
	+	-		
DC power	12	Chassis ground	Key switch [On]	Around 12V
	16			
DC current [key switch on]	12	9	Hi beam [On]	Around 4A
	12	10	Low beam [On]	
	12	11	Tail-light [On]	Around 0.5A
	12	13	Horn working	
	16	14	Direction lamp [L]	Around 2.5A
	16	15	Direction lamp [R]	

B) A connector B) B connector

A connector

1	2	3	4
5	6	7	8

B connector

9	10	11	12
RW	RL	BW	WB
13	14	15	16
GW	GB	WG	WB

Switch connection diagram

Light switch				Direction lamp				Horn switch			
Wire color	R	RG	RW	RY	Wire color	G	WG	GB	Wire color	R	GW
Connector	R	T	1	2	Connector	R2	R	L	Connector	R	GW
Status	1				Status				Status		
OFF					1(R)	◆	◆		FREE	◆	
1	◆	◆			OFF				PUSH	◆	◆
2	◆	◆	◆	◆	2(L)	◆		◆			

Note: Starting switch is selected "ON", when combination switch moves, the first stage of right side the head lamp is turned on high-beam, in case of the second stage turns on the head lamp low-beam. At the first and second stage, turn on the tail lamp and side lamp.

Rear combination lamp

Measurement A connector

	Connection		Status	Result
	+	-		
Resist	1	5	Stop lamp on	Few Ω
	2	5	Direction lamp on	
	3	5	Tail-light on	
	4	5	Back up light	

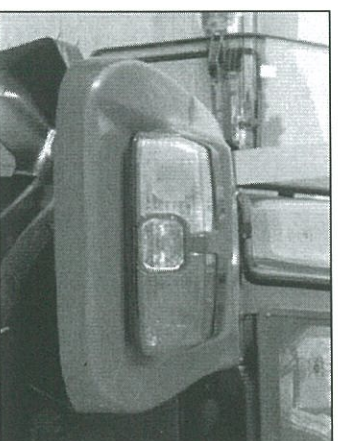

Measurement B connector

	Connection		Status	Result
	+	-		
DC power	6	Chassis ground	Key switch [On]	12V
	7		Tail-light [On]	
	8		Direction lamp	
	9		Key switch [On]	
	10		Stop lamp [On]	
Resist	9	Chassis ground	Key switch [On]	0Ω
	10		Backup light [On]	

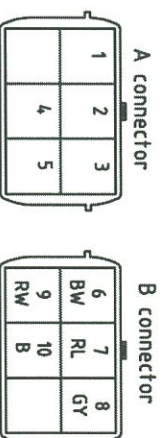

▣ Head lamp L,R

Measurement A connector

	Connection		Status	Result
	+	-		
Resist	2	1	Head lamp [High beam]	Few $\Omega$
	3	1	Head lamp [Low beam]	

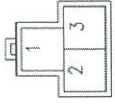

A connector

Measurement B connector

	Connection		Status	Result
	+	-		
Resist	4			0 $\Omega$
DC power	5	Chassis ground	Key switch [On], head lamp [H1]	12V
	6		Key switch [On], head lamp [Lo]	

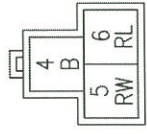

(harness)  
B connector

▣ Horn

Measurement A connector

	Connection		Status	Result
	+	-		
Resist	2	1		Around 4.7 $\Omega$

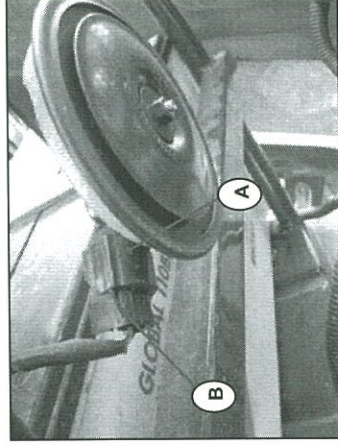

C) A connector B) B connector

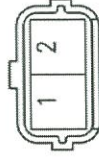

A connector

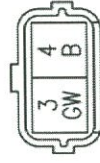

B connector (harness)

Measurement B connector

	Connection		Status	Result
	+	-		
Resist	3	Chassis ground	Key switch [On], Horn working	Around 4.7 $\Omega$
	4			

G. PTO circuit

1. Diagram

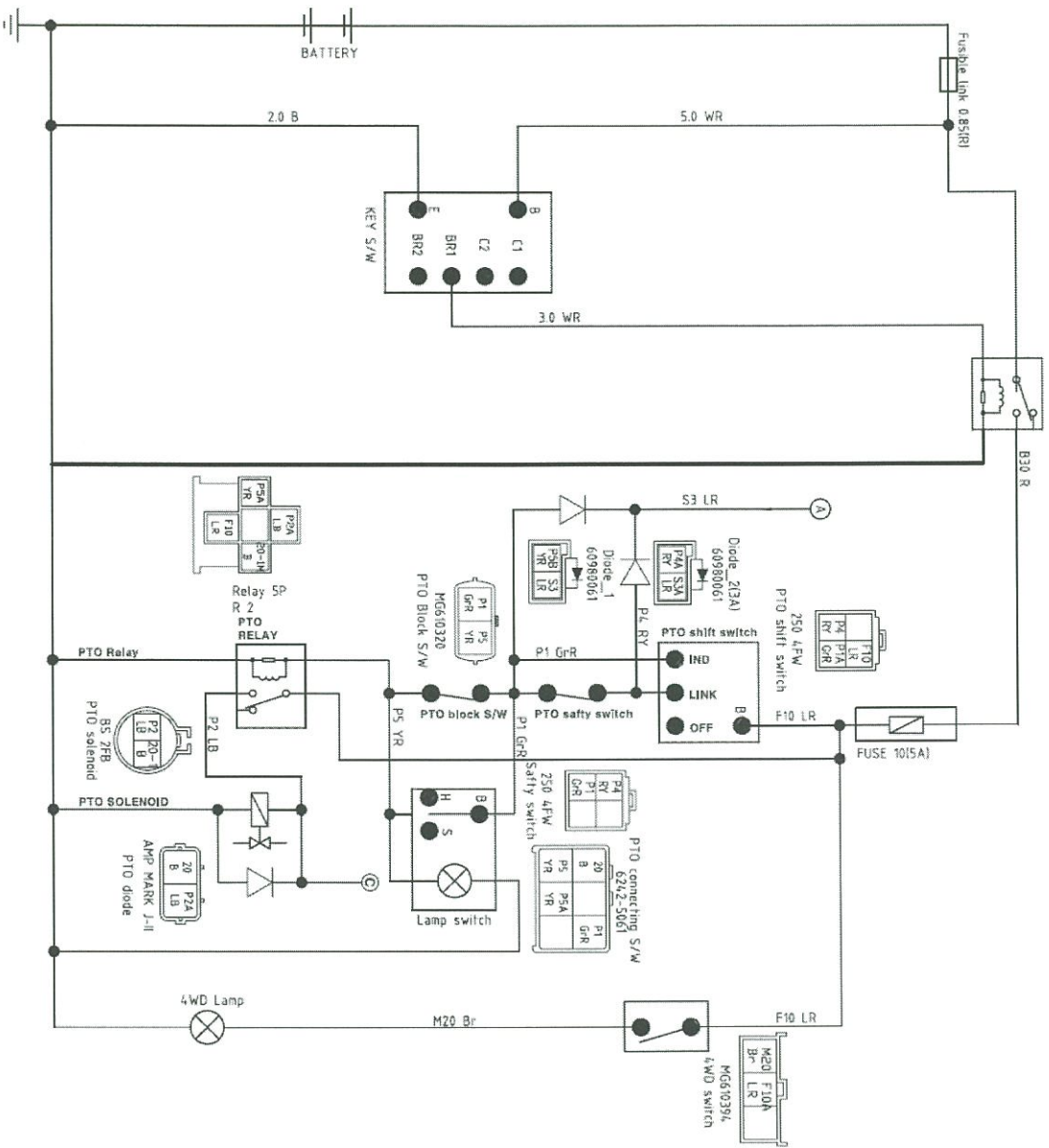

## 2. Component

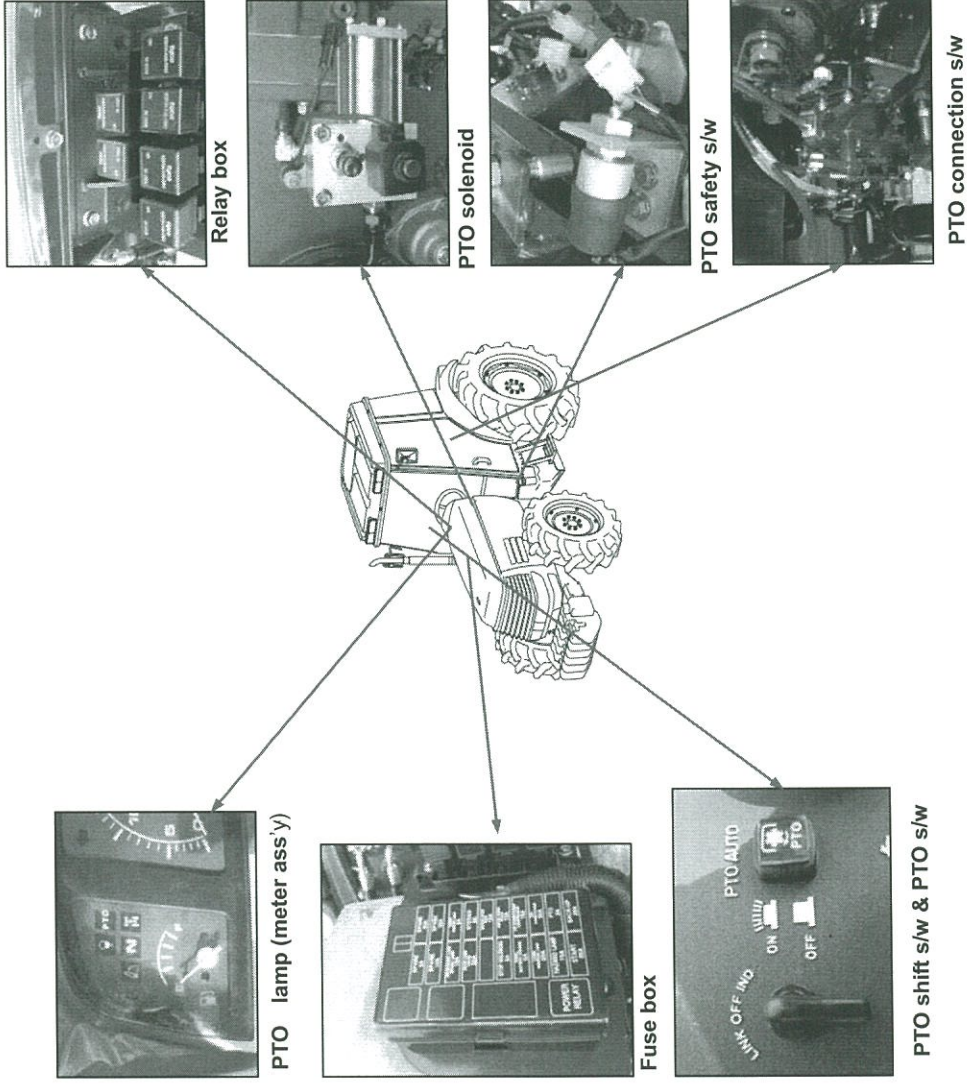

Section	Part name	Part num	Operation
Engine	Fuse F10 [5A]		PTO solenoid valve power
	PTO relay [relay 5P]		PTO solenoid valve operation
Front column	PTO lamp [Meter ass'y]	FBD4190200A9	Indicates PTO operation
	PTO Lamp switch	NTC5410000A4	Connects PTO when lift raise
	PTO shift switch	FTC5180000A3	PTO [ IND, LINK, OFF ] shift switch
	PTO safety switch	FTC5140000A3	Secures safety when start
	PTO solenoid	FT48030000A2	PTO solenoid
Mission	PTO connection s/w	FTC5110000A3	Disconnects PTO when lift arm raises

3. Trouble shooting

PTO lamp does not come on, does not operate PTO (Key switch [On], PTO shift switch [IND], lamp switch [on])	PTO lamp does not come on (Key switch [On], PTO shift switch [IND], lamp switch [on])		PTO does not operate (PTO lamp [On])		PTO disengages with depressing clutch (Key switch [On], PTO shift switch [link], lamp switch [Off], PTO safety switch [On])		PT disengages [Lift raise] (Key switch [On], PTO shift switch [IND, LINK], lamp switch [Off])		PTO disengages [lift switch on] (Key switch [On], PTO shift switch [IND, LINK], lift raise)									
											PTO relay	<input type="checkbox"/>	<input type="checkbox"/>	<input type="checkbox"/>	<input type="checkbox"/>	<input type="checkbox"/>	<input type="checkbox"/>	<input type="checkbox"/>
											PTO shift switch	<input type="checkbox"/>	<input type="checkbox"/>	<input type="checkbox"/>	<input type="checkbox"/>	<input type="checkbox"/>	<input type="checkbox"/>	<input type="checkbox"/>
											PTO safety switch	<input type="checkbox"/>	<input type="checkbox"/>	<input type="checkbox"/>	<input checked="" type="checkbox"/>	<input type="checkbox"/>	<input type="checkbox"/>	<input type="checkbox"/>
											PTO lamp	<input type="checkbox"/>	<input checked="" type="checkbox"/>	<input type="checkbox"/>	<input type="checkbox"/>	<input type="checkbox"/>	<input type="checkbox"/>	<input type="checkbox"/>
Lamp switch	<input type="checkbox"/>	<input type="checkbox"/>	<input checked="" type="checkbox"/>	<input type="checkbox"/>	<input type="checkbox"/>	<input type="checkbox"/>	<input checked="" type="checkbox"/>											
PTO solenoid	<input type="checkbox"/>	<input type="checkbox"/>	<input type="checkbox"/>	<input type="checkbox"/>	<input type="checkbox"/>	<input type="checkbox"/>	<input type="checkbox"/>											
PTO Connection switch	<input type="checkbox"/>	<input type="checkbox"/>	<input type="checkbox"/>	<input checked="" type="checkbox"/>	<input type="checkbox"/>	<input type="checkbox"/>	<input type="checkbox"/>											
Fuse F10	<input checked="" type="checkbox"/>	<input type="checkbox"/>	<input type="checkbox"/>	<input type="checkbox"/>	<input type="checkbox"/>	<input type="checkbox"/>	<input type="checkbox"/>											

#### 4. Electric parts inspection

■ **Fuse box**

Reference 7-8 page

■ **PTO relay**

Reference 7-8 page

■ **PTO lamp on instrument panel**

Reference 7-21 page

■ **PTO shift switch**

Measurement A connector

	Connection		Status	Result
	+	-		
Resist	1	2	IND	0 Ω
	1	3	OFF	
	1	4	LINK	

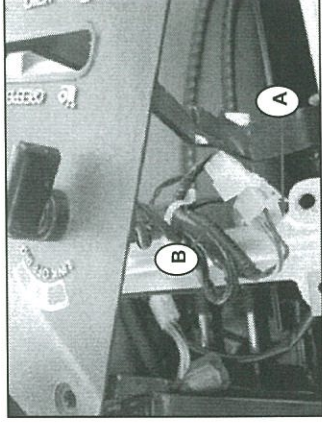

A) A connector B) B connector

Measurement B connector

	Connection		Status	Result
	+	-		
DC power	5	Chassis ground	Key switch [On]	12V
	6	Chassis ground	PTO safety switch [On]	0 Ω
Resist	7			

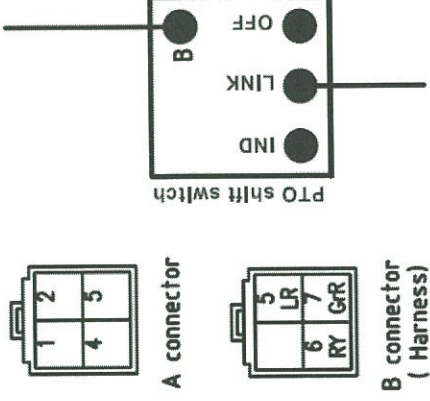

▣ PTO safety switch

Measurement A connector

	Connection		Status	Result
	+	-		
Resist	1	2	Connect	0 Ω

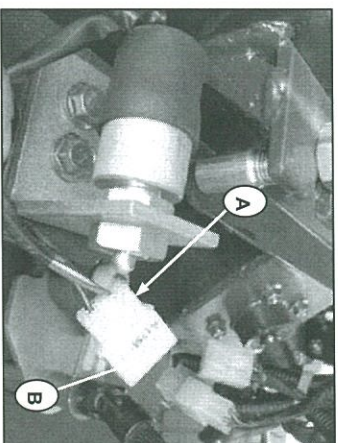

A) A connector B) B connector

Measurement B connector

	Connection		Status	Result
	+	-		
DC power	3	Chassis ground	Key switch [on] PTO shift switch [link]	12V
Resist	4			0 Ω

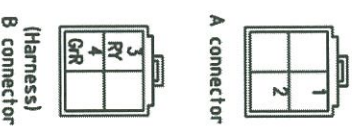

(Harnesse)  
B connector

▣ PTO solenoid valve

Measurement A connector

	Connection		Status	Result
	+	-		
Resist	1	2		Few Ω

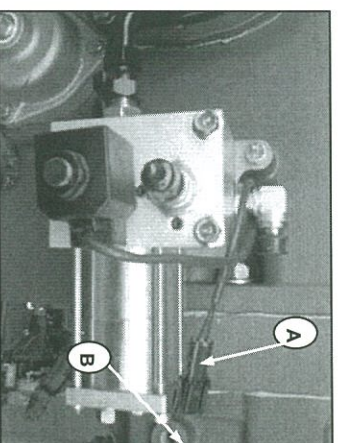

A) A connector B) B connector

Measurement B connector

	Connection		Status	Result
	+	-		
DC power	3	Chassis ground	Key switch [On] PTO shift switch [IND]	12V
Resist	4			0 Ω

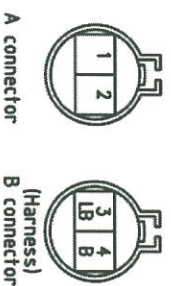

A connector

(Harnesse)  
B connector

▣ PTO engage switch

Measurement A connector

	Connection		Status	Result
	+	-		
Resist	1	2	Connect	0 Ω

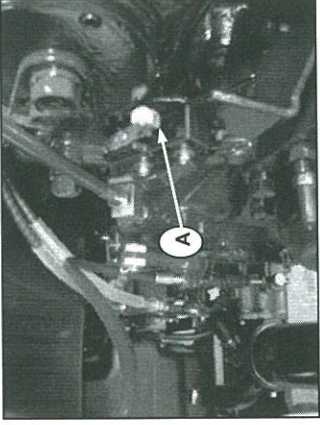

A) PTO engage switch



A connector



B connector  
(Harness)

Measurement B connector

	Connection		Status	Result
	+	-		
DC power	3	Chassis ground	Key switch [on]	12V
	4		PTO shift switch [IND]	
Resist				0 Ω

H. Air - conditioning circuit

1. Diagram

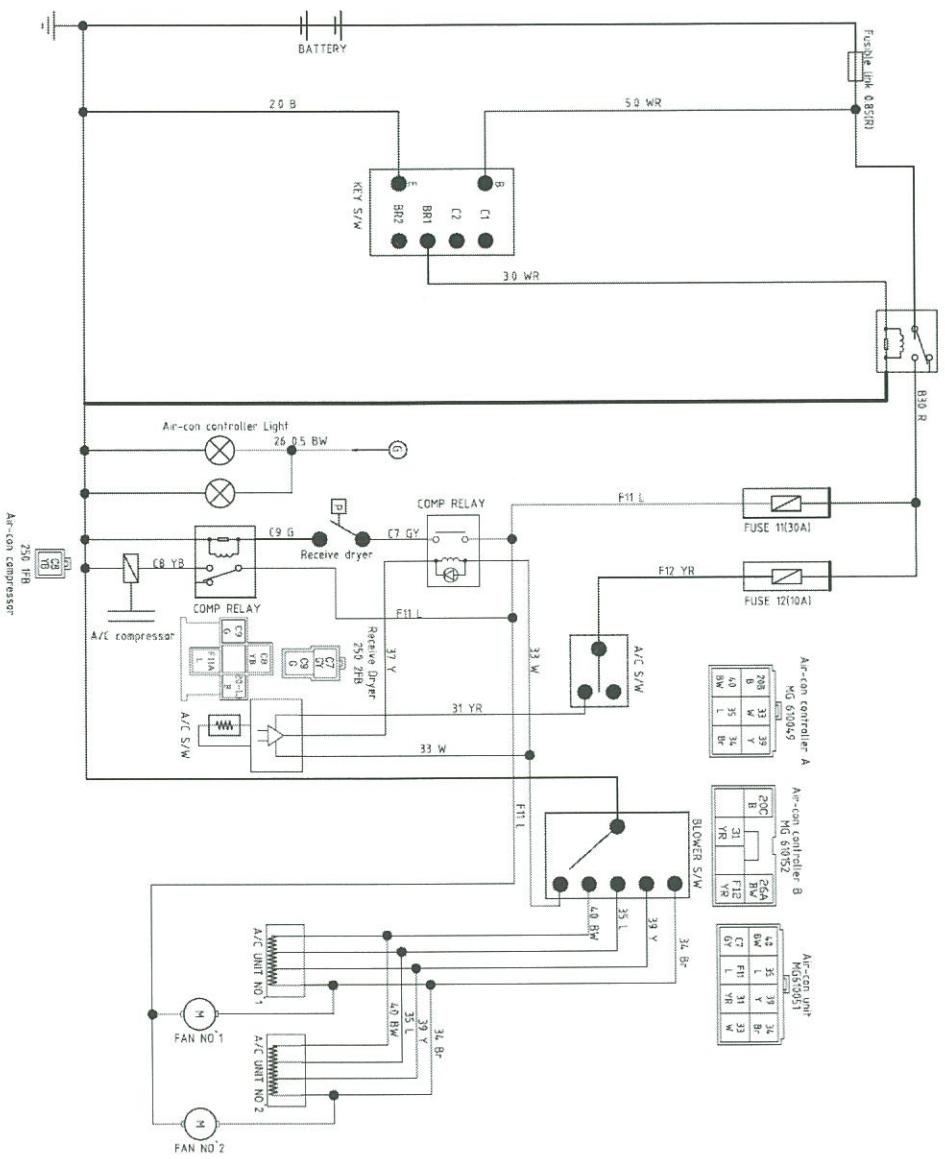

## 2. Component

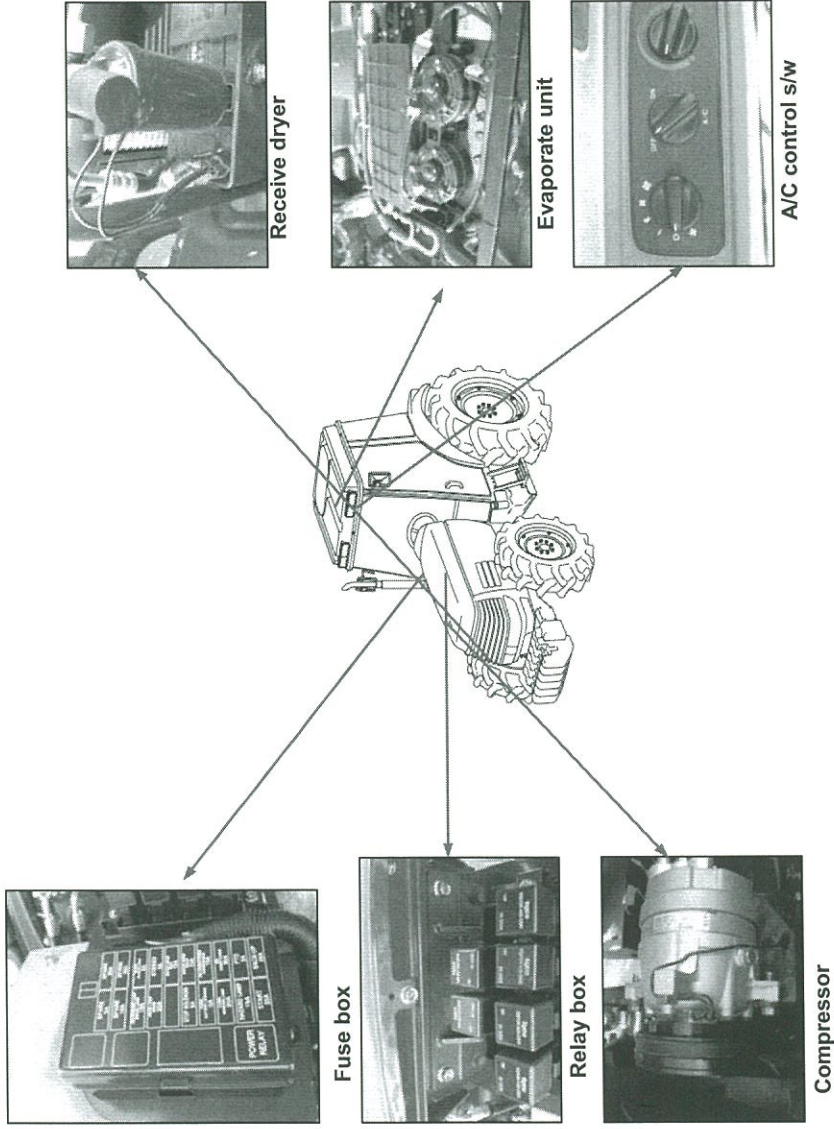

Section	Part name	Part num	Operation
Engine	Fuse F10 [30A]		Air-con power
	Fuse [10A]		Air-con compressor power
	Air-con relay [5P]		Air-con operating relay
	Compressor relay [5P]		Works air-con relay
	Compressor	TTL5020000B2	Controls air-con gas pressure
	Receive dryer	TTL5040000B3	Storage gas
	EVA unit	FBK5010000A0	Controller for air-con wind flow
	Air-con controller s/w	TTL5510000A9	Blower s/w
	Air-con s/w	TTL5510000A9	Air-con on/off
Cabin			

3. Trouble shooting

	Does not operate Eva-unit (Air-con unit Green lamp on)			
	Does not operate Eva-unit (Air-con unit Green lamp off)		Does not operate Air compressor (Air-con unit Green lamp on)	
	Does not operate Air compressor (Air-con unit Green lamp on)		Does not operate Eva-unit at 1 <sup>st</sup> , 2 <sup>nd</sup> grade, only works at 3 <sup>rd</sup> grade (Air-con unit Green lamp on)	
	<input type="radio"/>	<input type="radio"/>	<input type="radio"/>	<input type="radio"/>
	<input type="radio"/>	<input type="radio"/>	<input type="radio"/>	<input type="radio"/>
Air-con controller	<input type="radio"/>	<input type="radio"/>	<input type="radio"/>	<input type="radio"/>
EVA-unit	<input type="radio"/>	<input type="radio"/>	<input type="radio"/>	<input type="radio"/>
Receive dryer	<input type="radio"/>	<input type="radio"/>	<input type="radio"/>	<input type="radio"/>
Air-con compressor	<input type="radio"/>	<input type="radio"/>	<input type="radio"/>	<input type="radio"/>
Fuse F11 [30A]	<input type="radio"/>	<input type="radio"/>	<input type="radio"/>	<input type="radio"/>
Fuse F12 [10A]	<input type="radio"/>	<input type="radio"/>	<input type="radio"/>	<input type="radio"/>
Air-con relay	<input type="radio"/>	<input type="radio"/>	<input type="radio"/>	<input type="radio"/>
Compressor relay	<input type="radio"/>	<input type="radio"/>	<input type="radio"/>	<input type="radio"/>
Heater switch	<input type="radio"/>	<input type="radio"/>	<input type="radio"/>	<input type="radio"/>

# I. Wiper circuit

## 1. Diagram

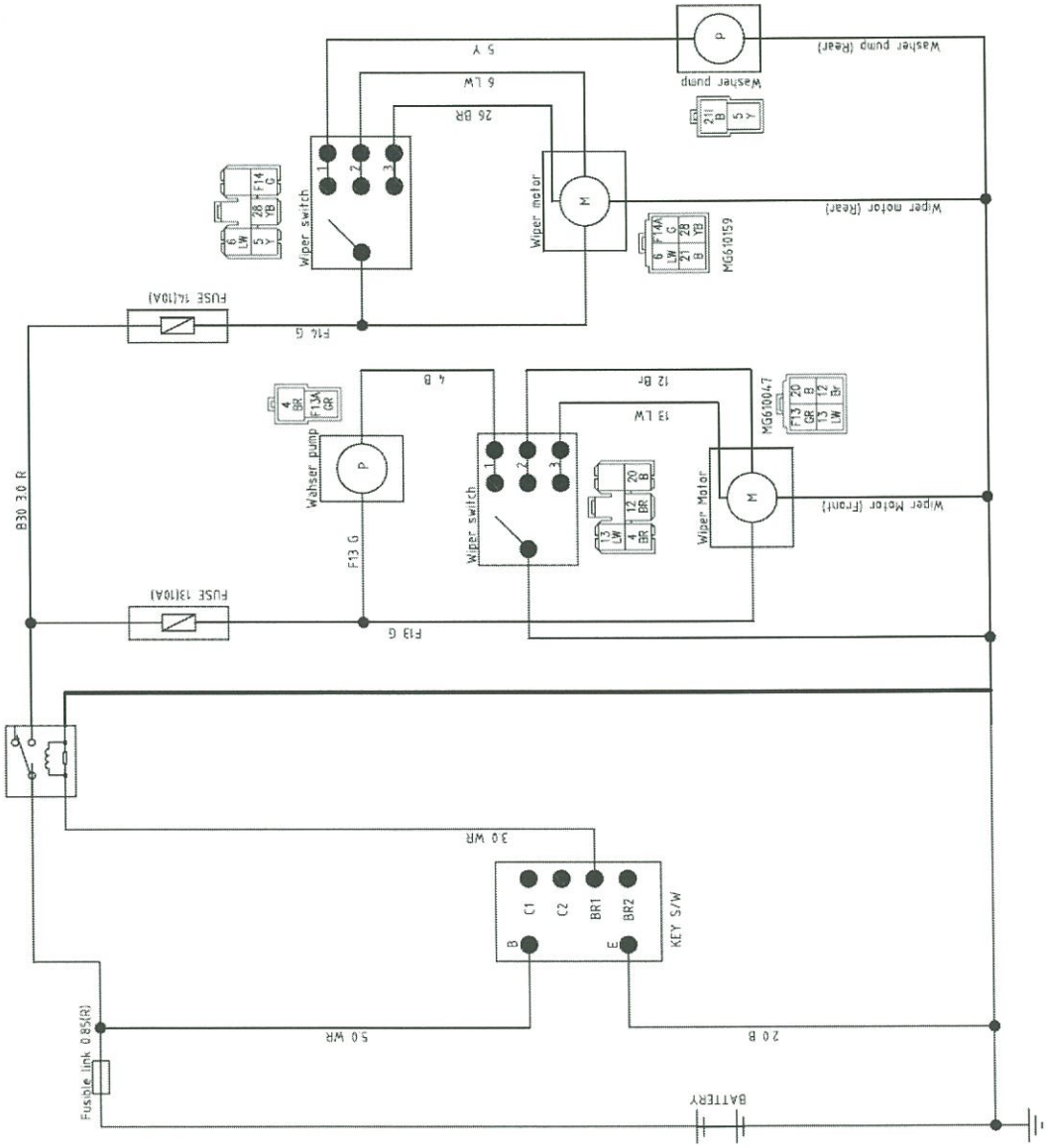

2. Component

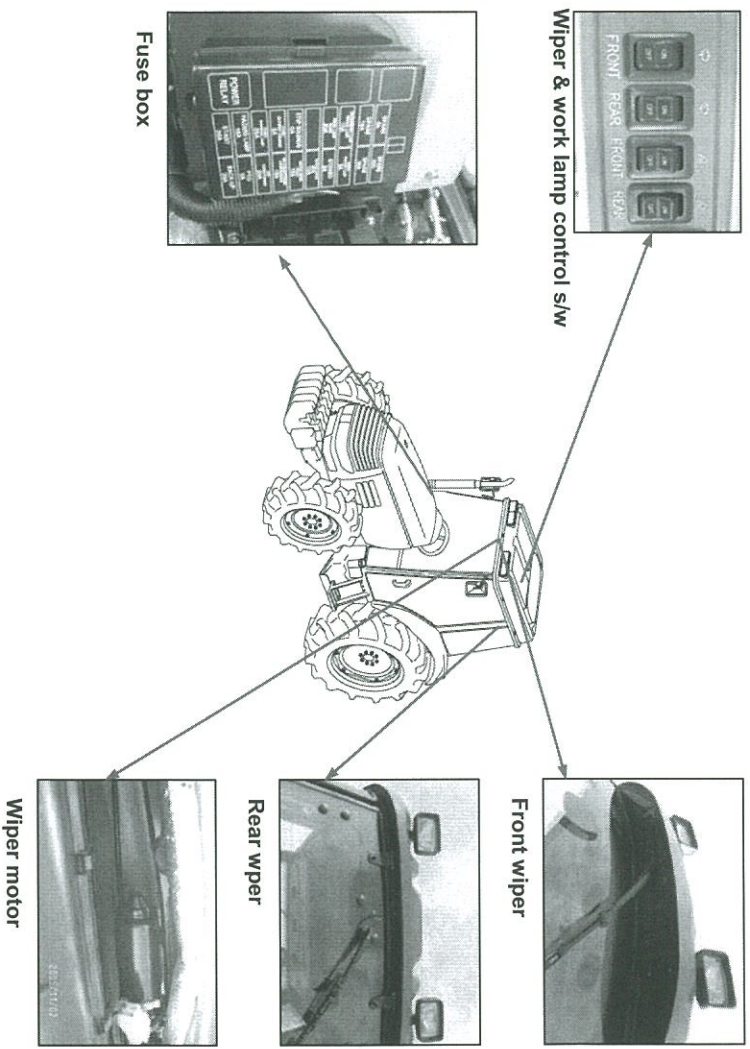

Section	Part name	Part num	Operation
Engine	Fuse F-13 [10A]		Connects power [front]
	Fuse F-14 [10A]		Connects power [rear]
	Wiper switch [front]	THA4309000A9	Works front wiper
Front column	Wiper switch [rear]	THA4309000A9	Works rear wiper
	Wiper motor [front]	TTK6120000A9	Drives front wiper motor
	Wiper motor [rear]	FTK269000A9	Drives rear wiper motor
	Washer pump [front]	DB18280000A4	Front washer pump
Mission	Washer pump [rear]	DB18280000A4	Rear washer pump

### 3. Trouble shooting

	Wiper motor does not operate (Key switch [On], wiper switch [On])	
	Wiper motor does not operate (Washer pump operate)	
	Wiper motor does not operate (Washer motor operate)	
Wiper motor [front]	<input type="radio"/>	<input type="radio"/>
Wiper motor [rear]	<input type="radio"/>	<input type="radio"/>
Wiper pump [front]	<input type="radio"/>	<input checked="" type="radio"/>
Wiper pump [rear]	<input type="radio"/>	<input checked="" type="radio"/>
Wiper switch [front]	<input checked="" type="radio"/>	<input type="radio"/>
Wiper switch [rear]	<input checked="" type="radio"/>	<input type="radio"/>
Fuse F13 [10A]	<input checked="" type="radio"/>	<input type="radio"/>
Fuse F14 [10A]	<input checked="" type="radio"/>	<input type="radio"/>

4. Electric parts inspection

Fuse box

Reference 7-8 page

Wiper switch

Measurement A connector

Resist	Connection		Status	Result
	+	-		
0 Ω	2	5	Press switch	
	3	4		Switch on

Measurement B connector [front wiper switch]

DC power	Connection		Status	Result
	+	-		
12 V	6	Chassis ground	Starter switch [On]	
	9			
	Resist	8	10	0 Ω

Measurement B connector [rear wiper switch]

DC power	Connection		Status	Result
	+	-		
12 V	6	Chassis ground	Starter switch [On]	
	9	ground		

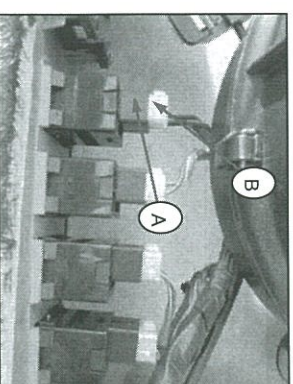

A) A connector B) B connector

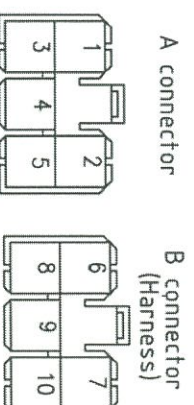

■ Wiper motor [front]

Measurement B connector

	Connection		Status	Result
	+	-		
DC power	2	1		0 Ω
	3	1		
	4	1		

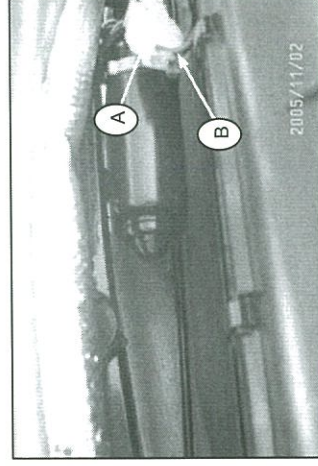

A) A connector B) B connector

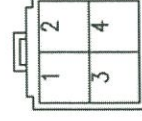

A connector

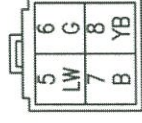

B connector (Harness)

Measurement B connector

	Connection		Status	Result
	+	-		
DC power	5	6	Starter switch [On]	12 V
	9	6	Starter switch [On] Wiper switch [On]	0 Ω
	7	6	Key switch [On] Wiper switch [press]	0 Ω
Resist	6	Chassis ground		0 Ω

■ Wiper motor [rear]

Measurement A connector

	Connection		Status	Result
	+	-		
Resist	1	4		0 Ω
	2	4		
	3	4		

Measurement B connector [chassis]

	Connection		Status	Result
	+	-		
DC power	8	7	Starter switch [On]	12 V
	6	7	Starter switch [On] Wiper switch [On]	
	5	7	Key switch [On] Wiper switch [press]	
Resist	6	Chassis ground		0 Ω

Washer pump

Measurement A connector

	Connection		Status	Result
	+	-		
Resist	1	2		Few $\Omega$

A connector      B connector

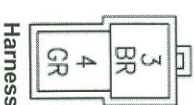
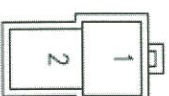

Measurement B connector [Harness]

	Connection		Status	Result
	+	-		
DC power	3	4	Starter switch [On] Wiper switch [press]	12 V



2. Components

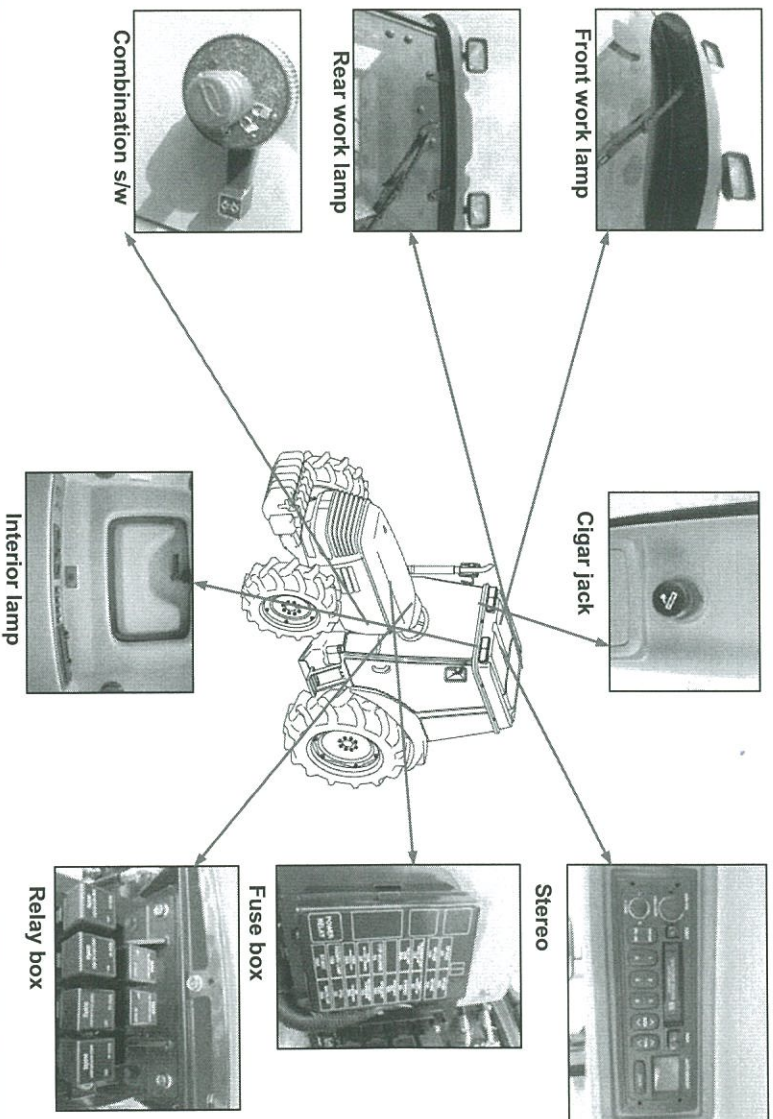

Section	Part name	Part num	Operation
	Fuse F03 [20A]		Supplies power work lamp
	Fuse F07 [20A]		Supplies power headlamp
	Work lamp relay R3 [Relay 5P]		Works lamp relay [front]
	Work lamp relay R6 [Relay 5P]		Works lamp relay [rear]
Engine	Work lamp switch [front]	THA4324000A9	Works lamp switch [front]
	Work lamp switch [rear]	THA4324000A9	Works lamp switch [rear]
	Work lamp [front]	FBK4030000B3	Works lamp [front]
	Work lamp [rear]	FBK4030000B3	Works lamp [rear]
	Combination switch	CBF3010000A2	Works head lamp
	Stereo	CJP5140000A3	Stereo
	Speaker	DB18270000A3	Stereo speaker
Cabin	Interior lamp	THA4213000A9	Cabin interior lamp

### 3. Trouble shooting

	Light does not on work lamp-head lamp on (Key switch [On], lamp switch [On], work lamp switch [On])										
	Light does not light on work lamp-head lamp off (Key switch [On], lamp switch [On], work lamp switch [On])										
	Light does not on work lamp-only inside head lamp on (Key switch [On], lamp switch [On, work lamp switch [On]])										
	Interior lamp does not work (Interior lamp switch [On])										
	Car-stereo does not work (key switch [On])										
	Car-stereo does not store memory and not light on interior lamp (Key switch [ON])										
	Car-stereo does not work and no sound (Key switch [On])										
	Cabin work lamp [front]	⊙									
	Cabin work lamp [rear]	⊙									
	Work lamp switch [front]										
Work lamp switch [rear]											
Work lamp relay [front]	⊙										
Work lamp relay [rear]	⊙										
Fuse F3 [20A]	⊙										
Fuse F7 [20A]		⊙									
Combination switch		⊙									
Interior lamp			⊙								
Car stereo				⊙					⊙		
Speaker									⊙		
Cigar jack											
Fuse F11 [30A]											
Fuse F15 [5 A]								⊙			
Fuse F16 [5 A]					⊙				⊙	⊙	