

5.2.11 FR SWITCH

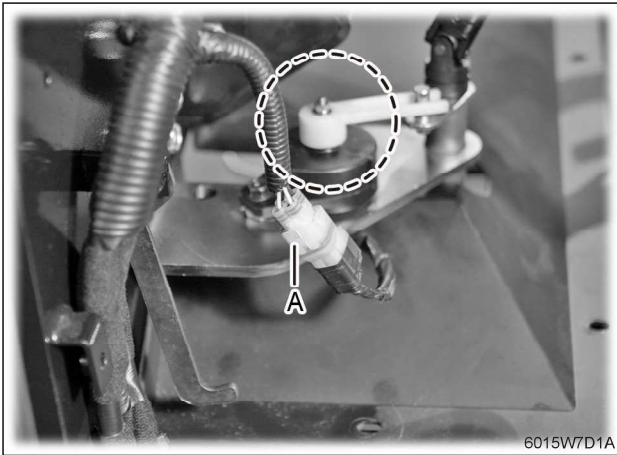

6015W7D1A

The FR switch is installed under the shuttle shift lever on the dashboard.

This switch sends a signal to the instrument cluster according to the position of the shuttle shift lever to turn on the F, R or N lamp.

► CONNECTOR TEST

1	2
Lg	LgW
3	4
B	B

ITEM	CONNECTION		STATUS	RESULT
	+	-		
Resistance	1	3	Shuttle shift leverNeutral	0 Ω

6015W7C9A

5.2.12 BRAKE (ONE SIDE) SWITCH

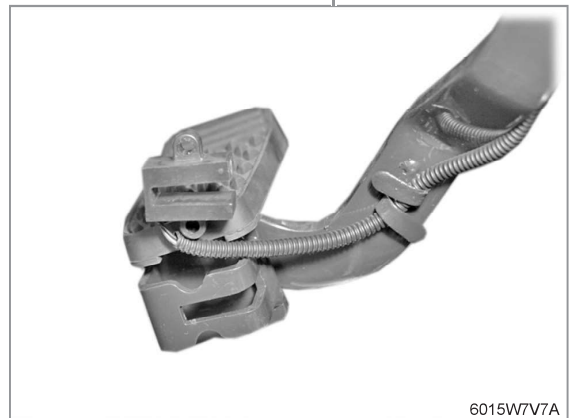
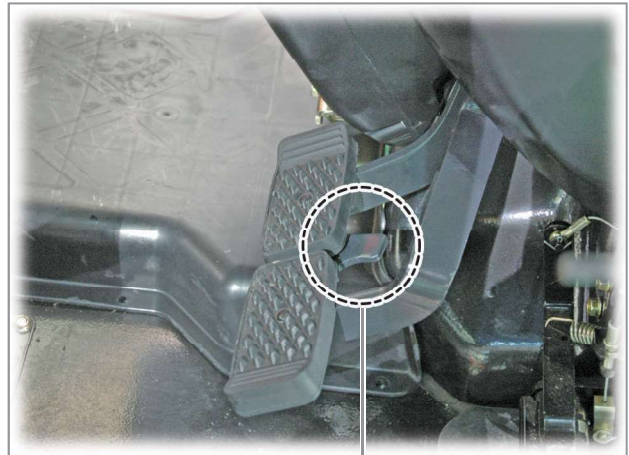

6015W7V7A

K20W7A05A

The brake (one side) switch is installed on the side of the connecting lever between the brake pedals.

When disengaging the lever, the switch contact is connected to send a signal to the instrument cluster.

► CONNECTOR (WIRING SHAFT) TEST

1	2
B	LR

ITEM	CONNECTION		STATUS	RESULT
	+	-		
Resistance	2	1	Brake pedal lever connected	$\infty \Omega$
			Brake pedal lever disengaged (one-side brake statue)	0 Ω

6015W7C7A

5.2.13 STARTER

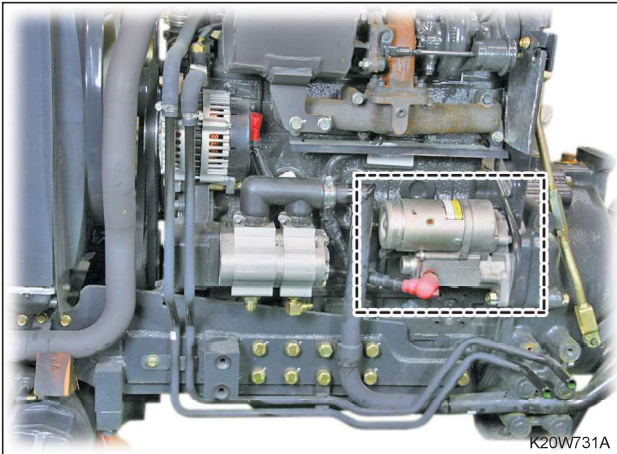

The starter is installed to the rear left section of the engine.

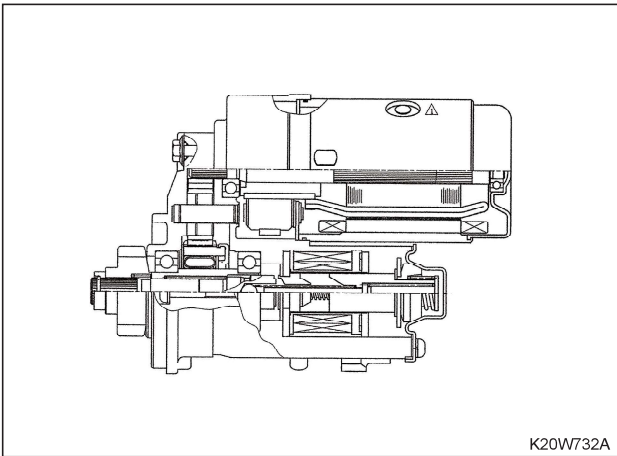

► CIRCUIT DIAGRAM

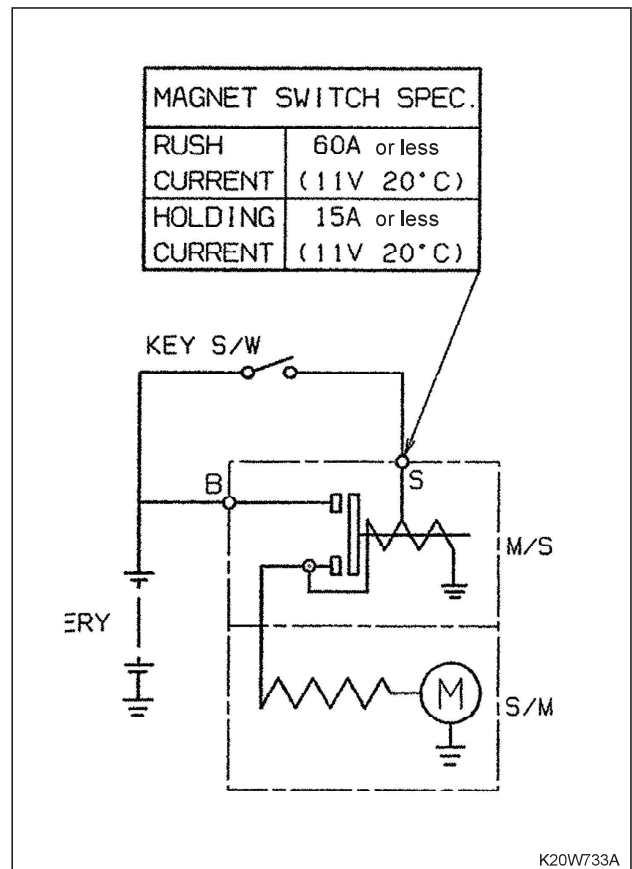

K20W733A

► SPECIFICATION

NOMINAL POWER	2.0 kw
VOLTAGE	12 V
RATED TIME	30 sec.
ROTATION	Clockwise (when seeing from pinion side)
WEIGHT	Approx. 5.2 kg

5.2.14 ALTERNATOR

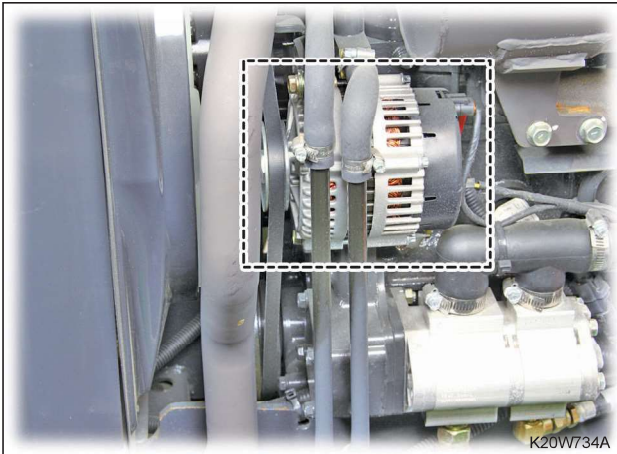

The alternator is installed in the left front section of the engine and it is integrated with the IC regulator.

It supplies power to components with high electric load and charges the battery.

► CONNECTOR TEST

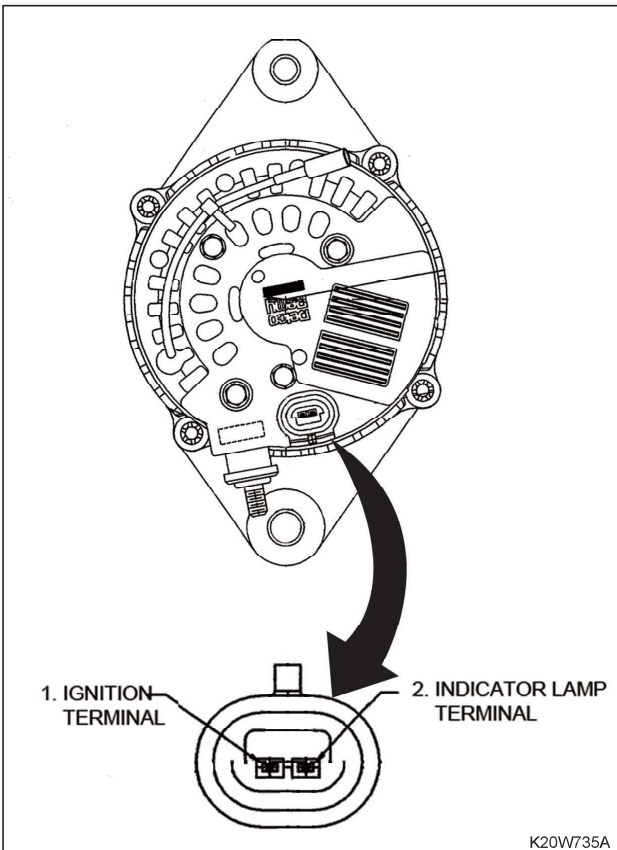

ITEM	CONNECTION		STATUS	RESULT
	+	-		
CONNECTOR DC POWER	1	Ground (Chassis)	Ignition switch ON	Approx. 12 V
	2	Ground (Chassis)		

5.2.15 ENGINE OIL PRESSURE SWITCH

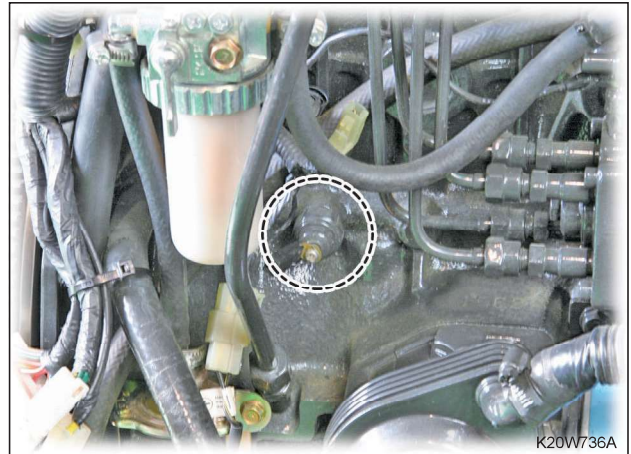

The engine oil pressure switch is installed to the cylinder block on the right side of the engine. When pressure is built in the engine, the contact of the oil pressure switch is connected to send a signal to the instrument cluster assembly.

When the pressure in the engine drops below  $0.5 \pm 0.1 \text{ kgf/cm}^2$ , the engine oil pressure warning lamp on the instrument cluster comes on.

► CONNECTOR TEST

ITEM	CONNECTION		STATUS	RESULT
	+	-		
Resistance	A	Ground (Chassis)	Engine stopped	$0 \Omega$
			Engine running	$\infty \Omega$
DC power	B	Ground (Chassis)	Oil pressure warning lamp 「ON」 Ignition switch 「ON」	12 V

5.2.16 COOLANT TEMPERATURE SENSOR (PREHEATING)

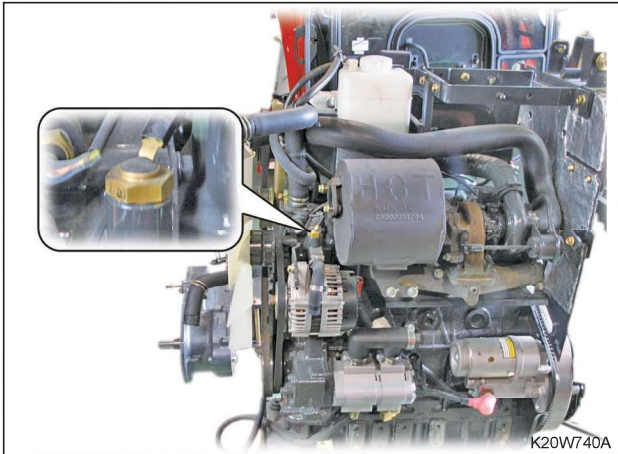

The coolant temperature sensor (preheating) is installed to the coolant flange behind the cooling fan. It sends various resistance values according to the coolant temperature to the instrument cluster to display the coolant temperature on the coolant gauge.

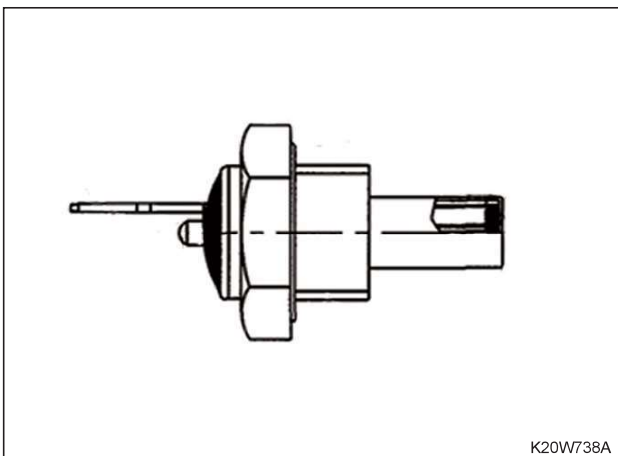

► RESISTANCE BY COOLANT TEMPERATURE

TEMPERATURE (°C)	-30	-15	10	20	40
RESISTANCE DIFFERENCE (Ω)	19.5	9.6	3.4	2.4	1.2

► MEASURING CIRCUIT

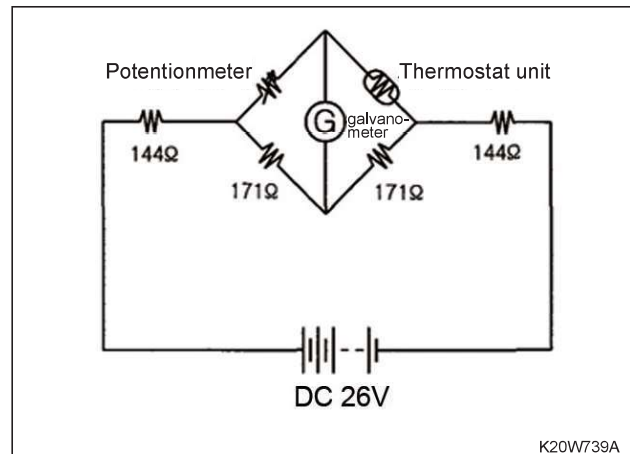

► SENSOR TEST

ITEM	CONNECTION		STATUS	RESULT
	+	-		
Resistance	1	Ground (Chassis)	-	Resistance changed by coolant temperature
DC power	2	Ground (Chassis)	Ignition switch 「ON」	Approx. 12 V

5.2.17 COOLANT TEMPERATURE SENSOR (METER)

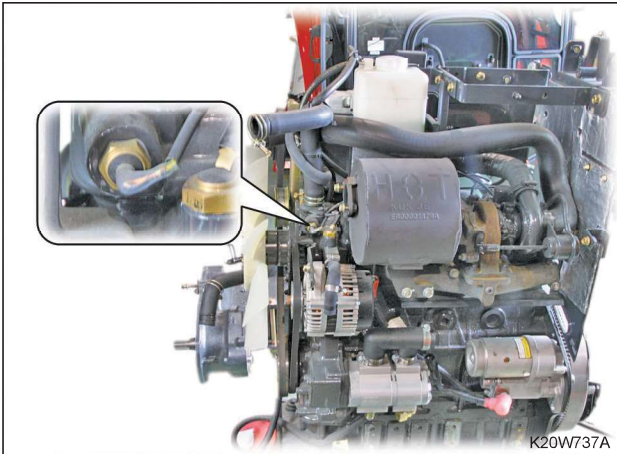

The coolant temperature sensor (meter) is installed to the outlet of the heater hose in front of the coolant flange to supply information to the preheat controller in order to determine the preheat indicator ON time and preheat relay connection time.

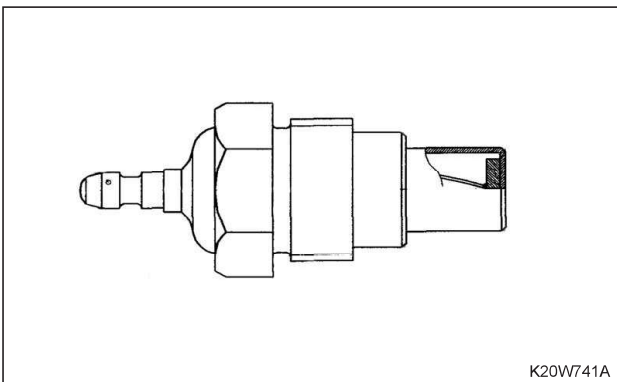

► RESISTANCE BY COOLANT TEMPERATURE

TEMPERATURE (°C)	(35)	(50)	80	(100)	(105)	115	(120)	(140)
RESISTANCE (KΩ)	(670)	(350)	118±6	(63.5)	(54.5)	42±2.5	(36.2)	(22)

► MEASURING CIRCUIT

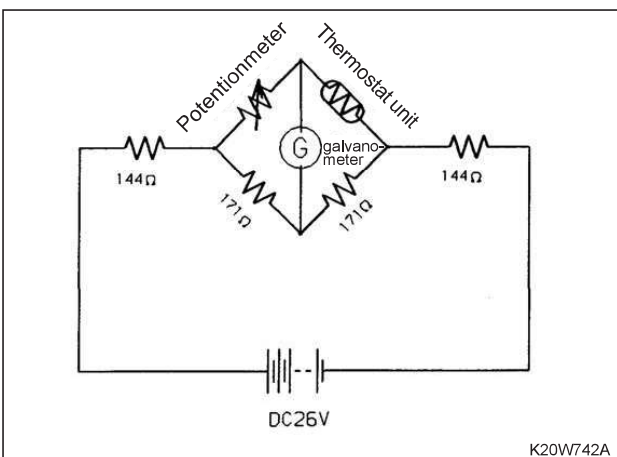

5.2.18 FUEL CUT-OFF SOLENOID

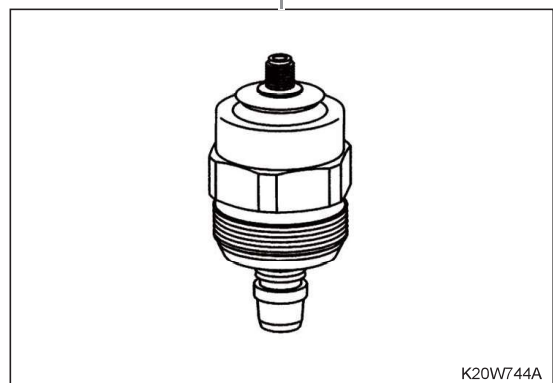
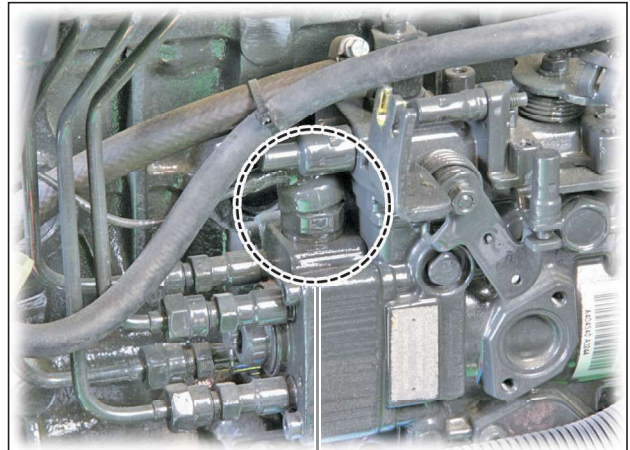

The fuel cut-off solenoid is installed behind the injection pump in the right section of the engine to allow or block fuel entering the engine depending on the position (ON/OFF) of the ignition switch.

► SPECIFICATION

RATED VOLTAGE	12 V
POWER CONSUMPTION	16 W
START VOLTAGE	6.5 V
HOLDING VOLTAGE	2.5 V
OPENING VOLTAGE	0.5 V

5.2.19 FUEL SENSOR

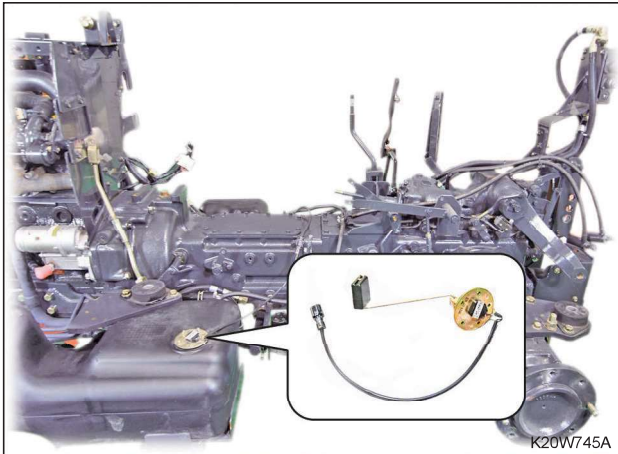

The fuel sensor is installed to the top of the left fuel tank and consists of the float and variable resistor. The float detects the fuel level and the sensor sends the corresponding resistance value to the fuel gauge on the instrument cluster to display the fuel level.

► RESISTANCE BY FLOAT POSITION

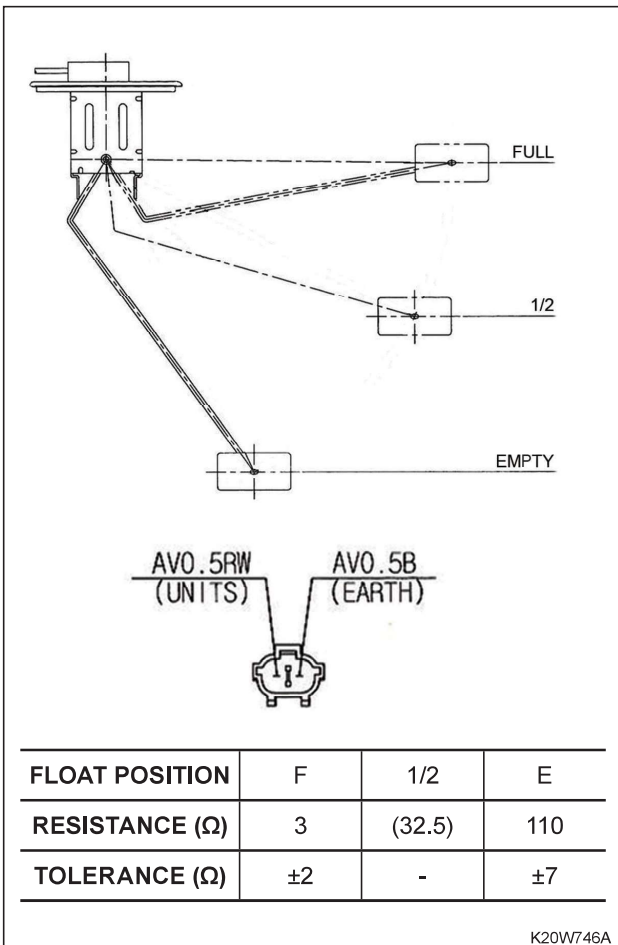

5.2.20 GLOW PLUG

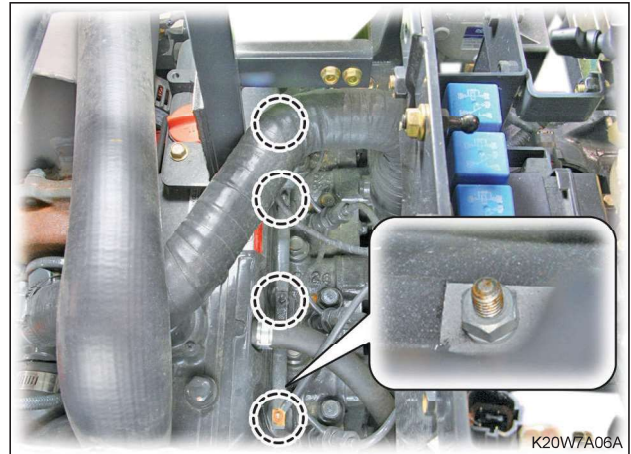

The glow plug is installed to the engine cylinder head to heat the intake air in the pre-combustion chamber in order to facilitate engine starting. The current of the glow plug should be 10 A within 5 seconds after it is applied with DC 11 V and its temperature should rise to 800° in approx. 4.5 seconds.

► FEATURE

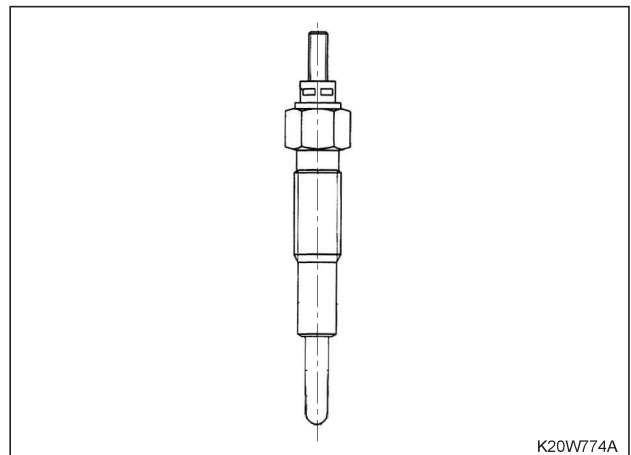

5.2.21 HORN

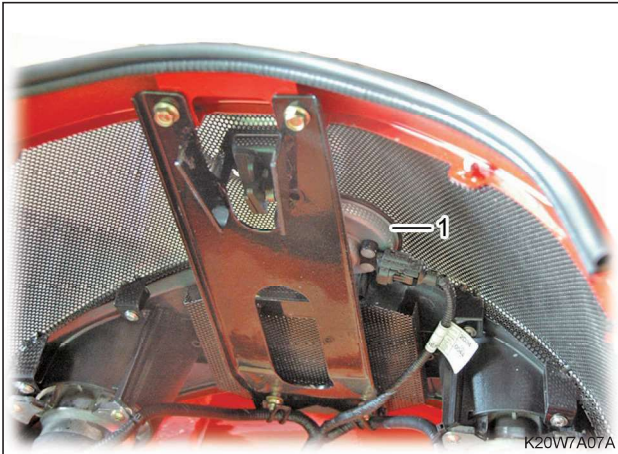

The horn (1) is installed between the left and right headlamps on the front of the hood.

5.2.22 COMBINATION SWITCH



The combination switch is installed to the left side of the dashboard for operation of the headlamp high/low beam, turn signal lamps and horn.

► CONNECTOR TEST

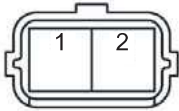
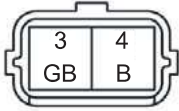
Connector A		6015W7F3A
Connector B		6015W7F4A

ITEM	CONNECTION		STATUS	RESULT
	+	-		
Resistance	2	1	-	Approx. 4.7 Ω
	3	Ground (Chassis)	Ignition switch 「ON」 Horn operated	Approx. 4.7 Ω
	4		-	-

► CONNECTOR AND WIRING DIAGRAM

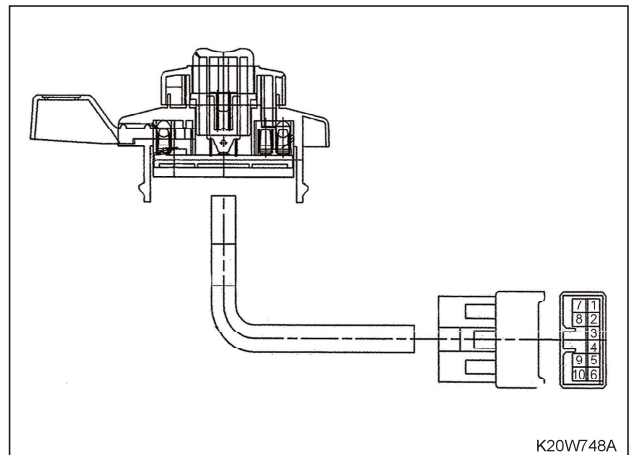

HEADLAMP					TURN SIGNAL LAMP			HORN			
ITEM	B1	T	1	2	ITEM	B2	R	L	ITEM	B3	H
WIRING COLOR	RY	Y	OR	BR	WIRING COLOR	G	RW	GW	WIRING COLOR	8	LW
CIRCUIT NO.	9	5	4	10	CIRCUIT NO.	8	3	2	CIRCUIT NO.	7	1
○					⇒	○	○		FREE		
≡○	○	○	○		OFF				PUSH	○	○
≡○	○	○	○	○	⇐	○	○	○			

5.2.23 TRAILER CONNECTING SOCKET

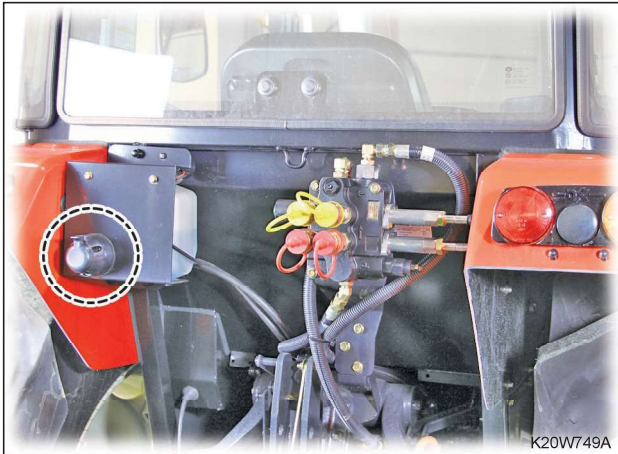

The trailer connecting socket is installed to the washer fluid tank bracket in the back of the tractor. It is connected to an external draft implement to supply power to the implement for illumination of the lamps.

► CONNECTOR AND WIRING TABLE

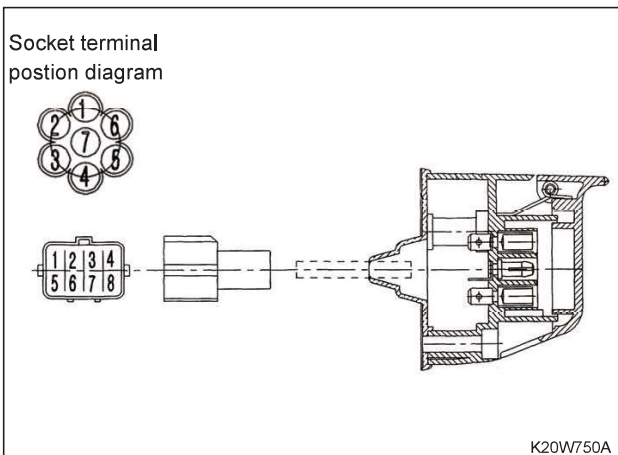

TERMINAL NO.	WIRING SPEC.	COLOR	FUNCTION	HOUSING	REMARKS
1	AVS0.85	GB	Turn signal lamp (LH)	6	
2	AVS0.85	GL	Tail lamp	4	
3	AVS0.85	RB	Turn signal lamp (RH)	7	
4	AVS0.85	WG	Brake lamp	8	
5	AVS0.85	RW	Work lamp	3	Backup lamp
6	AVS0.85	Or	Spare power (+)	2	
7	AVS0.85	B	Ground	1	

5.2.24 HEADLAMP

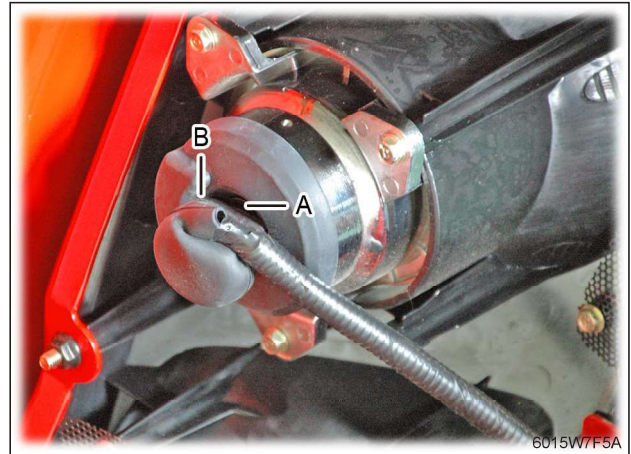

The headlamps are installed to the left and right side on the front of the hood.

► CONNECTOR TEST

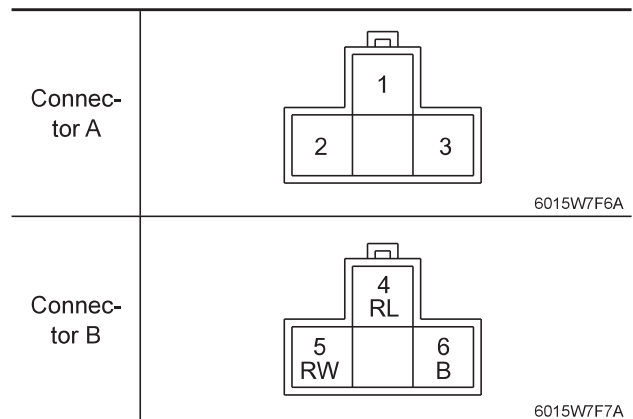

ITEM	CONNECTION		STATUS	RESULT
	+	-		
Resistance	3	2	Headlamp High beam	Little Ω
	1	2	Headlamp Low beam	
	6	(Chassis) Ground	-	0 Ω
DC power	4	(Chassis) Ground	Ignition switch 「ON」 Headlamp low beam	12 V
	5		Ignition switch 「ON」 Headlamp high beam	

5.2.25 INSTRUMENT CLUSTER

► CONFIGURATION AND PERFORMANCE SPECIFICATIONS

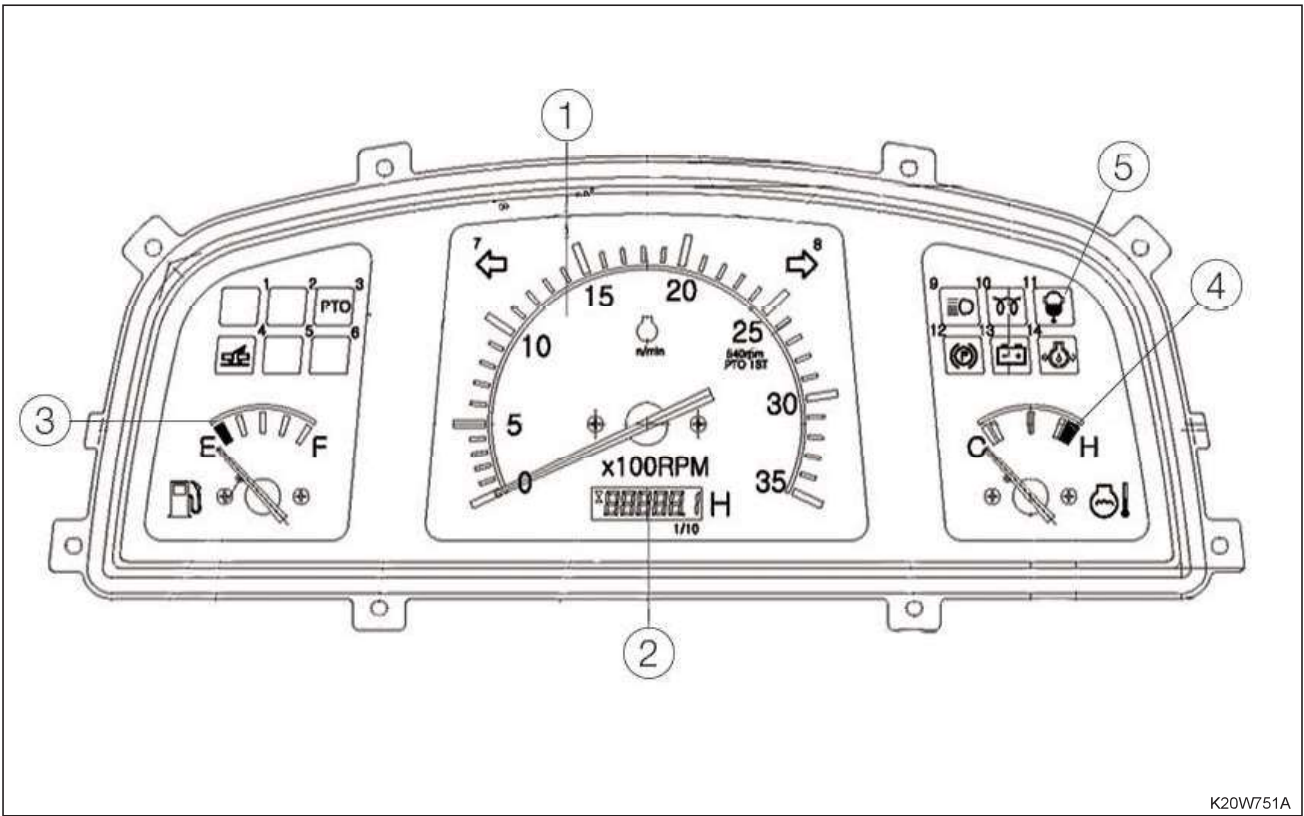

K20W751A

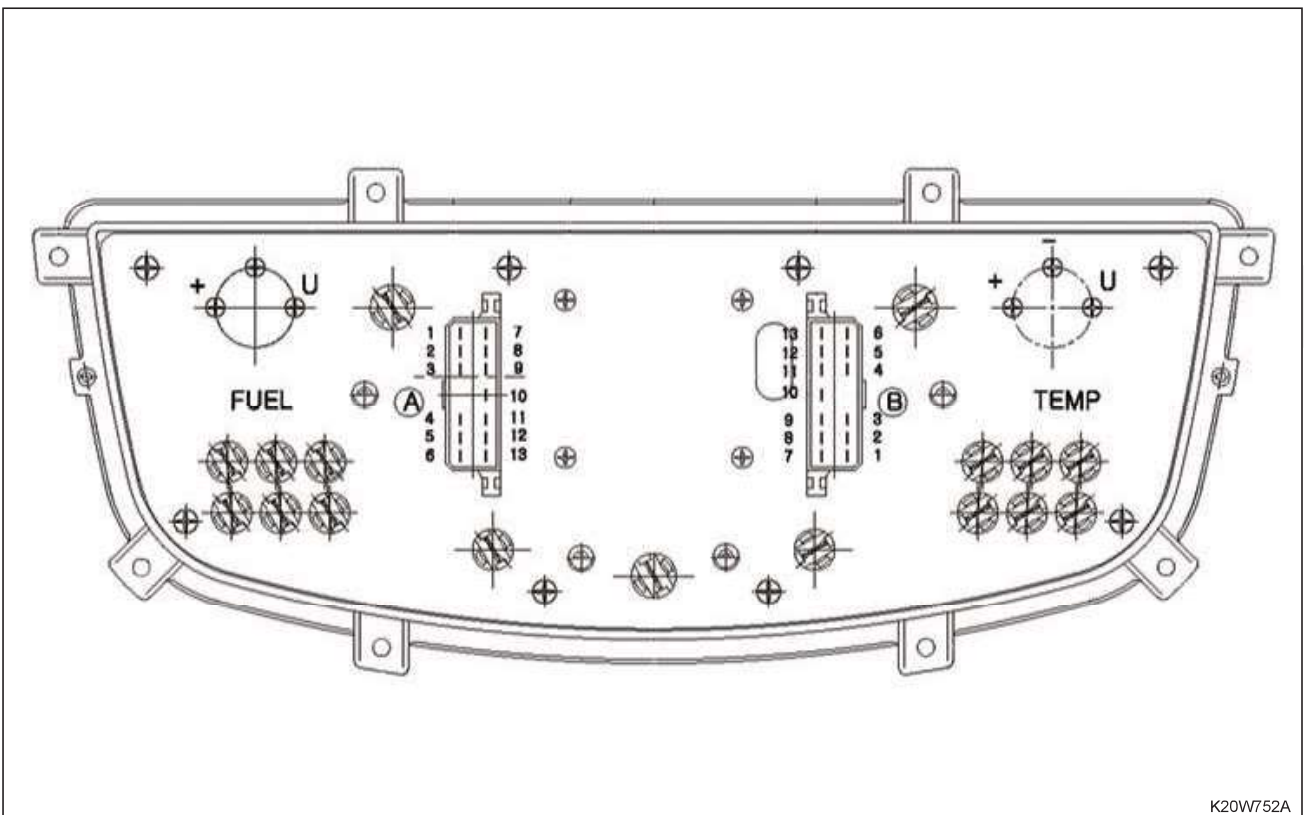

K20W752A

► CONNECTOR AND CIRCUIT

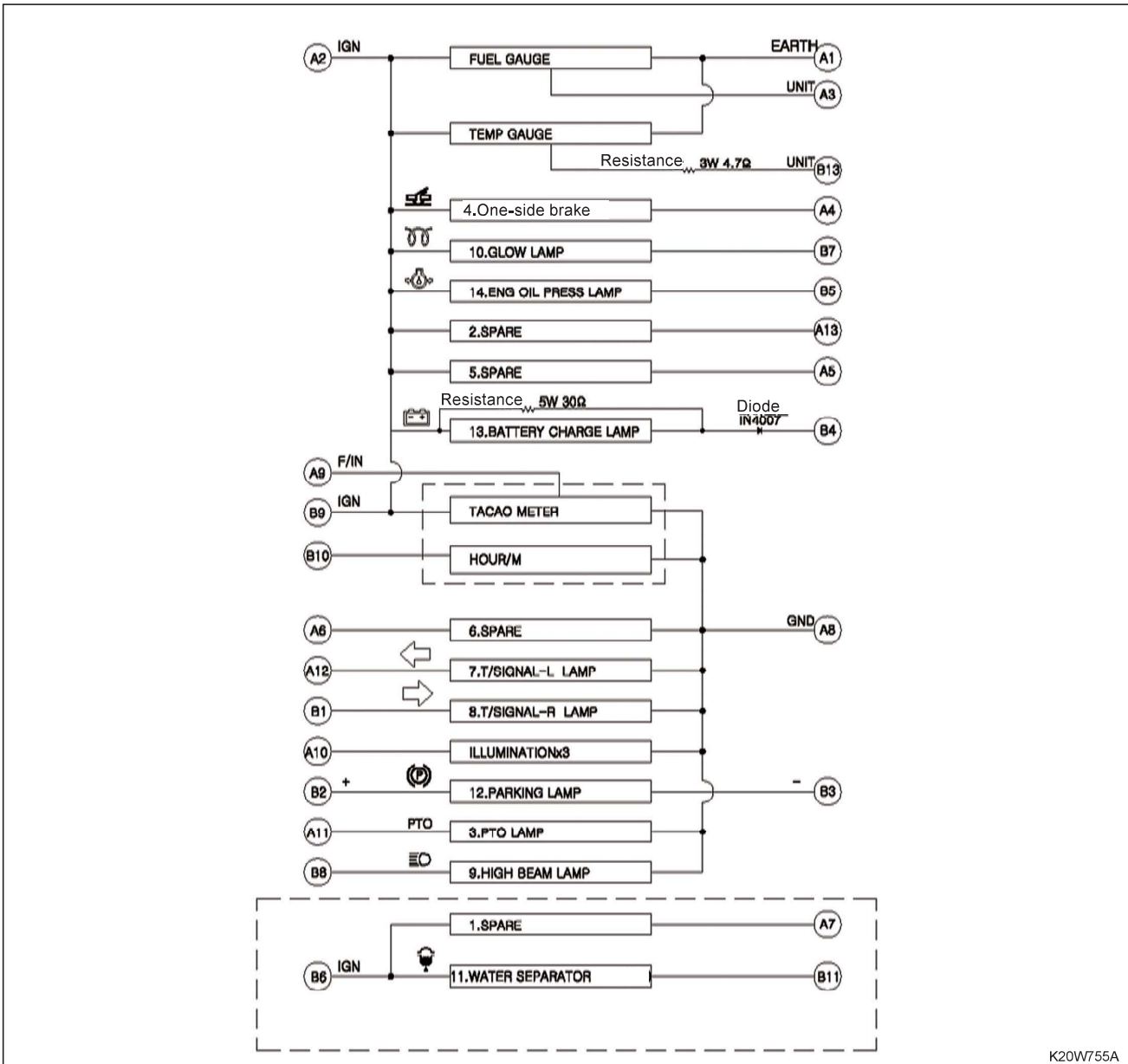
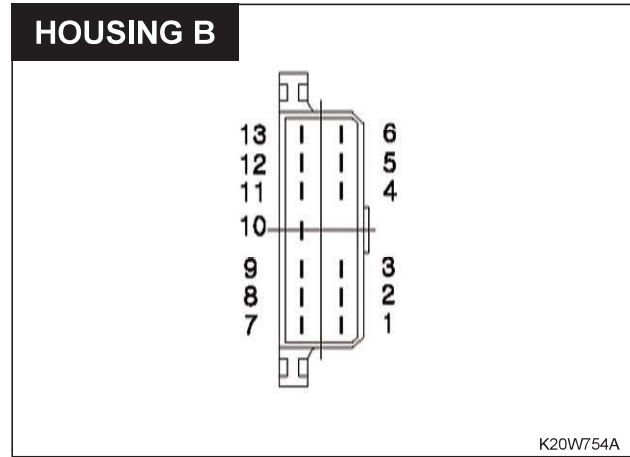
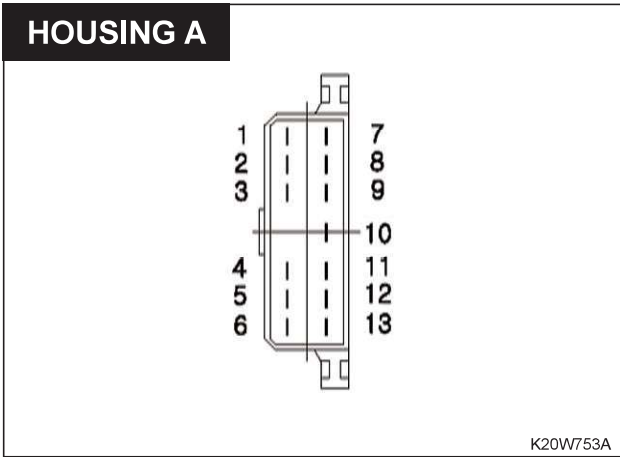

► PERFORMANCE SPECIFICATIONS

1. Tachometer

PTO RPM		PTO 540 rpm → 2,600 rpm			
Operating range		0 - 3,500 rpm			
Indicator characteristics	Position (rpm)	1,000	2,000	2,500	3,000
	Tolerance (rpm)	+ 50 - 150	(± 100)	± 100	(+ 250) 0
	Frequency (Hz)	184.6	(369.2)	461.5	553.8

Zone

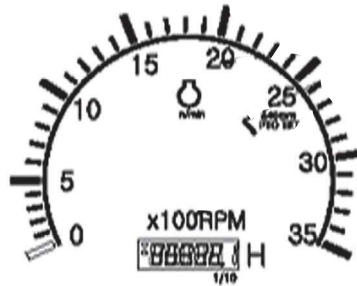

K20W761A

2. Hourmeter

Type	Quartz (LCD type)
Rated voltage	Free voltage (12 / 24 V)
Operational voltage range	DC 10 V - 32 V
Operational temperature range	-20°- +80°
Max. displaying time	99999.9 hours
Time accuracy	± 5 sec./24 hr.(for continuous operation)

Display

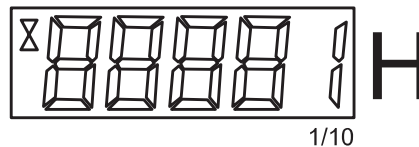

K20W762A

3. Fuel gauge

Type		Moving coil type (MG-3)		
Operational voltage		DC 12 V		
Indicator characteristics	Position	E	1/2	F
	Resistance (Ω)	95	(32.5)	7
	Tolerance (°)	± 3.75	-	± 3.75

Zone



K20W763A

4. Coolant temperature gauge

Type		Moving coil type (MG-3)			
Operational voltage		DC 12 V			
Indicator characteristics	Position	43	90	121	138
	Resistance (Ω)	(400)	89.3	35.2	(13.5)
	Tolerance (°)	-	± 4.8	± 2.5	-
Zone					

K20W763A

5. Indicator

SYMBOL	1 SPARE	2 SPARE	3 PTO	4 	5 SPARE	6 SPARE	7 
COLOR	-	-	RED	-	-	-	GREEN
LAMP	DC 14 V 1.4 W						
SYMBOL	8 	9 	10 	11 	12 	13 	14 
COLOR	GREEN	BLUE	RED	RED	RED	RED	RED
LAMP	DC 14 V 1.4 W						

5.2.26 PARKING BRAKE SWITCH



The parking brake switch is installed in front of the parking brake.

When the parking brake is applied, the switch contact is connected and the parking indicator on the instrument cluster is turned on.

► CONNECTOR

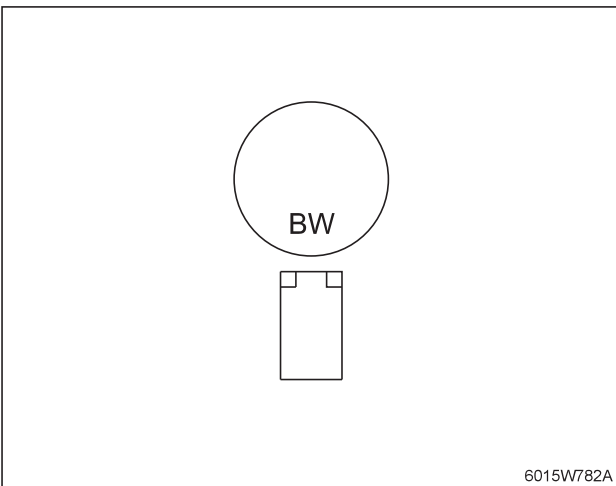

5.2.27 4WD SWITCH

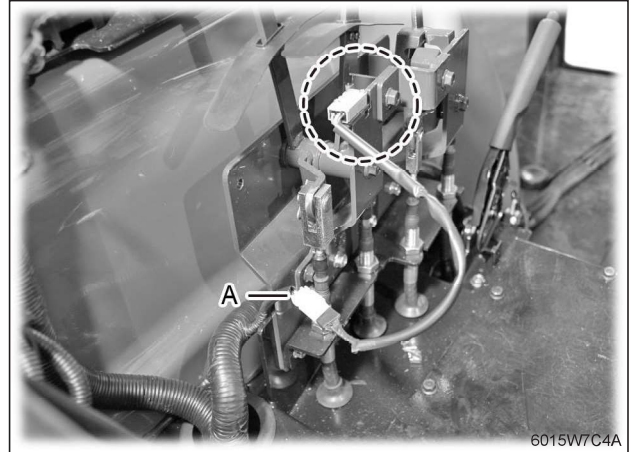

The 4WD switch is installed on the back of the 4WD lever on the left side of the seat.

When pulling the lever to the 4WD position, the switch contact is connected to send a signal to the instrument cluster.

► CONNECTOR A TEST

ITEM	CONNECTION		STATUS	RESULT
	+	-		
Re-sis-tance	1	2	4WD lever 「ON」	0 Ω
			4WD lever 「OFF」	∞Ω

## 5.3 LAMP BULB REPLACEMENT

## 5.3.1 HEADLAMP

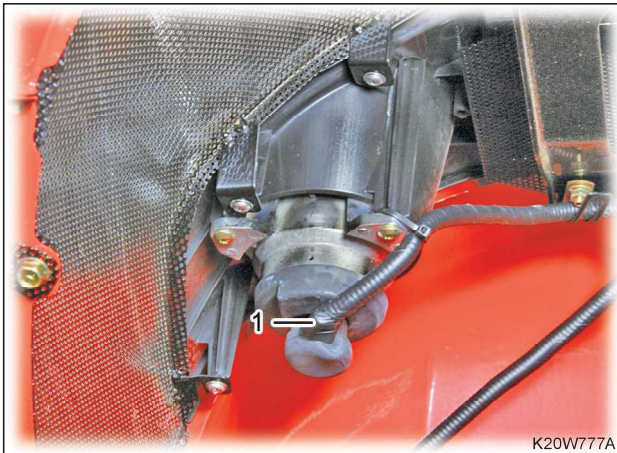

K20W777A

1. Pull the headlamp connector (1) to disconnect it.

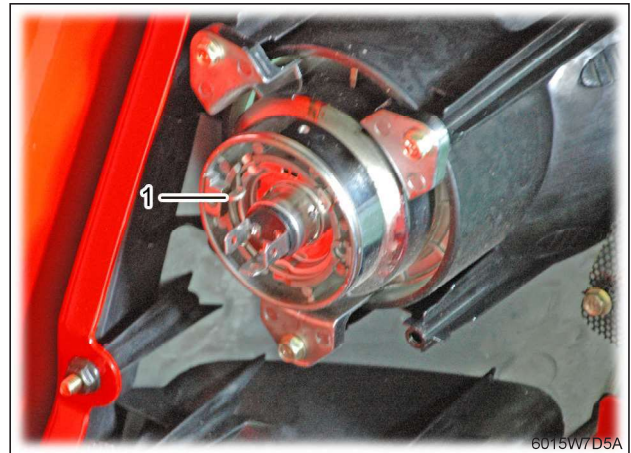

6015W7D5A

4. Fit a new bulb into the groove and fit the spring holder (1). Then, place the rubber cap on it and connect the connector.

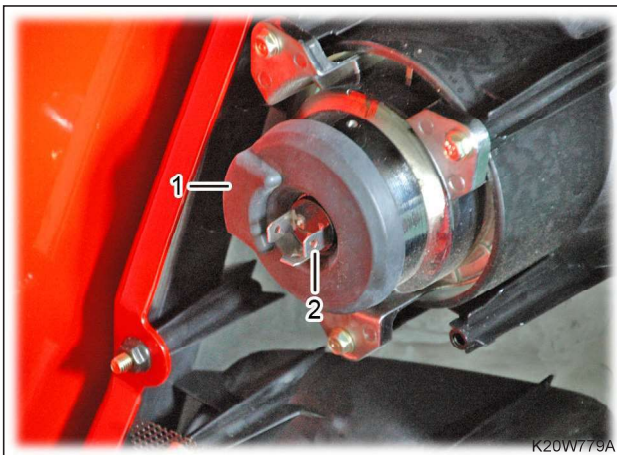

K20W779A

2. Pull out the rubber cap (1) and spring holder and turn the socket (2) to remove it.



6015W7D4A

3. Bulb specification: 12 V 55 W/55 W

5.3.2 FRONT TURN SIGNAL LAMP (US MODEL)



K20W790A

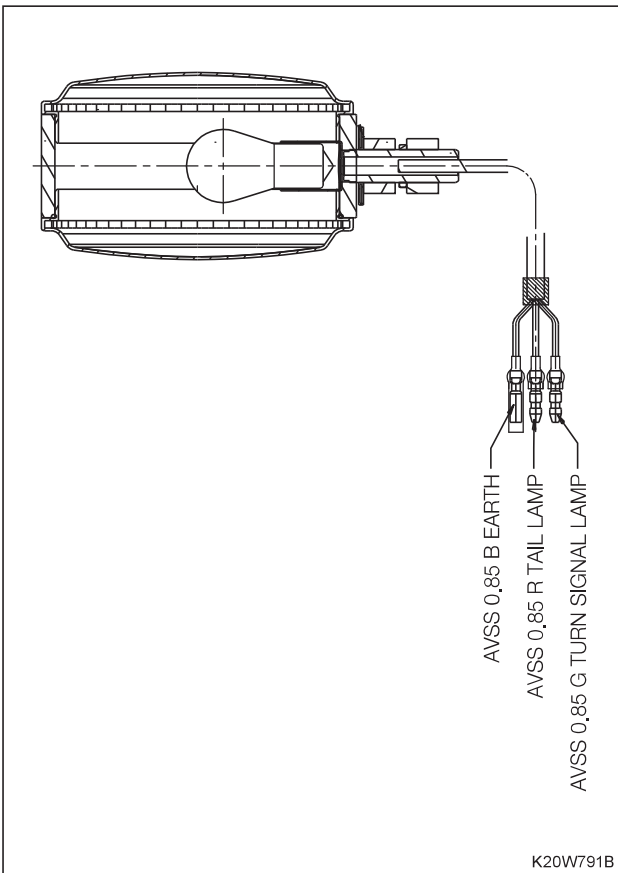

K20W791B

1. Unscrew the front turn signal lamp mounting nut (1) to separate the front turn signal lamp. Then, pull the lamp to disconnect the connector.
  2. Replace it with a new one.
- Bulb specification: 12 V 21 W/5 W

► EU

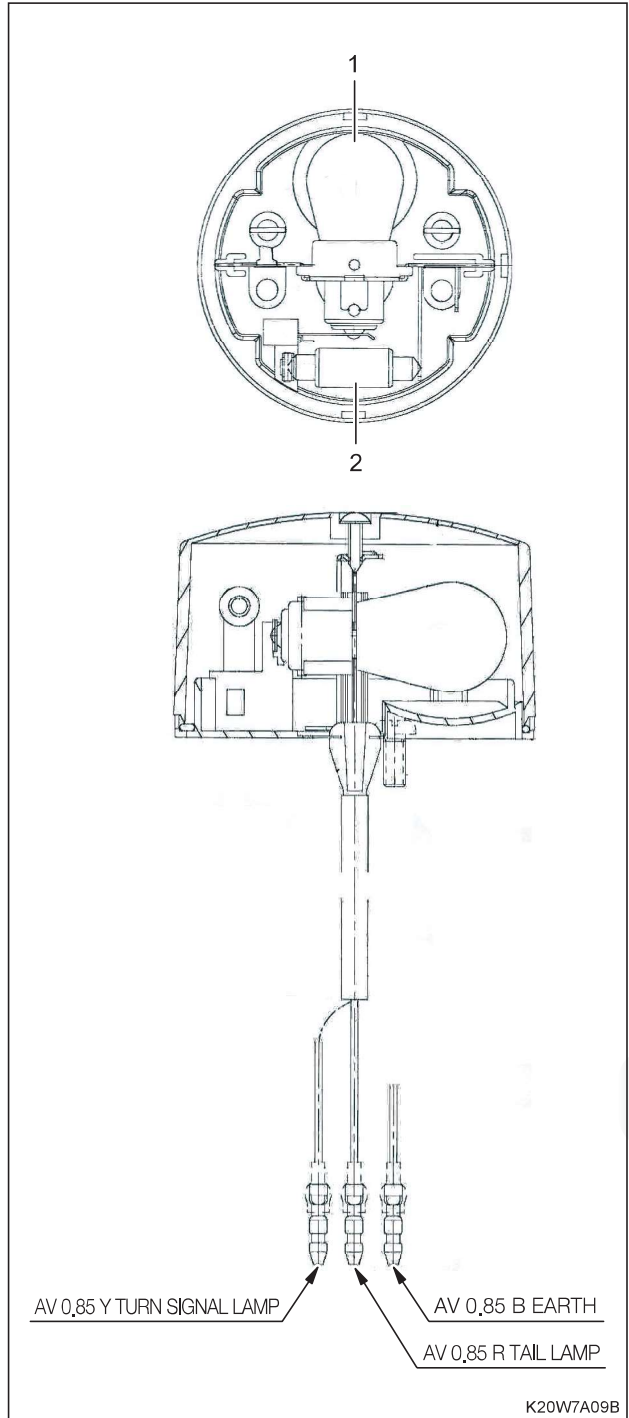

K20W7A09B

- Bulb specification: ① 12 V 21 W  
② 12 V 5 W

5.3.3 REAR COMBINATION LAMP (EU MODEL)

▶ COVER SIDE DISASSEMBLY



1. Remove the cover (1) on the bottom of the fender.



2. Unscrew the grommet assembly (1) clockwise to remove it.

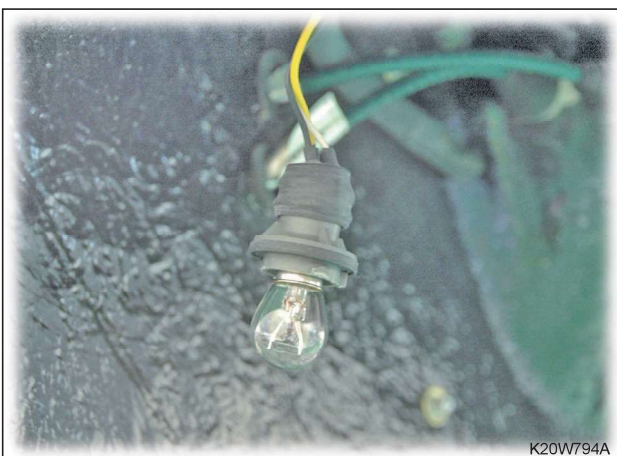

3. Remove the bulb.

Bulb specification: 12 V 21 W  
12 V 12 W/5 W

▶ LENS DISASSEMBLY

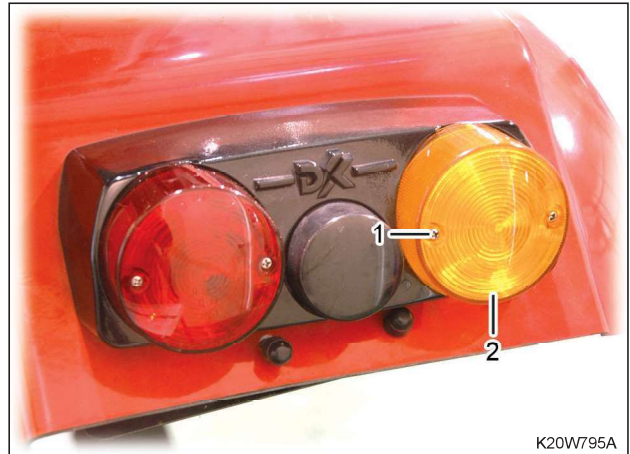

1. Unscrew the lens mounting screws (1) of the rear combination lamp and pull the lens (2) to remove it.



2. Remove the bulb (1) by pressing and turning it.



3. Replace the bulb with a new one.

Bulb specification: Right - 12 V 21 W/5 W (brake/tail lamp)

Left - 12 V 12 W (turn signal lamp)

► US

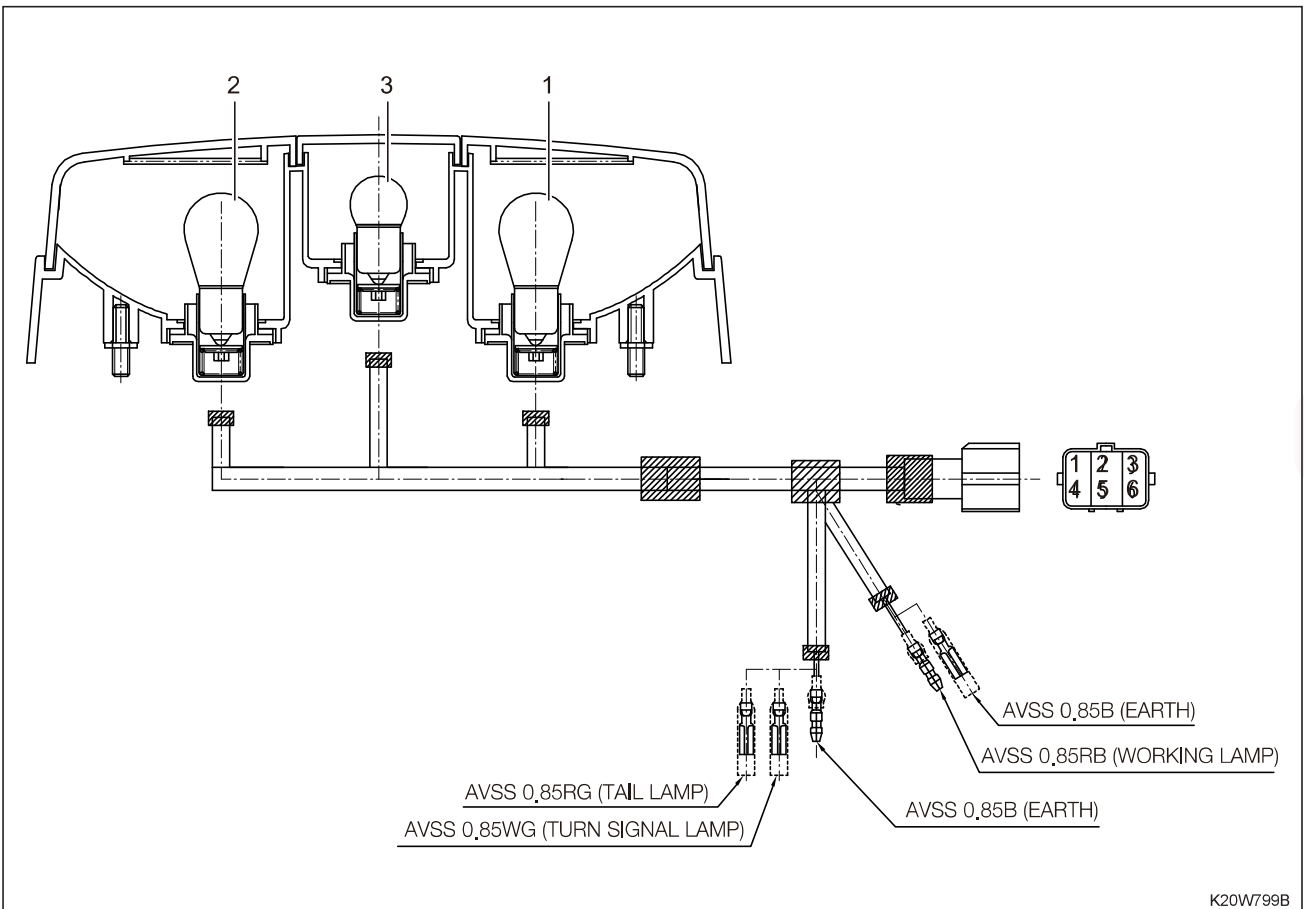

- Bulb specification: ① Right - 12 V 27 W (turn signal lamp)
- ② Left - 12 V 21 W/5 W (brake/tail lamp)
- ③ Middle - 12 V 8 W (Backup lamp (work lamp))

5.3.4 WORK LAMP



1. Turn the work lamp socket (1) counterclockwise to remove it.

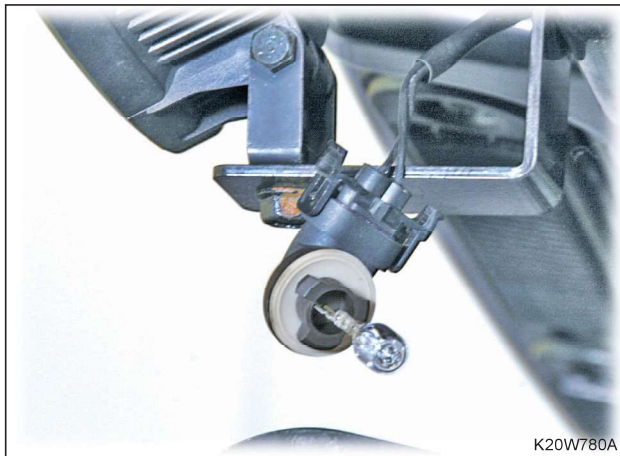

2. Disconnect the socket and connector.

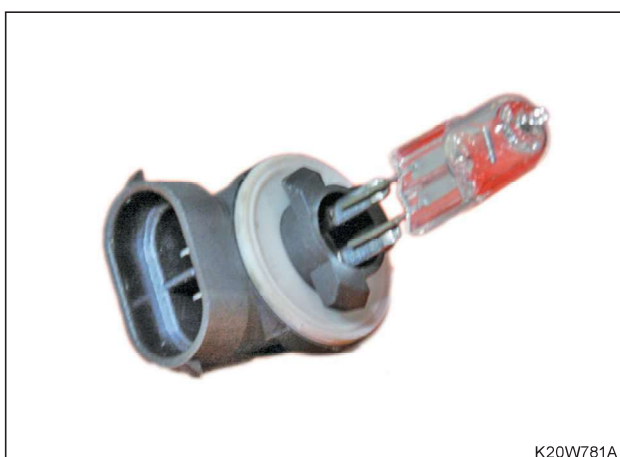

3. Replace the bulb with a new bulb.  
Bulb specification: 12 V 27 W

► ROPS WORK LAMP

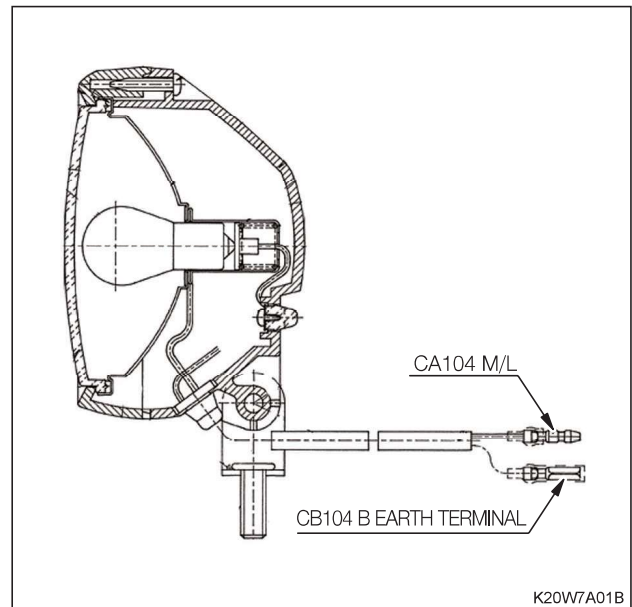

- Bulb specification: 12 V 20 W

5.4 WIRING DIAGRAM  
5.4.1 BODY WIRING DIAGRAM

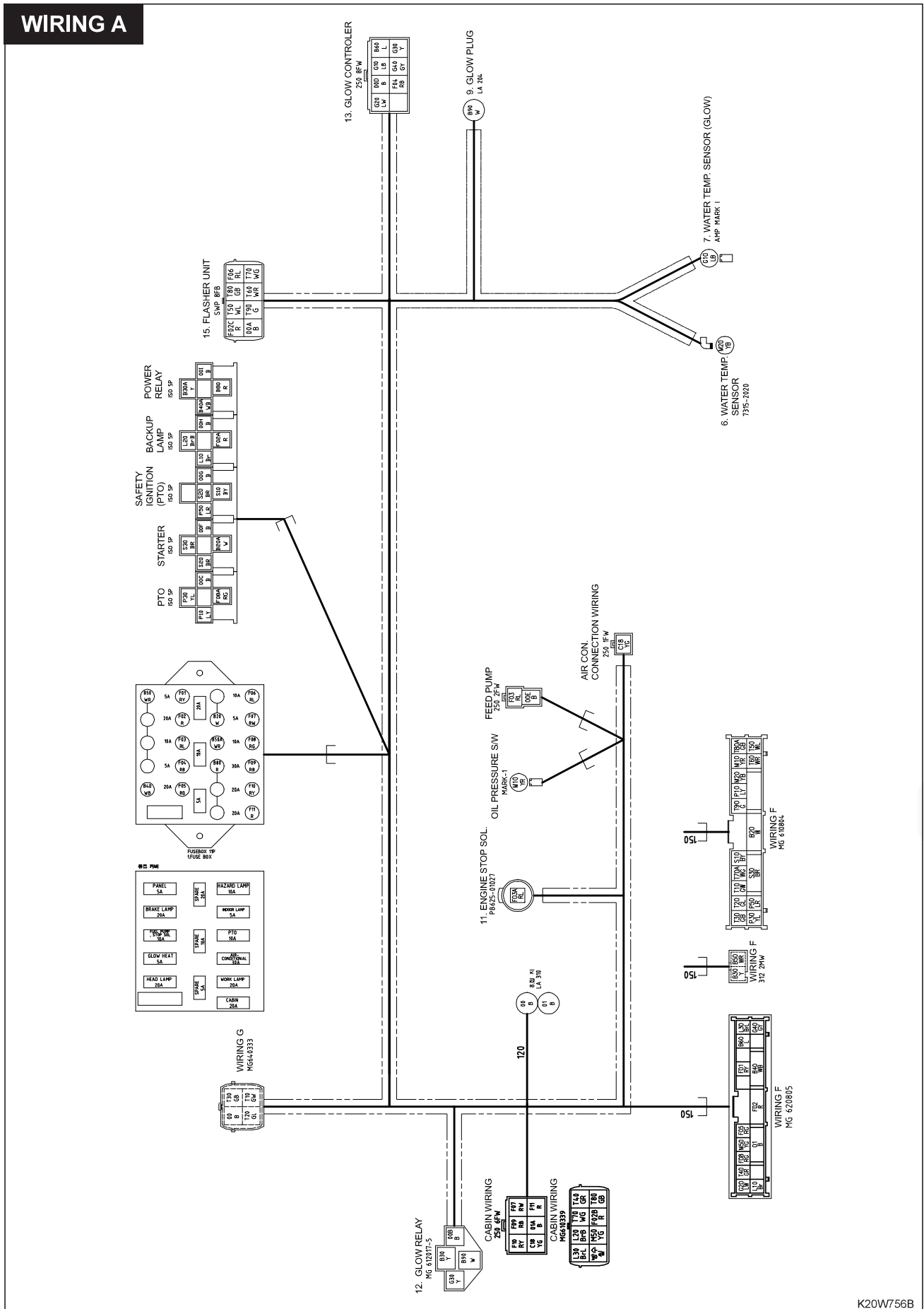

WIRING B

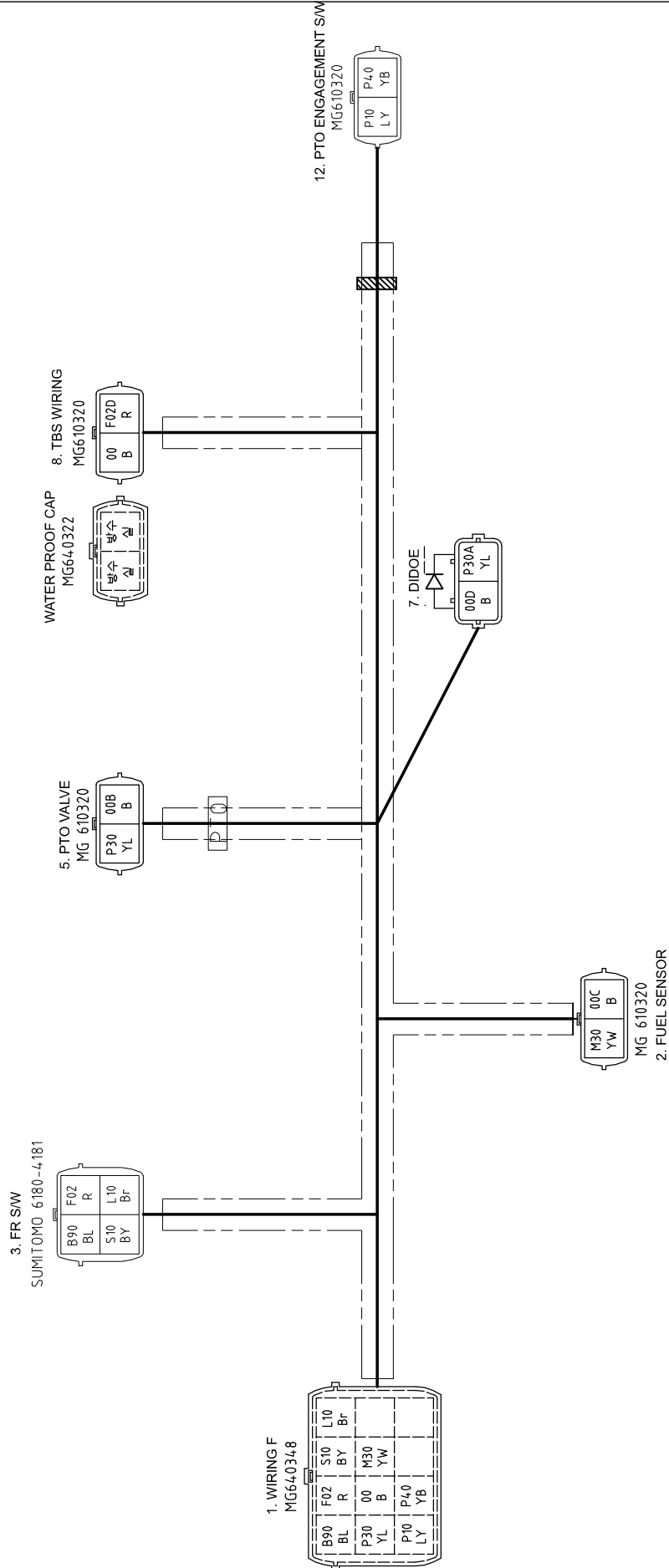

K20W757B

WIRING F

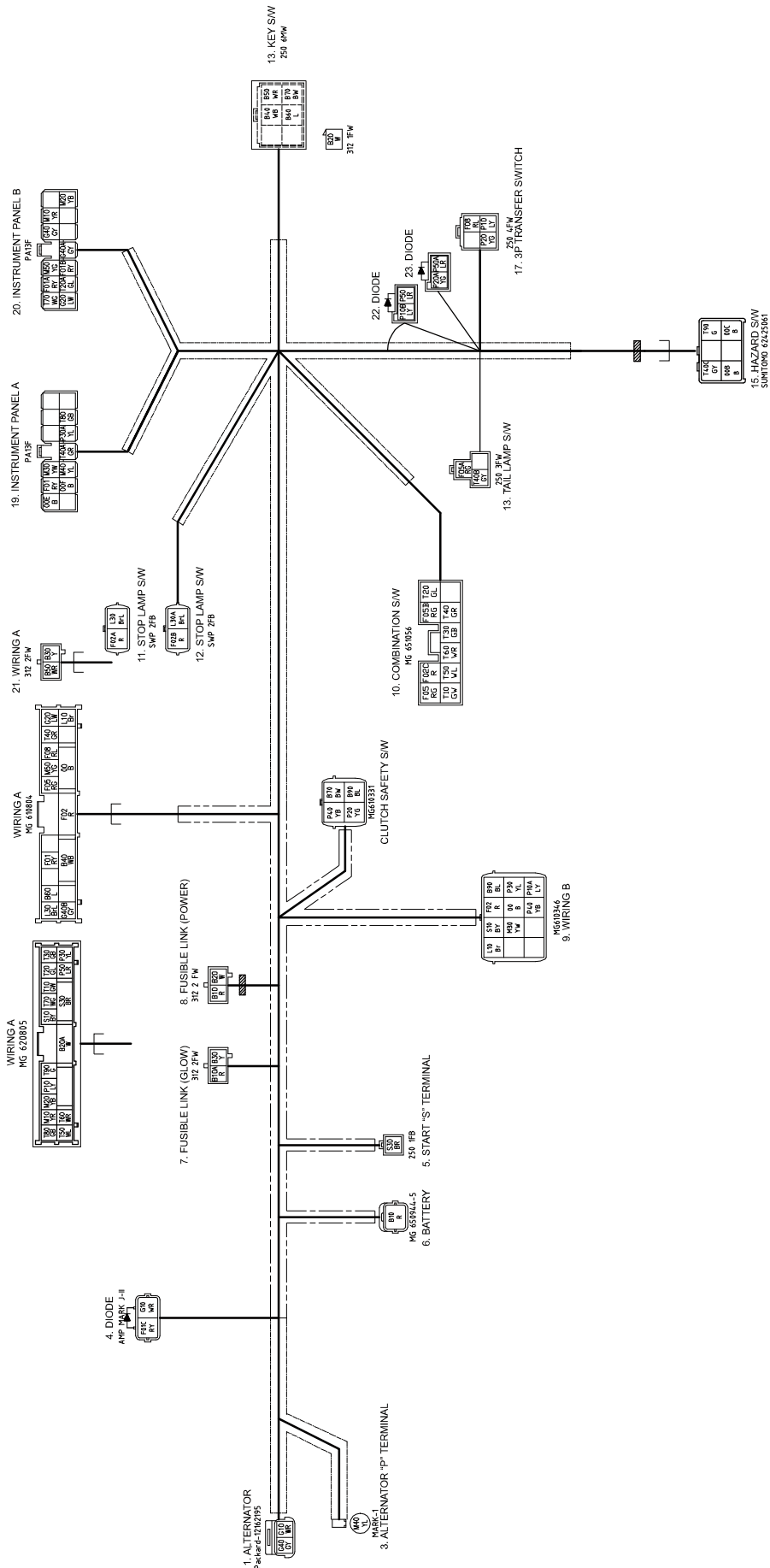

K20W758B

**WIRING G**

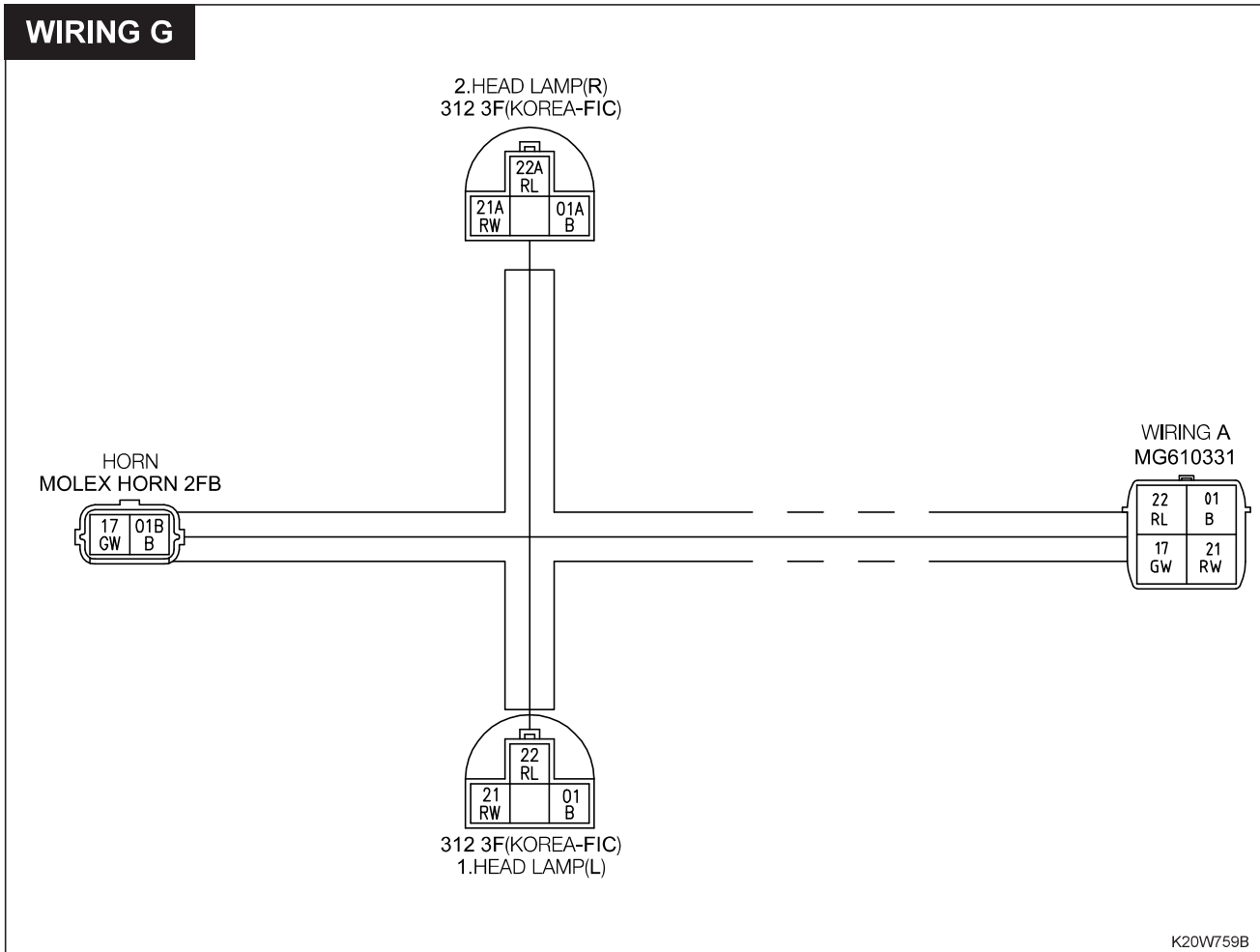

5.4.2 CABIN WIRING DIAGRAM

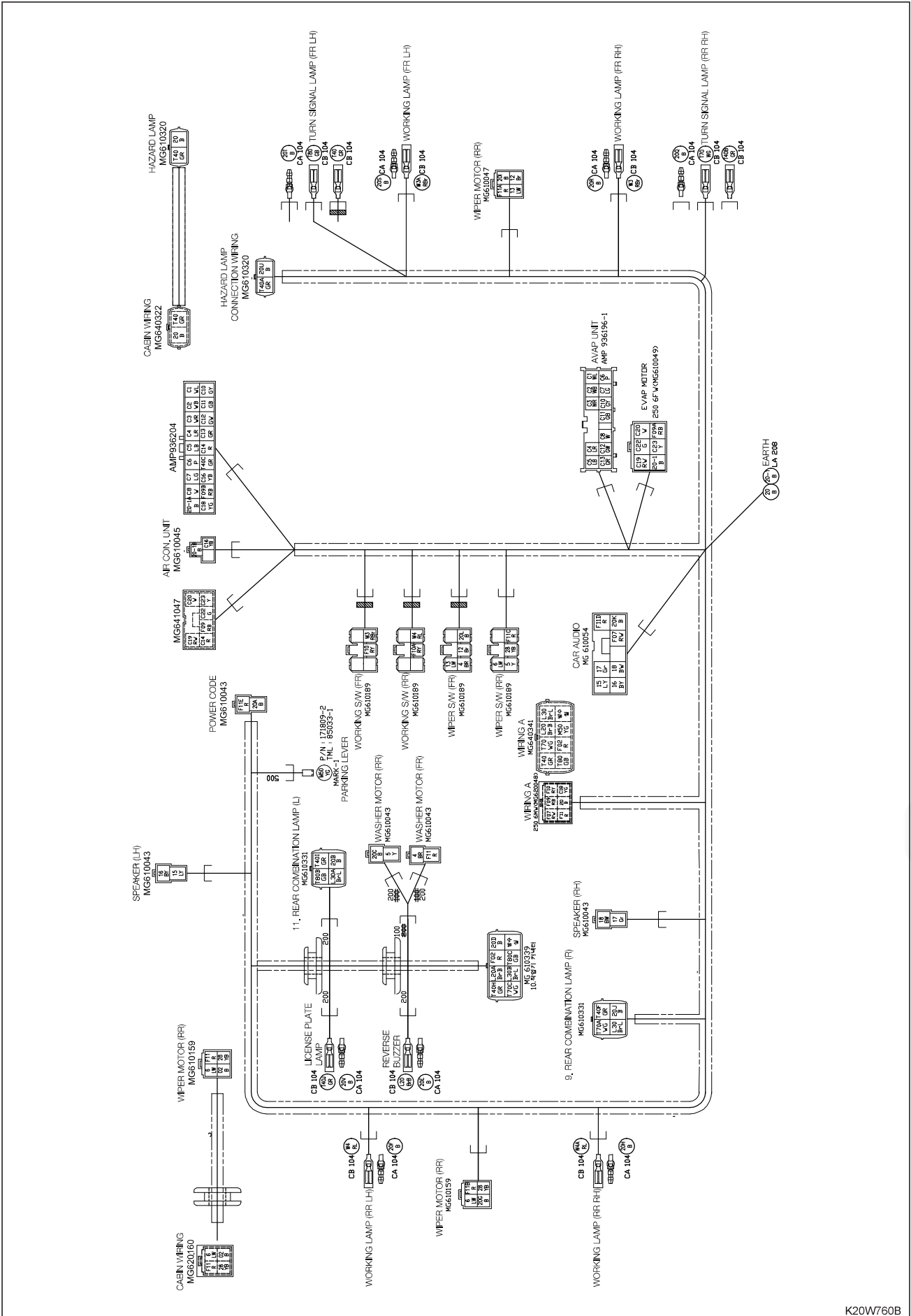

K20W760B

6. SECTIONAL VIEW FOR MAJOR COMPONENTS

6.1 SWITCH

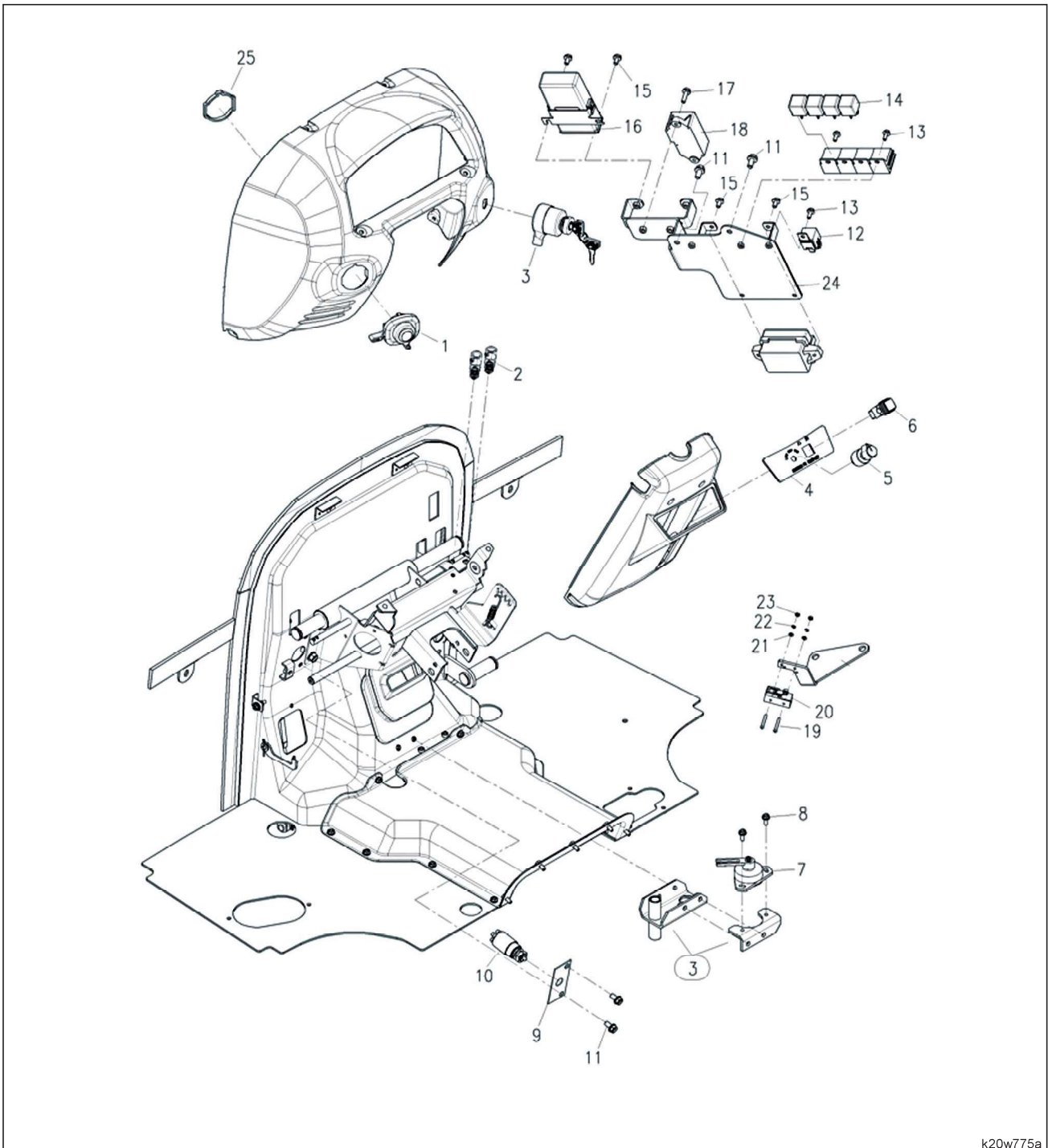

k20w775a

COMPONENTS

- |                                     |                       |  |
|-------------------------------------|-----------------------|--|
| (1) Combination switch assembly     | (10) Safety switch    | (19) Mounting screw (small cross type) |
| (2) Stop lamp switch                | (11) Hex. flange bolt | (20) PTO engagement switch             |
| (3) Start switch assembly           | (12) Preheat relay    | (21) Plain washer                      |
| (4) Switch panel C (domestic model) | (13) Hex. flange bolt | (22) Spring washer                     |
| (5) 4WD/QT switch                   | (14) Relay 5P         | (23) Hex. nut                          |
| (6) Hazard warning flasher switch   | (15) Hex. flange bolt | (24) Electric system bracket assembly  |
| (7) Switch (FR)                     | (16) QGS controller   | (25) Combination switch holder         |
| (8) Hex. flange bolt                | (17) Hex. flange bolt |  |
| (9) Switch mounting plate           | (18) Flash relay      |  |

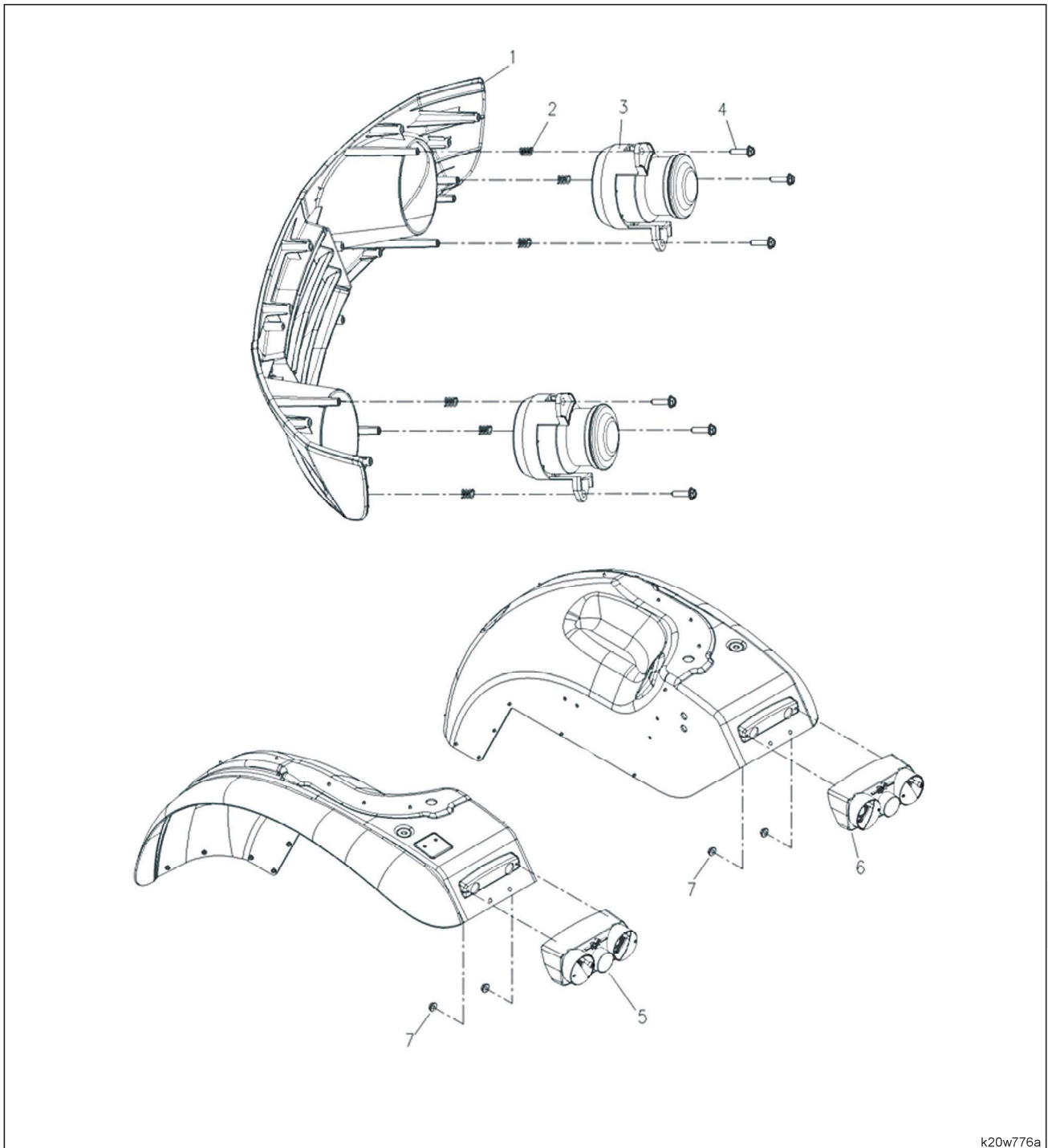

k20w776a

**COMPONENTS**

- (1) Front mask
- (2) Headlamp
- (3) Headlamp

- (4) Hex. flange tapping bolt
- (5) Combination lamp (LH)
- (6) Combination lamp (RH)

- (7) Hex. flange nut

7. TROUBLESHOOTING

INSPECTION ITEM  SYMPTOM	Safety Switch	Safe start Relay	Ignition switch	Controller	Starter Motor	Battery	Fuse and fusible link	Fuel cut-off solenoid	Preheat Controller	Preheat Relay	Coolant temperature sensor	Alternator	Instrument panel	Light bulb	Fuse	Flasher unit
The engine cannot be started (start motor operated)					●	●		●								
The engine cannot be started (start motor not operated)	●	●	●	●	●	●	●									
The engine can be started without depressing the clutch pedal.				●						●						
The engine cannot be stopped.								●								
The preheat indicator does not come on.							●		●	●	●		●			
The preheat indicator does not go off.									●	●						
The charge warning lamp does not come on.							●					●	●			
The charge warning lamp does not go off.												●				
The headlamp does not come on.													●	●		
The turn signal lamp does not come on.													●	●	●	
The horn does not sound.														●		

# CHAPTER 8 CABIN AND HVAC SYSTEM (CABIN MODEL ONLY)

## TABLE OF CONTENTS

<b>1. CABIN .....</b>	<b>8-2</b>	<b>2. HVAC SYSTEM .....</b>	<b>8-22</b>
1.1 Roof components .....	8-2	2.1 Specifications .....	8-22
1.2 Major component inspection .....	8-3	2.2 HVAC system flow diagram .....	8-23
1.2.1 Wiper switch .....	8-3	2.3 HVAC system inspection .....	8-24
1.2.2 Wiper motor .....	8-3	2.3.1 Refrigerant gauge test.....	8-24
1.2.3 Washer pump .....	8-5	2.3.2 Refrigerant maintenance .....	8-28
1.3 Sectional view for major components....	8-6	2.4 Sectional view for major components..	8-30
1.3.1 Fender assembly .....	8-6	2.4.1 A/C duct assembly .....	8-30
1.3.2 Pillar cover assembly.....	8-7	2.4.2 Cabin A/C assembly .....	8-31
1.3.3 Windshield assembly.....	8-8	2.4.3 Body A/C assembly .....	8-32
1.3.4 Door assembly.....	8-9	2.4.4 Compressor .....	8-33
1.3.5 Side and rear glass assembly .....	8-10	2.5 Component disassembly and assembly ..	8-34
1.3.6 Roof assembly.....	8-11	2.5.1 Air conditioner (evaporator) disassembly..	8-34
1.3.7 Ceiling assembly .....	8-12	2.5.2 Receiver drier removal .....	8-35
1.4 Component disassembly and assembly..	8-13	2.5.3 Compressor removal .....	8-36
1.4.1 Wiper switch .....	8-13	2.5.4 Condenser removal .....	8-37
1.4.2 Roof removal .....	8-13	2.6 Troubleshooting .....	8-39
1.4.3 Main cover (RH) removal.....	8-14	2.6.1 General information.....	8-39
1.4.4 Main cover (LH) removal .....	8-15	2.6.2 Cooling problem .....	8-39
1.4.5 Pillar disassembly.....	8-15	2.6.3 Heating problem .....	8-42
1.4.6 Front wiper motor removal.....	8-16		
1.4.7 Other component removal.....	8-17		
1.5 Troubleshooting .....	8-20		