

**SERVICE MANUAL**  
**064 and 066**  
**Chain Saws**

As the design concept of these two models is almost identical, the descriptions and servicing procedures generally apply to both. Differences are described in detail.

You should make use of the illustrated parts lists while carrying out repair work. They show the installed positions of the individual components and assemblies. Microfilmed parts lists are always more up to date than printed lists.

A fault on the machine may have several causes. Consult the "troubleshooting charts" when tracing faults.

Refer to the "Technical Information Bulletins" for engineering changes which have been introduced since publication of this service manual.

Service manuals and technical information bulletins describing engineering changes are intended exclusively for the use of STIHL servicing dealers and staff and must not be passed on to third parties.

Chain saw on assembly stand



Servicing and repairs are made considerably easier if the saw is mounted on assembly stand 5910 850 3100 or 5910 890 3100. This enables the saw to be swivelled to the best position for the ongoing repair and thus leaves both hands free.

The saw is can be quickly secured to the stand by means of the two bar mounting studs and nuts.

The STIHL Special Tools manual lists all special servicing tools currently available from STIHL.

**Always use original STIHL replacement parts.**

Original STIHL parts can be identified by the STIHL part number, the **STIHL** logo and the STIHL parts symbol. . The symbol may appear alone on small parts.

**STIHL**<sup>®</sup>

© 1992 Andreas Stihl. Waiblingen

## CONTENTS

1.	<b>Specifications</b>	3	4.6	Leakage Testing the Crankcase	41	9.	<b>Electric Handle Heating System</b>	64
1.1	Engine	3	4.6.1	Preparations	41	9.1	Troubleshooting	64
1.2	Fuel System	4	4.6.2	Pressure Test	42	9.1.1	Troubleshooting Chart	65
1.3	Ignition System	5	4.6.3	Vacuum Test	43	9.1.2	Test Connections and Test Values	66
1.4	Cutting Attachment	5	4.7	Replacing the Oil Seals	44	9.2	Switch	67
1.5	Tightening Torques	7				9.3	Heating Element in Rear Handle	67
1.6	Special Accessories	8	5.	<b>Ignition System</b>	45	9.4	Heating Element in Front Handle	68
1.6.1	For User	8	5.1	Repairing Component Parts	46	9.5	Generator	69
1.6.2	For Service	8	5.1.1	Spark Plug	46			
			5.1.2	Ignition Lead/Spark Plug Terminal	48	10.	<b>Chain Lubrication</b>	72
2.	<b>Troubleshooting Charts</b>	9	5.1.3	Short Circuit Wire/ Ground Wire	49	10.1	Pickup Body	72
2.1	Clutch, Chain Drive Chain Brake and Chain Tensioner	9	5.1.4	Stop Contact	51	10.2	Suction Hose	73
2.2	Engine	10	5.1.5	Flywheel	52	10.3	Vent Valve	73
2.3	Ignition System	11	5.1.6	Ignition Module	53	10.4	Removal and Installation of Oil Pump	73
2.4	Rewind Starter	12	5.1.6.1	Ignition Timing	54	10.5	Servicing the Oil Pump	75
2.5	Chain Lubrication	13	5.1.6.2	Removing and Installing	54			
2.6	Fuel System	14	5.1.7	LED (066 only)	55	11.	<b>Fuel System</b>	76
3.	<b>Clutch, Chain Drive Chain Brake and Chain Tensioner</b>	16	6.	<b>Rewind Starter</b>	56	11.1	Air Filter	76
3.1	Clutch Drum/Chain Sprocket	16	6.1	Routine Maintenance	56	11.2	Construction and Operation of Carburetor with Compensator	77
3.2	Clutch	17	6.2	Rope Rotor/Pawls	56	11.3	Leakage Testing the Carburetor	78
3.3	Chain Brake	19	6.3	Replacing the Starter Rope	57	11.4	Removal and Installation of Carburetor	79
3.3.1	Disassembly	19	6.4	Replacing the Rewind Spring	57	11.5	Servicing the Carburetor	80
3.3.2	Assembly	21	6.5	Tensioning Rewind Spring	58	11.6	Carburetor Adjustment (Analog Ignition)	85
3.4	Chain Tensioner	23	6.6	Replacing Starter Rope Guide Bush	59	11.7	Carburetor Adjustment (Digital Ignition)	86
3.5	Bar mounting studs	24				11.8	Tank Vent	87
4.	<b>Engine</b>	25	7.	<b>AV Handle System</b>	60	11.9	Fuel Filter and Fuel Hose	88
4.1	Removing and Refitting Exhaust Muffler	25	7.1	Repair	60	11.10	Tank Housing	89
4.2	Exposing the Cylinder	26				11.11	Carburetor Box	91
4.3	Cylinder and Piston	26	8.	<b>Master Control</b>	61			
4.3.1	Removal	26	8.1	Construction and Function	61	12.	<b>Special Servicing Tools and Aids</b>	92
4.3.2	Installation	27	8.2	Throttle Trigger/Interlock Lever	62	12.1	Special Servicing Tools	92
4.4	Piston Rings	31	8.2	Switch Shaft	63	12.2	Servicing Aids	93
4.5	Crankcase	32						
4.5.1	Removing the Crankshaft	32						
4.5.2	Installing the Crankshaft	35						

## 1. SPECIFICATIONS

1.1 Engine	<b>064</b>	<b>066</b>
	STIHL single-cylinder two-stroke engine	
Displacement:	85 cm <sup>3</sup> (5.2 cu.in)	91.6 cm <sup>3</sup> (5.6 cu.in)
Bore:	52 mm (2.05 in)	54 mm (2.12 in)
Stroke:	40 mm (1.6 in)	40 mm (1.6 in)
Compression ratio:	10.0	10.0
Power output:	4.8 kW (6.5 bhp) at 9,500 rpm	5.0 kW (6.8 bhp) at 9,500 rpm
Max. torque:	5.45 Nm (4.0 lb.ft) at 6,500 rpm	5.6 Nm (4.1 lb.ft) at 6,500 rpm
Cylinder bore:	Highly wear-resistant electroplated coating	
Max. permissible engine speed with bar and chain:	12,000 rpm	
Cut-off speed:		13,500 rpm
Mean idle speed:	2,400 rpm	2,400 rpm
Crankshaft:	Two-part, drop forged	Two-part, drop forged
Crankshaft bearings:	2 deep groove ball bearings	2 deep groove ball bearings
Crankpin diameter:	16 mm (0.63 in)	16 mm (0.63 in)
Big-end bearing:	Needle cage	Needle cage
Piston pin dia.:	12 mm (0.47 in)	12 mm (0.47 in)
Small-end bearing:	Needle cage	Needle cage
Conrod length:	68 mm (2.67 in)	68 mm (2.67 in)
Rewind starter:	Two-pawl system with automatic starter rope rewind mechanism	
Starter rope:	4.5 mm (0.18 in) dia., length 1000 mm (39.4 in)	
Clutch:	Centrifugal clutch without linings, 82 mm (3.2 in) dia.	Centrifugal clutch without linings, 82 mm (3.2 in) dia.
Clutch engages at:	approx. 3,200 rpm	approx. 3,200 rpm
Crankcase leakage test at gauge pressure:	0.5 bar (7.25 psi)	0.5 bar (7.25 psi)
under vacuum:	0.5 bar (7.25 psi)	0.5 bar (7.25 psi)

---

1.2 Fuel System	064	066
Carburetor:	All position diaphragm carburetor with integral fuel pump	All position diaphragm carburetor with integral fuel pump
Basic setting		
High speed screw H:	Back off approx. 1 turn	Back off approx. 1 turn
Low speed screw L:	Back off approx. 1 turn (starting with screws tight against their seats)	Back off approx. 1 turn (starting with screws tight against their seats)
Carburetor leakage test at gauge pressure:	0.4 bar (5.8 psi)	0.4 bar (5.8 psi)
Fuel tank capacity:	0.84 l (1.77 US pt)	0.84 l (1.77 US pt)
Fuel mixture:	Regular brand-name gasoline and brand-name two-stroke engine oil	
Mix ratio:	<b>50:1</b> with STIHL two-stroke engine oil 25:1 with other brand-name two-stroke, air-cooled engine oils	<b>50:1</b> with STIHL two-stroke engine oil 25:1 with other brand-name two-stroke, air-cooled engine oils
Compensator:		Keeps pressures equal at clean air side of filter and metering diaphragm irrespective of how dirty the filter is
Air filter:	Standard (wire mesh) element Special accessory: Heavy duty (HD)-air filter	Standard (wire mesh) element Special accessory: Heavy duty (HD)-air filter

## 1.3 Ignition System

	064	066
Type:	Electronic magneto ignition (breakerless) with integral trigger unit	Digital magneto ignition (breakerless) with maximum speed governor
Air gap:	0.2-0.3 mm (0.008-0.012 in)	0.2-0.3 mm (0.008-0.012 in)
Ignition timing:	2.6-3.4 mm (0.10-0.13 in) B.T.D.C. at 8,000 rpm	2.9-3.9 mm (0.11-0.15 in) B.T.D.C. at 8,000 rpm
Advance angle:	26°-30° B.T.D.C. at 8,000 rpm	27.5°-32.5° B.T.D.C. at 8,000 rpm
Spark plug (suppressed):	Bosch WSR 6 F or NGK BPMR 7 A	Bosch WSR 6 F or NGK BPMR 7 A
Electrode gap:	0.5 mm (0.020 in)	0.5 mm (0.020 in)
Spark plug thread:	M14 x 1.25	M14 x 1.25
Length of thread:	9.5 mm (0.37 in)	9.5 mm (0,37 in)
Heat range:	200	200
LED:		Aids carburetor adjustment

## 1.4 Cutting Attachment

Guide bars:	STIHL Rollomatic S bars with sprocket nose. STIHL Duromatic bars with stellite-tipped nose. Both types with corrosion-resistant finish and induction hardened rails.	STIHL Rollomatic S bars with sprocket nose. STIHL Duromatic bars with stellite-tipped nose. Both types with corrosion-resistant finish and induction hardened rails.
Bar lengths:	Rollomatic: 40, 45, 50, 63, 75 and 90 cm (16, 18, 20, 25, 30 and 35 in) Duromatic: 40, 45, 50, 63 and 75 cm (16, 18, 20, 25 and 30 in)	Rollomatic: 40, 45, 50, 63, 75 and 90 cm (16, 18, 20, 25, 30 and 35 in) Duromatic: 40, 45, 50, 63 and 75 cm (16, 18, 20, 25 and 30 in)

	<b>064</b>	<b>066</b>
Oilomatic chain:	3/8" (9.32 mm) Rapid Micro and Super (standard) 0.404" (10.26 mm) Rapid Micro and Rapid Super (optional)	3/8" (9.32 mm) Rapid Micro and Super (standard) 0.404" (10.26 mm) Rapid Micro and Rapid Super (optional)
Chain sprocket:	8-tooth 3/8" rim or spur sprocket (alternatives) 7-tooth 0.404" spur or rim sprocket (optional)	8-tooth 3/8" rim or spur sprocket (alternatives) 7-tooth 0.404" spur or rim sprocket (optional)
Chain speed:	23.6 m/s (77.4 ft/s) at 9,500 rpm (with 8-tooth 3/8" chain sprocket)	23.6 m/s (77.4 ft/s) at 9,500 rpm (with 8-tooth 3/8" chain sprocket)
Chain lubrication:	Fully automatic, speed- controlled reciprocating oil pump, no feed at idle speed. Additional manual oil flow control.	Fully automatic, speed- controlled reciprocating oil pump, no feed at idle speed. Additional manual oil flow control.
Oil feed rate, adjustable:	11-21.5 cc/min (3/8-3/4 fl.oz/min) at 10,000 rpm	11-21.5 cc/min (3/8-3/4 fl.oz/min) at 10,000 rpm
Oil tank capacity:	0.35 l (0.74 US pt)	0.35 l (0.74 US pt)

## 1.5 Tightening Torques

Fastener	Thread size	For component	Torque		Remarks
			Nm	(lbf.ft)	
Spline screw	IS-M5x20	Crankcase	9.0	(6.6)	
Spline screw	IS-M5x20	Cylinder	12.0	(8.8)	
Spline screw	IS-M6x20	Cylinder	15.0	(11.8)	4)
Spline screw	IS-M5x12	Muffler to cylinder	10.0	(7.5)	1)2)
Spline screw	IS-M6x20	Muffler to cylinder	15.0	(11.0)	4)
Spline screw	IS-M5x6	Muffler upper casing (top)	11.0	(8.1)	1)2)
Spline screw	IS-M5x12	Muffler upper casing (bottom)	8.0	(5.9)	1)2)
Spline screw	IS-M5x20	Ignition module	9.0	(6.6)	1)2)
Nut	M8x1	Crankshaft (flywheel)	33.0	(24.3)	
Flange locknut	VM 5	Carburetor	3.5	(2.6)	
Spline screw	IS-M4x16	Shroud	3.0	(2.2)	1)2)
	M12x1 L	Clutch carrier	50.0	(37.0)	
	M14x1.25	Spark plug	25.0	(18.5)	
Spline screw	IS-6x19	Annular buffer (top)	3.5	(2.6)	
Spline screw	IS-6x19	Annular buffer (bottom)	7.0	(5.2)	
Spline screw	IS-5.8x19	Front handle	7.0	(5.2)	2)3)
Self-tapping screw	B3.9x19	Handle molding	1.0	(0.75)	
Spline screw	IS-M5x12	Annular buffer plate	9.0	(6.6)	1)
Spline screw	IS-M5x16	Chain catcher	7.0	(5.2)	
Spline screw	IS-M5x12	Spiked bumper (top)	7.0	(5.2)	
Spline screw	IS-M5x16	Chain catcher pin to spiked bumper	6.0	(4.4)	
Spline screw	IS-M5x12	Rubber buffer to crankcase	3.5	(2.6)	
Locknut	M5	Spiked bumper to sprocket cover	8.0	(5.9)	
Pan head screw	BM3x8	Guard in sprocket cover	1.0	(0.75)	
Pan head screw	M3.5x12	Generator (heating)	2.0	(1.5)	
Pan head screw	M4x12	Cover (chain tensioner)	3.5	(2.6)	
Spline screw	IS-M4x12	Oil pump	3.0	(2.2)	
Spline screw	IS-M4x12	Cover (chain brake)	2.0	(1.5)	
Spline screw	IS-M5x18	Fan housing	3.5	(2.6)	
Spline screw	IS-M5x12	Starter post in fan housing	6.0	(4.4)	
Starter post	M8	Fan housing	6.0	(4.4)	
Screw assy.	IS-M5x30	Hand guard (left)	7.0	(5.2)	1)
Pan head screw	M4x8	Inner side plate	3.0	(2.2)	
Collar stud	M8	Guide bar mounting	15.0	(11.0)	1)

**Remarks:**

- 1) Screw must be secured with adhesive 0786 111 1101 (Loctite 242).
- 2) Washer must be fitted under screw head. On front handle, fit washer under heads of side screws only.
- 3) Screw must be secured with adhesive 0786 111 1117 (Loctite 648).
- 4) Model 066 only.

**Note:** Screws secured with adhesive are easier to release if the adhesive is heated first with a hot air blower (hair dryer). **Exercise caution on polymer components.**

---

1.6	<b>Special Accessories</b>	<b>064 / 066</b>	
1.6.1	<b>For User</b>		
		STIHL repair kit 064	1122 900 5000
		Intake air preheating kit	1122 007 1027
		7-tooth 0.404" rim sprocket kit	1122 007 1002
		8-tooth 3/8" spur sprocket	1122 640 2000
		7-tooth 0.404" spur sprocket	1122 640 2001
		Valve (fuel tank vent)	1110 353 1600
		0.404" (10.26 mm) Oilomatic chains	
		Spiked bumpers for thick bark	
1.6.2	<b>For Service</b>		
		Carburetor parts kit 064	1122 007 1060
		Gasket set 064/066	1122 007 1051

## 2. TROUBLESHOOTING CHARTS

### 2.1 Clutch, Chain Drive, Chain Brake and Chain Tensioner

Condition	Cause	Remedy
Saw chain turns at idle speed	Engine idle speed too high	Readjust at idle speed adjustment screw (counterclockwise)
	Spring hook(s) broken	Fit new spring(s)
Loud noises	Springs stretched or fatigued	Replace all clutch springs
	Needle cage damaged	Fit new needle cage
	Clutch shoe retainer broken	Fit new retainer
	Clutch shoes and carrier worn	Fit new clutch
Chain sprocket wears rapidly	Chain not properly tensioned	Tension chain as specified
Chain wears rapidly	Chain not properly tensioned	Tension chain as specified
	Poor chain lubrication rectify problem	Check chain lubrication and
	Worn chain sprocket	Fit new sprocket
Chain does not stop immediately when chain brake is activated	Brake spring broken	Fit new brake spring
	Brake band stretched or broken	Fit new brake band

## 2.2 Engine

Always check and, if necessary, repair the following parts before looking for faults on the engine:

- Air filter
- Fuel system
- Carburetor
- Ignition system

Condition	Cause	Remedy
Engine does not start easily, stalls at idle speed, but operates normally at full throttle	Oil seals in crankcase leaking	Replace oil seals
	Manifold leaking	Seal or replace manifold
	Cylinder base gasket leaking	Replace gasket
	Crankcase damaged (cracks)	Replace crankcase
Engine does not deliver full power or runs erratically	Secondary air seepage through poorly mounted or faulty manifold	Mount manifold correctly or replace
	Piston rings leaking or broken	Fit new piston rings
	Muffler carbonized	Clean muffler (inlet and exhaust), replace spark arrestor screen (if fitted)
Engine overheating	Insufficient cylinder cooling. Air inlets in fan housing blocked or cooling fins on cylinder very dirty	Thoroughly clean all cooling air openings
	Intake air preheating being used at too high an outside temperature	Remove intake air preheating components; close rotary shutter

2.3 Ignition System

**Warning:** Exercise extreme caution while carrying out maintenance and repair work on the ignition system. The high voltages which occur can cause serious or fatal accidents!

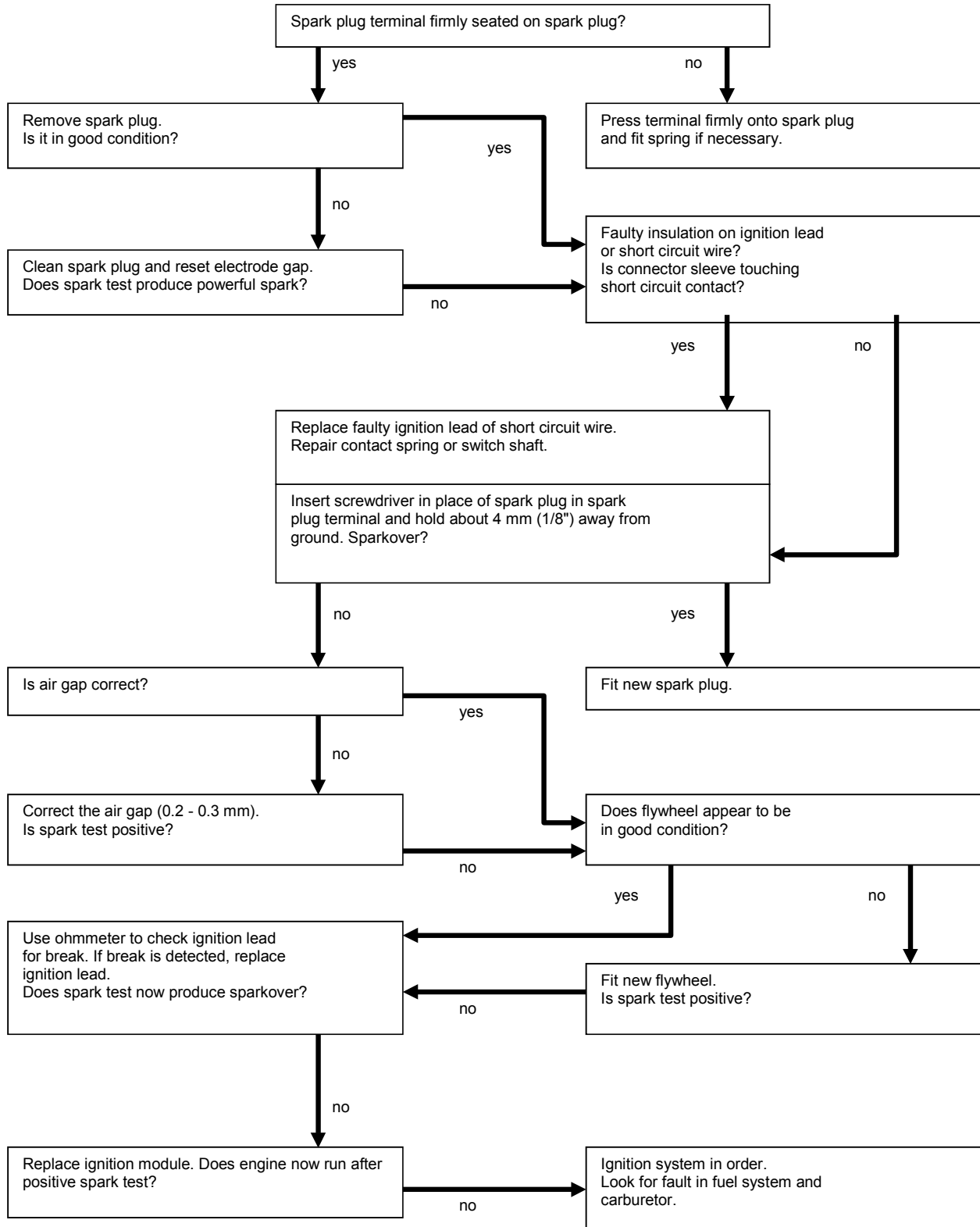

## 2.4 Rewind Starter

Condition	Cause	Remedy
Starter rope broken	Rope pulled out too vigorously as far as stop or over edge - i.e. not vertically	Fit new starter rope
	Normal wear	Fit new starter rope
Rewind spring broken	Spring overtensioned - no reserve when rope is fully extended	Fit new rewind spring
	Heavily soiled or corroded	Fit new rewind spring
Starter rope can be pulled out almost without resistance (crankshaft does not turn)	Guide pegs on pawls or pawls themselves are worn	Fit new pawls
	Spring clip fatigued	Fit new spring clip
Starter rope is difficult to pull and rewinds very slowly	Starter mechanism is very dirty (dusty conditions)	Thoroughly clean complete starter mechanism
	Lubricating oil on rewind spring becomes viscous at very low outside temperatures (spring windings stick together)	Apply a few drops of kerosine (paraffin) to spring, then pull rope carefully several times until normal action is restored

## 2.5 Chain Lubrication

**Important:** In the event of trouble with the chain lubrication system, always investigate the other possible sources of faults before disassembling the oil pump.

Condition	Cause	Remedy
Chain receives no oil	Oil tank empty	Fill up with oil
	Oil hose has come off stub on oil pump or out of crankcase recess, or hose is damaged*	Reconnect hose to pump or fit it in crankcase recess, or install a new hose.
	Sealing ring in crankcase recess is faulty**	Remove oil pump, fit new sealing ring and reinstall oil pump
	Oil inlet hole in guide bar is blocked	Clean oil inlet hole
	Intake hose or pickup body (strainer) clogged or intake hose ruptured	Wash intake hose and pickup body (strainer) in white spirit and blow out with compressed air; replace if necessary
	Valve in oil tank blocked	Clean or replace valve
Machine losing chain oil	Teeth on pump piston and/or worm worn	Fit new pump piston and/or new worm
	Oil hose has come off stub on oil pump or out of crankcase recess, or hose is damaged*	Reconnect hose to pump or fit it in crankcase recess, or install a new hose.
Oil pump delivers too little oil	Cylinder bore in pump housing worn	Fit new pump housing
	Control screw and/or control edge on pump piston worn	Fit new control screw and/or new pump piston
	Bore in pump housing worn	Fit new pump housing

\* Older machines

\*\* New machines

## 2.6 Fuel System

Condition	Cause	Remedy
Carburetor floods; engine stalls	Inlet needle not sealing. Foreign matter in valve seat or cone damaged.	Remove and clean or replace inlet needle, clean fuel tank, pickup body and fuel line if necessary
	Inlet control lever sticking on spindle	Free off inlet control lever
	Helical spring not located on nipple of inlet control lever	Remove inlet control lever and refit correctly
	Perforated disc on diaphragm is deformed and presses constantly against inlet control lever	Fit new metering diaphragm
	Inlet control lever is too high (relative to design position)	Set inlet control lever flush with top of metering chamber face
Poor acceleration	Idle jet "too lean"	Back off low speed adjusting screw slightly (see carburetor adjustment)
	Main jet "too lean"	Back off high speed adjusting screw slightly (see carburetor adjustment)
	Inlet control lever is too low (relative to design position)	Set inlet control lever flush with top of metering chamber face
	Inlet needle sticking to valve seat	Remove inlet needle, clean and refit
	Connecting bore to atmosphere blocked	Clean bore
	Diaphragm gasket leaking	Fit new diaphragm gasket
	Metering diaphragm damaged or shrunk	Fit new metering diaphragm
Engine will not idle, idle speed too high	Throttle valve opened too far by idle speed adjusting screw	Reset idle speed adjusting screw correctly

Condition	Cause	Remedy
Engine stalls at idle speed	Idle jet bores or channels blocked	Clean jet bores and blow out with compressed air
	Idle jet "too rich"	Screw in low speed adjusting screw slightly (see carburetor adjustment)
	Setting of idle speed adjusting screw incorrect - throttle shutter completely closed	Set idle speed adjusting screw correctly
	Small plastic plate in valve jet does not close	Clean or renew valve jet
Engine speed drops quickly under load - low power	Air filter plugged	Clean air filter
	Tank vent faulty	Clean tank vent or replace if necessary
	Leak in fuel line between tank and fuel pump	Seal or renew connections and fuel line
	Pump diaphragm damaged or fatigued	Fit new pump diaphragm
	Main jet bores or channels blocked	Clean bores and channels
	Fuel pickup body dirty	Clean pickup body, fit new filter
	Fuel strainers dirty	Clean fuel strainers

3. CLUTCH, CHAIN DRIVE, CHAIN BRAKE AND CHAIN TENSIONER

3.1 Clutch Drum/Chain Sprocket

Top:  
1 = Saw chain  
2 = Guide bar  
3 = Sprocket cover

Bottom:  
Disengaging chain brake

Top:  
Removing E-clip

Bottom:  
Removing clutch drum or chain sprocket

Top:  
Removing needle cage

Bottom:  
Assembly sequence of chain drive  
1 = Spur sprocket (with clutch drum)  
2 = Needle cage  
3 = Washer  
4 = E-clip  
5 = Clutch drum (for rim sprocket)  
6 = Rim sprocket

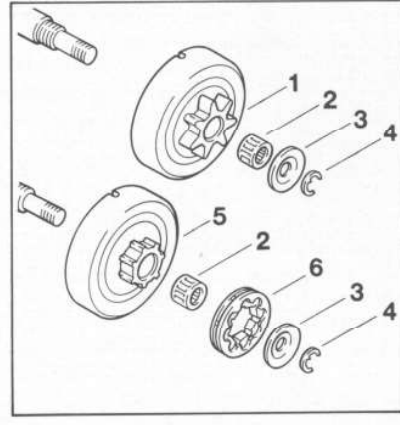
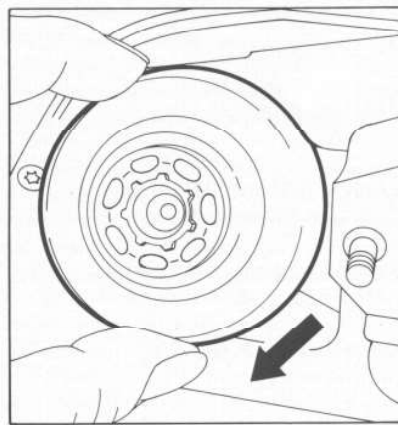
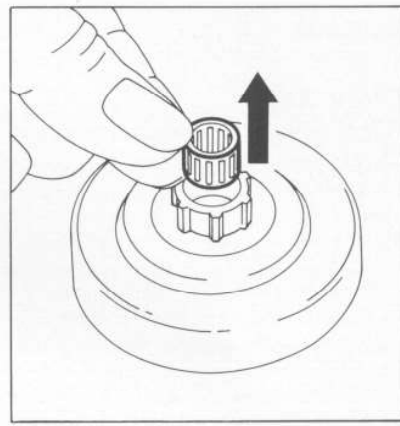
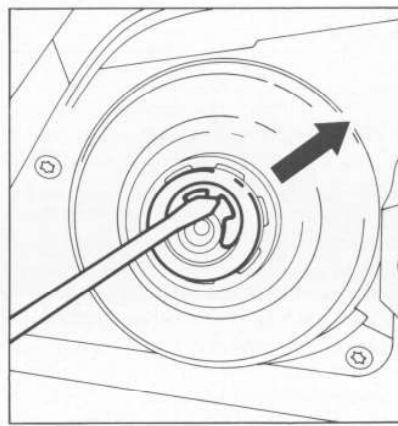
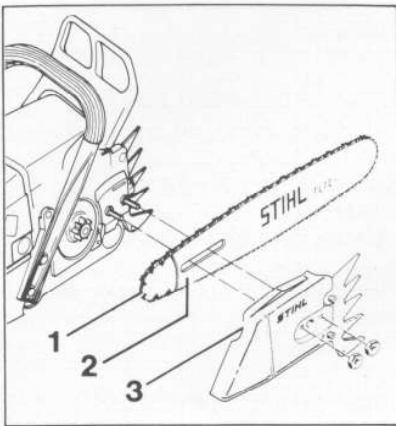

- Unscrew sprocket cover nuts and remove sprocket cover.
- Remove saw chain and guide bar.
- Disengage the chain brake by pulling the hand guard toward the front handle.

- Pry the E-clip off the crankshaft.
- Remove the washer from the clutch drum or chain sprocket.
- Pull off the rim sprocket with clutch drum or the spur sprocket.
- Take the needle cage out of the clutch drum or chain sprocket.

Reassemble in the reverse sequence.

**Caution:** Rim sprocket must be fitted with chip ejector cavities facing outward.

**Note:** Clean stub of crankshaft. Replace the needle cage or wash it in clean white spirit and lubricate with STIHL multipurpose grease, see 12.2. Rotate the clutch drum or spur sprocket, apply slight pressure at the same time, until the oil pump drive spring engages the slot on the outside diameter of the drum.

3.2 Clutch

Top:  
1 = Spark plug terminal  
2 = Spark plug

Bottom:  
Shroud mounting screws (third screw hidden in this view)

Top:  
Locking strip 0000 893 5902

Bottom:  
Locking strip in position

Top:  
Clutch

Bottom:  
Assembly hook 5910 890 2800

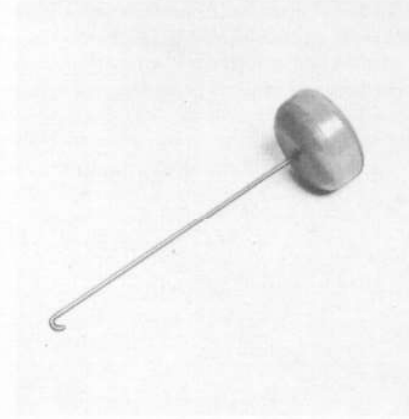
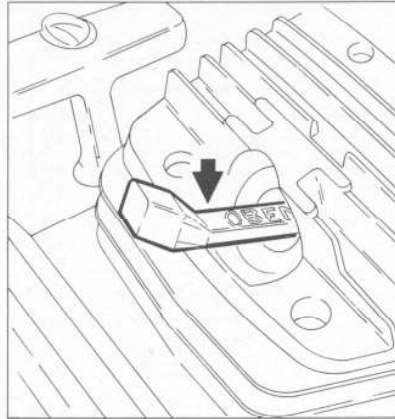
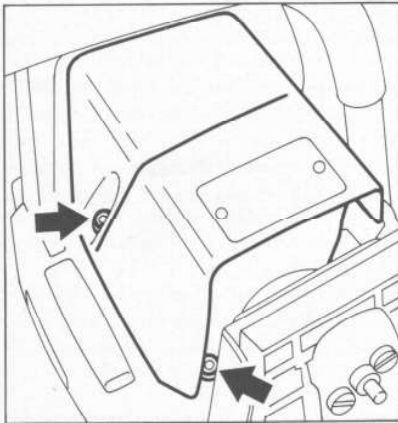
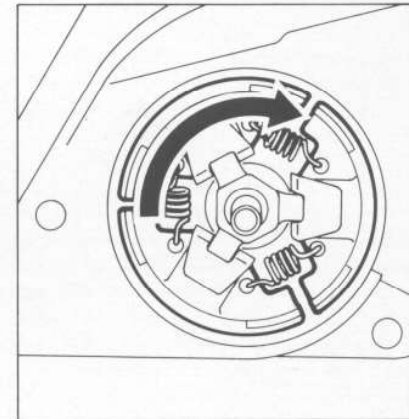
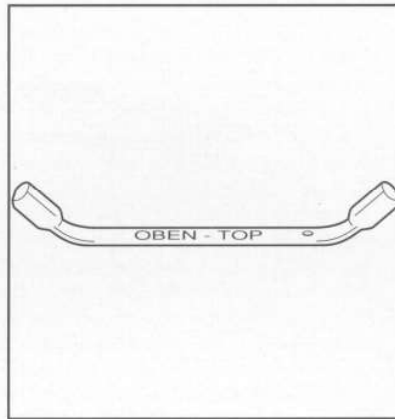
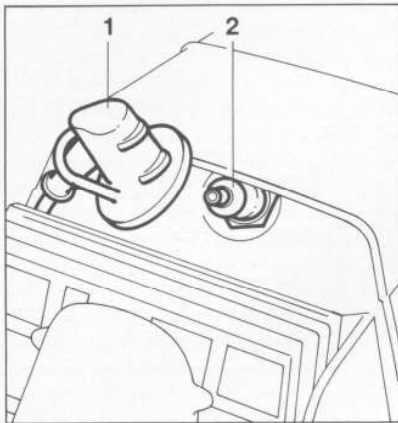

**To remove and disassemble the clutch:**

Troubleshooting chart - see 2.1.

- Remove outer half of air filter - see 11.1.
- Pull terminal off the spark plug and unscrew the spark plug.
- Take out shroud mounting screws and remove the shroud.

- Push the locking strip into the spark plug hole so that "TOP" or "OBEN" is facing upward.

**Important:** To avoid the risk of piston damage, use only the specified locking strip.

- Remove the clutch drum or chain sprocket, see 3.1.

- Unscrew clutch from stub of crankshaft.

**Caution:** Clutch has left-hand thread. Unscrew it clockwise.

Cover washer

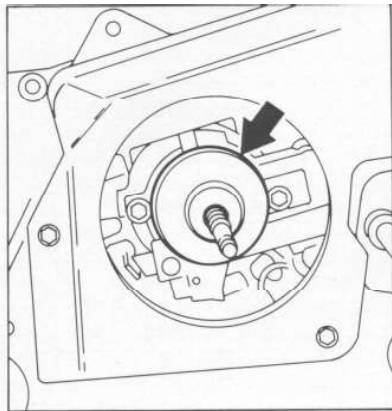

Top:  
Removing a clutch spring

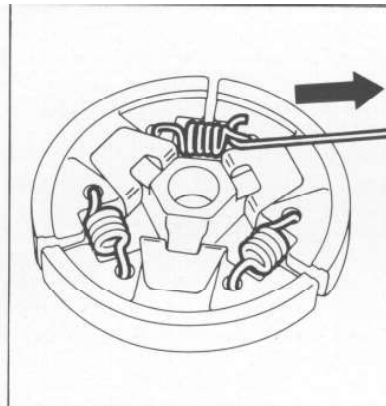

Bottom:  
Component parts of clutch

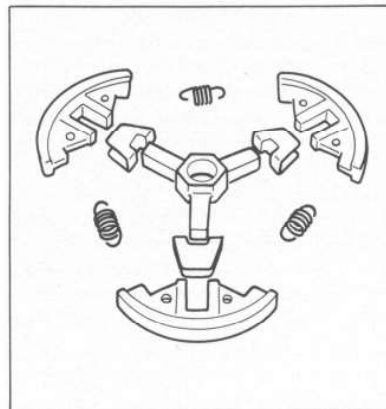

Top:  
Fitting retainer on clutch shoe

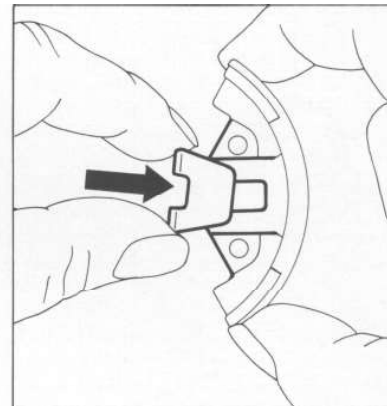

Bottom:  
Pushing clutch shoe onto carrier

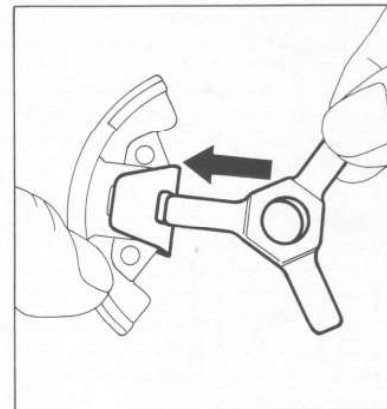

**Note:** A new clutch with cover washer, a modified carrier and different clutch shoe retainers has been installed from machine number X 22 377 760.

**Important:** Always fit identical replacement parts.

- Remove cover washer, if fitted, from stub of crankshaft.

- Use assembly hook to remove all the clutch springs.
- Pull the clutch shoes off the carrier.
- Pull the retainers off the clutch shoes.
- Clean all parts and stub of crankshaft in white spirit. Replace any damaged or worn parts.

- **To reassemble and install the clutch:**
- Push the retainers onto the clutch shoes.
- Fit the clutch shoes over the arms of the clutch carrier so that the series number, e.g. 1122a, is on the same side as the carrier's hexagon.
- Clamp the clutch, e.g. one clutch shoe, in a vise.

3.3 Chain Brake

3.3.1 Disassembly

Top:  
Attaching clutch springs

Bottom:  
Crankshaft stub with neck

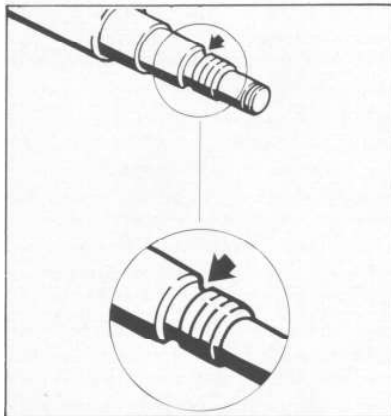
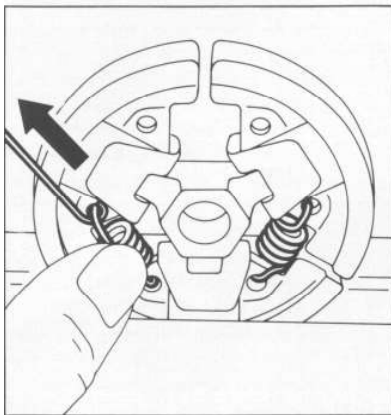

- Attach one end of each spring to the clutch shoes by hand.
- Use the assembly hook to attach the other ends of the springs and press them firmly into the clutch shoes with one finger.
- Fit a cover washer on necked crankshaft stubs. Do not fit a cover on crankshaft stubs without a neck.

Top:  
Crankshaft stub without neck

Bottom:  
Tightening the clutch

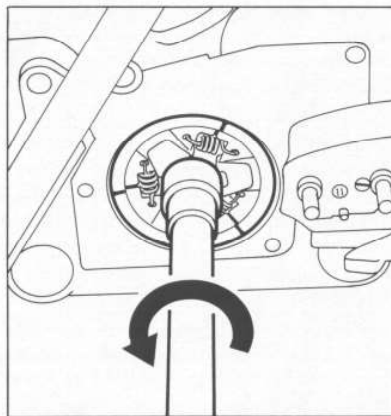
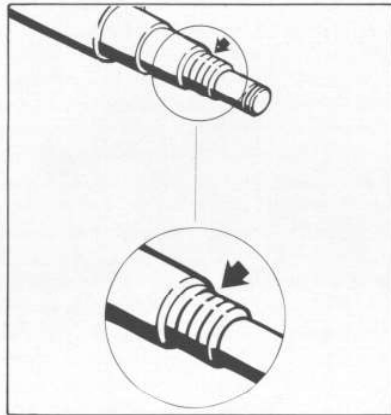

- Screw clutch onto crankshaft and tighten down to a torque of 50 Nm (37 lbf.ft).
- Install clutch drum with rim sprocket (or spur sprocket) - see 3.1.
- Remove locking strip from cylinder. Install spark plug and tighten - down to a torque of 25 Nm (18.5 lbf.ft).
- Fit outer half of air filter.

Top:  
Inner side plate mounting screw

Bottom:  
Cover mounting screws

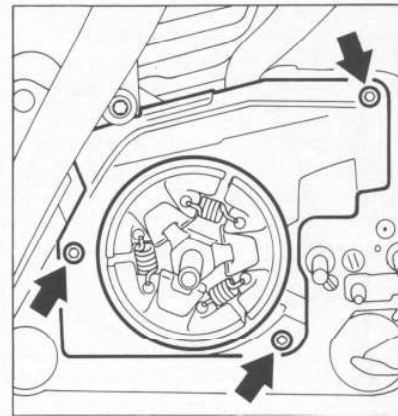
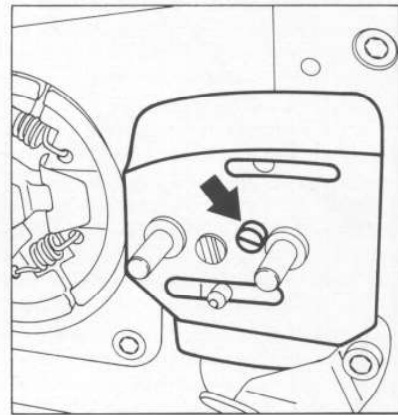

- Remove the clutch drum with rim sprocket (or spur sprocket) - see 3.1
- Remove mounting screw from inner side plate and lift side plate away.
- Remove mounting screws from cover and take out the cover.

Top:  
Detaching brake spring

Bottom:  
Removing brake band

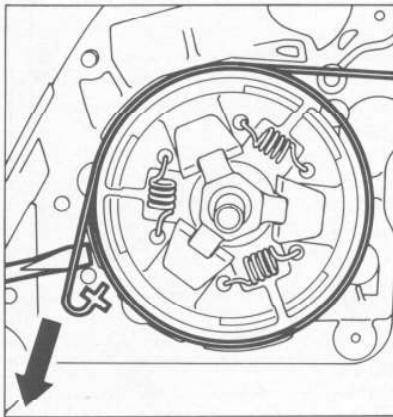
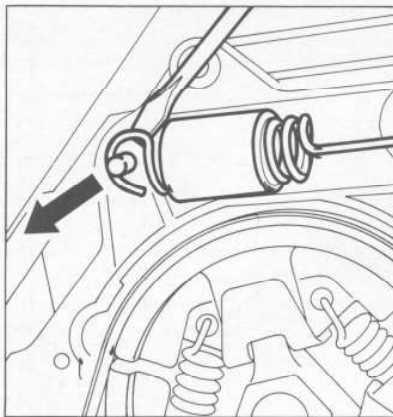

- Carefully pry the brake spring off the anchor pin.
- Pry the brake band out of its seat in the crankcase and detach it from the bell crank.

Top:  
Hand guard mounting screw

Bottom:  
E-clip on bell crank

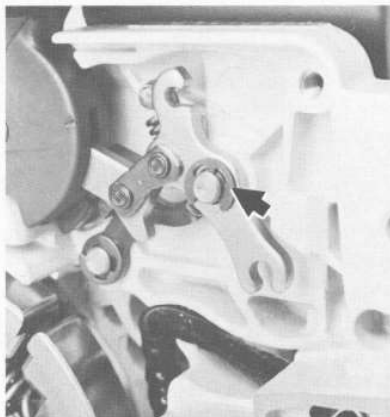

- Take out the hand guard mounting screw.
- Remove E-clip from bell crank pivot pin.
- Pull hand guard with bell crank off the pivot pins.

Top:  
E-clip on cam lever pivot pin

Bottom:  
Detaching spring from pivot pin

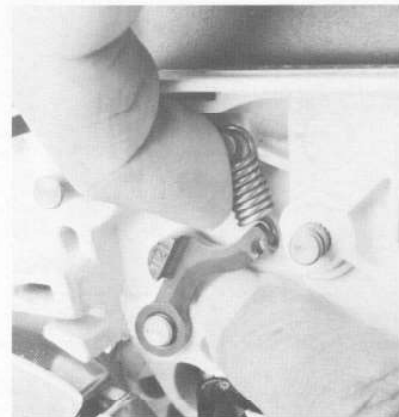
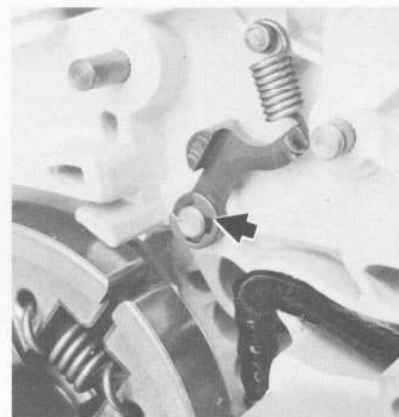

- Remove the E-clip from the cam lever pivot pin.
- Detach spring from cam lever.
- Pull the cam lever off the pivot pin.
- Remove the spring.

3.3.2 Assembly

Driving out brake spring anchor pin

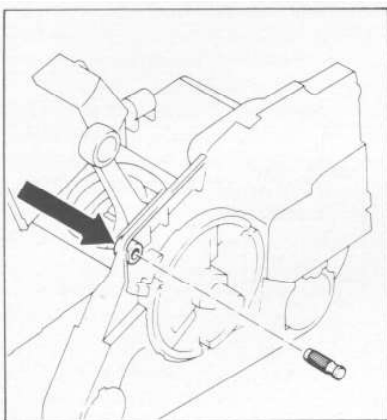

Correctly installed brake spring anchor pin  
a = 4.3 - 4.7 mm (11/64 in)

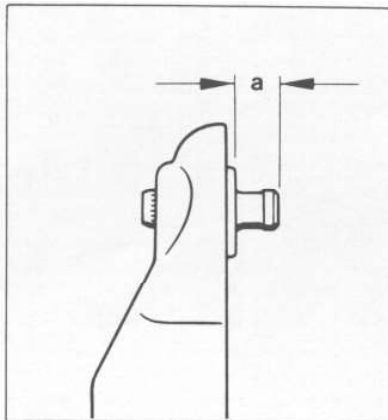

Top:  
1 = Cam lever  
2 = Spring

Bottom:  
Hand guard bearing boss  
with bell crank

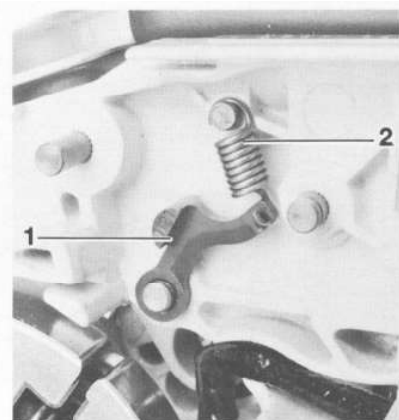

- If it is necessary to replace the brake spring anchor pin, remove the cylinder (see 4.2) and use a suitable punch to drive the anchor pin out of the crankcase in the direction of the arrow (see illustration).

**Note:** Do not drive out the pin in the other direction as this would damage the annular bead which was formed in the crankcase bore when the pin was originally installed. In such a case neither the new anchor pin nor the brake spring would locate properly. Furthermore, the crankcase could be damaged and impair operation of the chain brake.

Inspect condition of all parts. Replace any damaged or worn parts

- If the brake spring anchor pin have been removed, coat the knurled area of the new pin with Loctite, see 12.2, before installation.
- Position the new pin in the bore so that the knurling on the pin meshes with the existing knurling in the bore.
- Carefully tap home the pin squarely to obtain dimension "a" (see illustration).
- Install the cylinder - see 4.3.2.

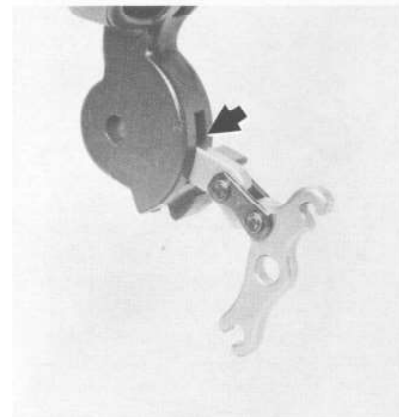

- Fit the cam lever and spring.
- Fit the E-clip.
- Insert bell crank in the side opening of the hand guard bearing boss.

**Note:** Pay attention to correct installed position of bell crank.

Top:  
Pressing cam lever downward

Bottom:  
Correct installed position  
of hand guard

Top:  
Attaching brake band to bell crank

Bottom:  
Fitting brake band in crankcase recess

Top:  
Position of protective tube  
on brake spring  
a = 20 mm (3/4")  
b = 32 mm (1 1/4")

Bottom:  
Attaching brake spring to bell crank

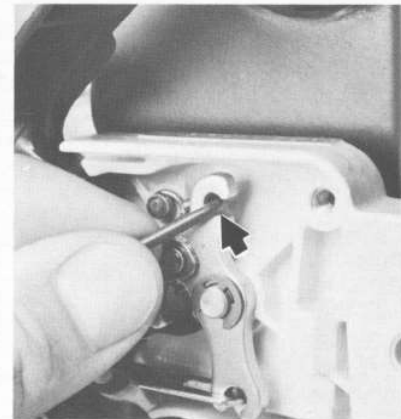
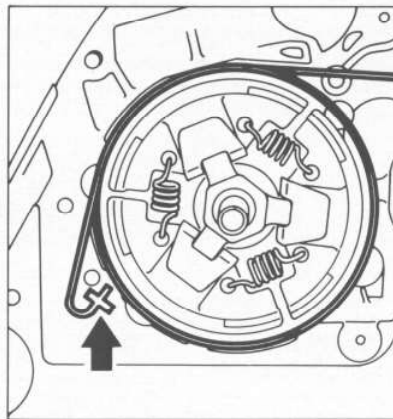
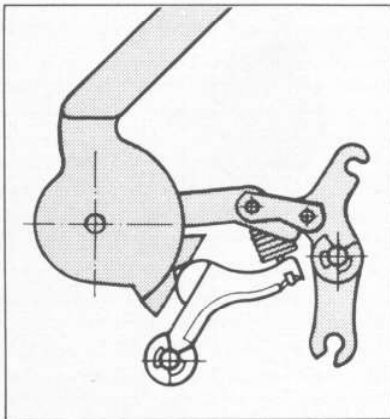
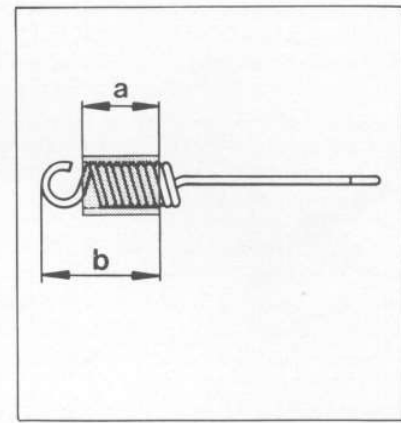
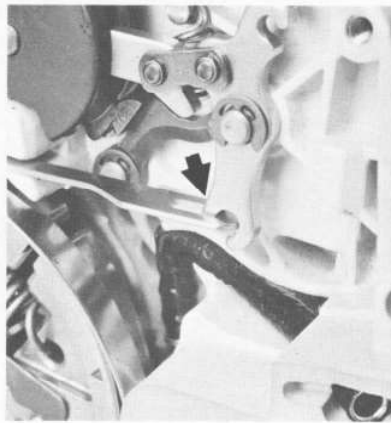
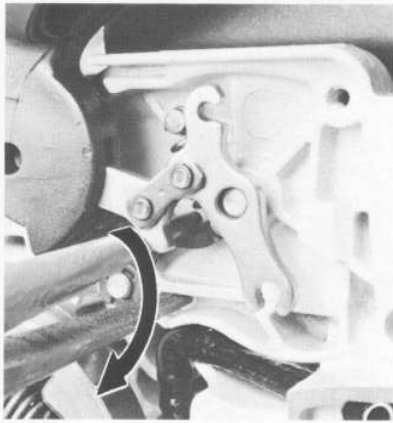

- Position bearing boss of hand guard against the pivot pin and fit the other side of the hand guard over the fan housing.
- Press the cam lever downward and push the hand guard and bell crank onto the pivot pins.
- Secure bell crank with E-clip.
- Fit hand guard mounting screw at fan housing side and tighten to a torque of 3.5 Nm (2.6 lbf.ft).
- Tighten left-hand hand guard mounting screw to 7.0 Nm (5.2 lbf.ft).

- First attach brake band to bell crank and then press it into the crankcase recess.

**Important:** Coat sliding and bearing points with Molykote grease - see 12.2. **Do not** lubricate the brake band.

- Check that protective tube is correctly positioned on the brake spring.
- Hook the brake spring onto the bell crank.

3.4 Chain Tensioner

Top:  
Assembly tool 1117 890 0900

Bottom:  
Attaching brake spring to anchor pin

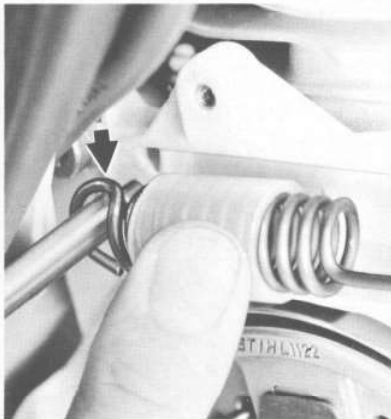
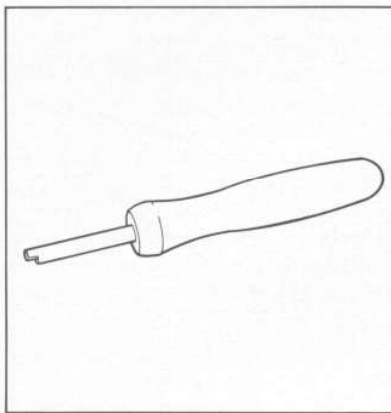

- Use the assembly tool to attach the brake spring to the anchor pin.
- Fit cover over the brake band.
- Fit the inner side plate.
- Install the clutch drum with rim sprocket (or spur sprocket) - see 3.1.

Top:  
Inner side plate mounting screw

Bottom:  
1 = Thrust pad  
2 = Tensioner slide

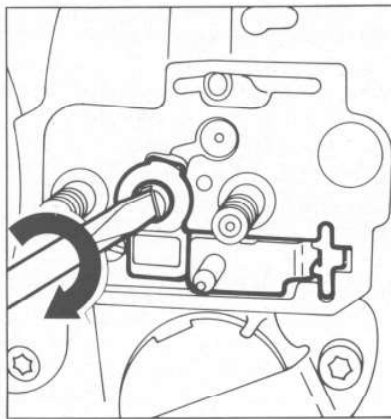
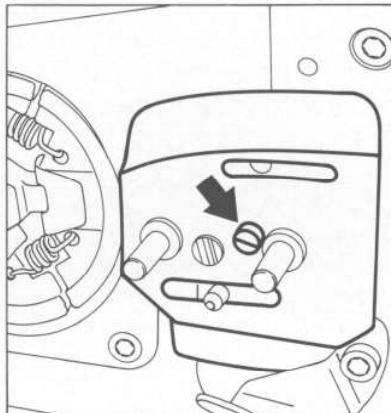

- Remove chain sprocket cover.
- Remove mounting screw from inner side plate and lift side plate away.
- Use a screwdriver to turn spur gear clockwise until tensioner slide is at the extreme right against the thrust pad.

Top:  
1 = Retainer  
2 = Mounting screw

Bottom:  
1 = Spur gear  
2 = Cover plate

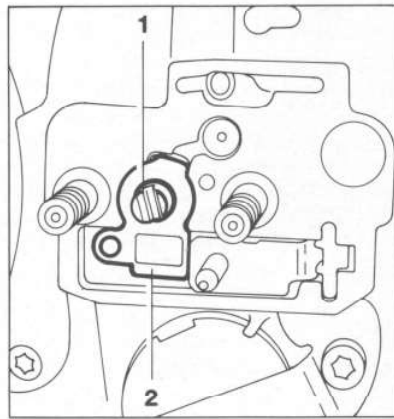
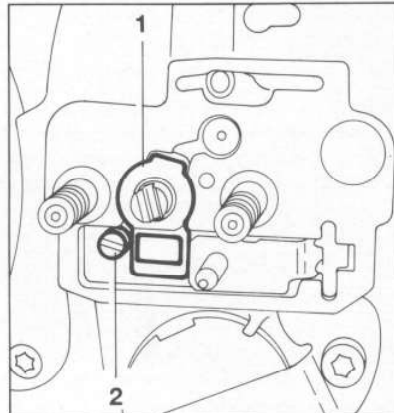

- Pull out the retainer.
- Remove the cover plate mounting screw.
- Pull the cover plate off the spur gear.
- Pull out the spur gear.

3.5 Bar mounting studs

Top:  
Removing tensioner slide with  
adjusting screw and thrust pad

Bottom:  
1 = Thrust pad  
2 = Tensioner slide  
3 = Adjusting screw

O-ring in spur gear

Top:  
Stud puller 5910 893 0501

Bottom:  
Unscrew collar stud

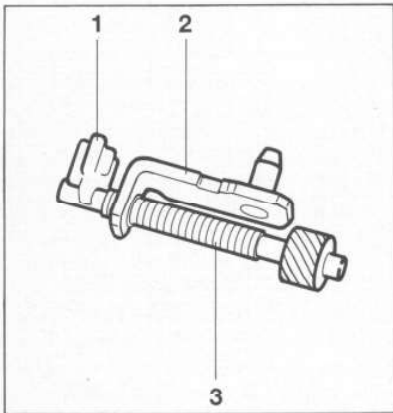
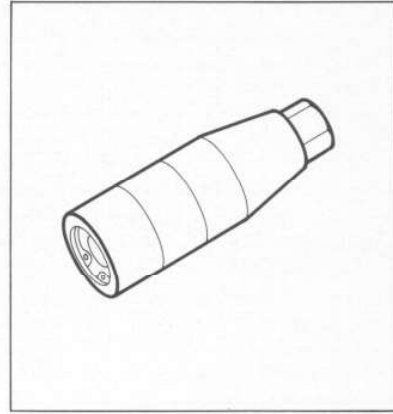
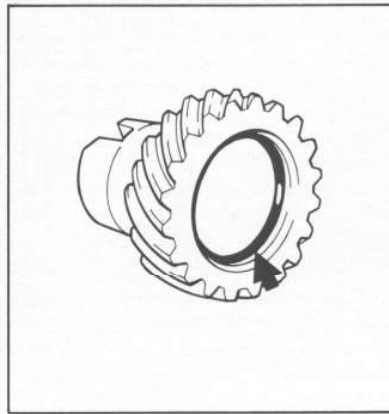
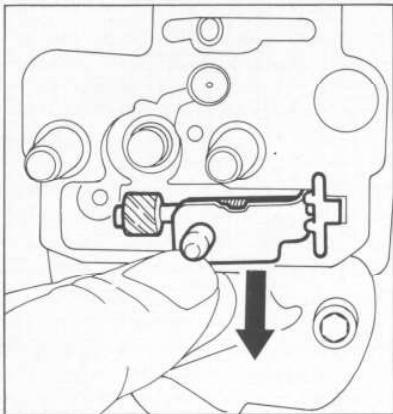

Reverse the above sequence to install  
the chain tensioner.

**Note:** Coat teeth of adjusting screw and  
spur gear with grease, see 12.2, before  
refitting. Check that O-ring is fitted in  
spur gear and lubricate it with a little oil  
before installing the spur gear.

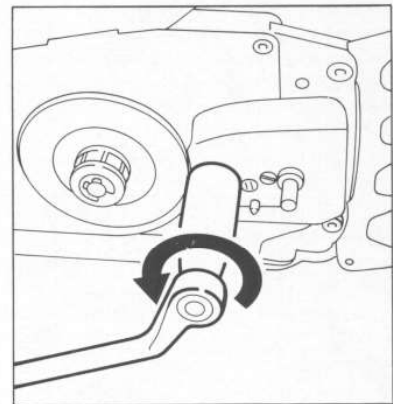

- Take out the tensioner slide with adjusting screw and thrust pad.
- Inspect the teeth on the spur gear and adjusting screw. If the teeth are damaged, pull off the thrust pad, take the adjusting screw out of the tensioner slide and replace both parts.

- Remove the sprocket cover.
- Push the stud puller over each collar stud as far as it will go. Use a 15 mm wrench to unscrew the collar studs counterclockwise.
- Coat thread of collar stud with Loctite, see 12.2. Fit collar stud and tighten it down to 15 Nm (11.0 lbf.ft).

4. ENGINE

4.1 Removing and Refitting Exhaust Muffler

Top:  
Upper casing mounting screws

Bottom:  
Lower casing mounting screws

Top:  
Removing exhaust gasket

Bottom:  
1 = Retaining tabs  
2 = Spark arrestor screen

1 = New muffler  
2 = Gasket  
3 = Flange  
4 = Gasket  
5 = Cylinder (original version)

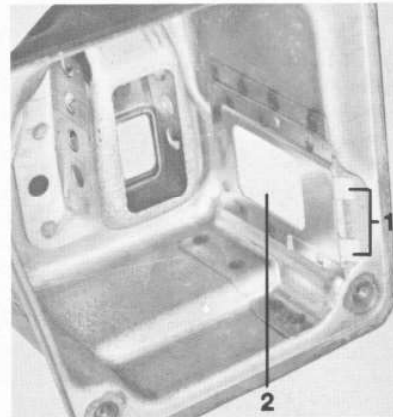
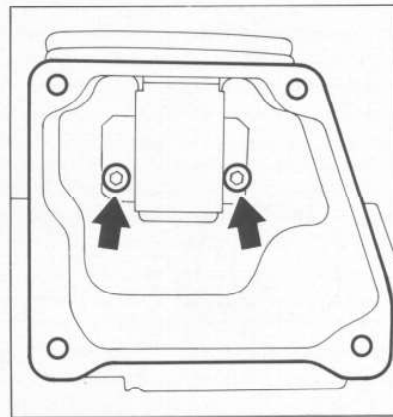
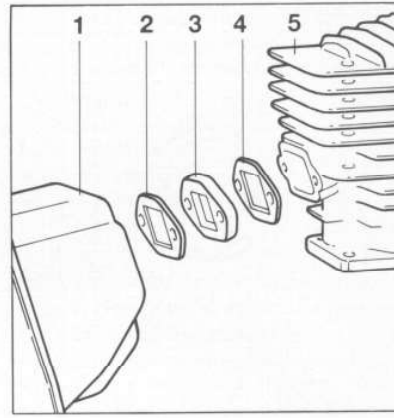
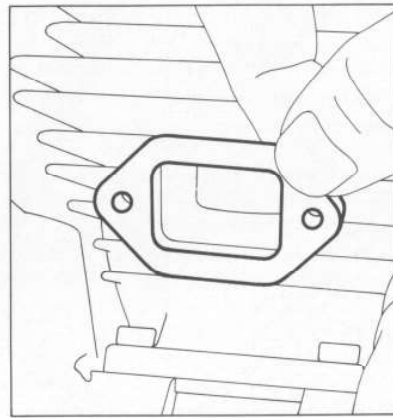
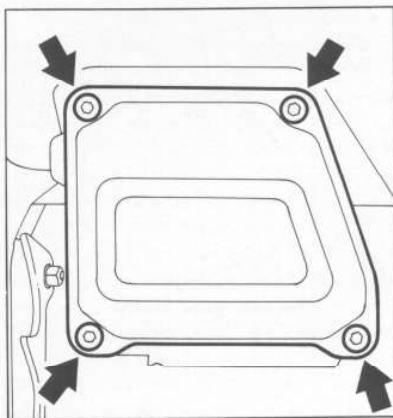

Reassemble in the reverse sequence.

**Important:** A modified cylinder (with extended exhaust flange) is installed from machine number X 18 760 750. A gasket and flange are required to fit a new muffler on an original-type cylinder.

Only the new version of the muffler may be fitted to the new cylinder.

**Note:** Fit a new exhaust gasket. Coat threads of screws with Loctite, see 12.2. Tighten screws of original-type lower casing to 10 Nm (7.5 lbf.ft) and screws of new version to 15 Nm (11.0 lbf.ft). Tighten screws of upper casing to 8 Nm (5.9 lbf.ft).

Troubleshooting chart - see 2.2.

- Take out the upper casing mounting screws and remove upper casing.
- Take out the lower casing mounting screws and remove lower casing.

- Remove the gasket and flange, if fitted.
- Inspect the spark arrestor screen, if fitted. If necessary, bend back the retaining tabs and pull out the screen.
- Clean the spark arrestor screen or fit a new one.

4.2 Exposing the Cylinder

1 = Washer  
2 = Sleeve

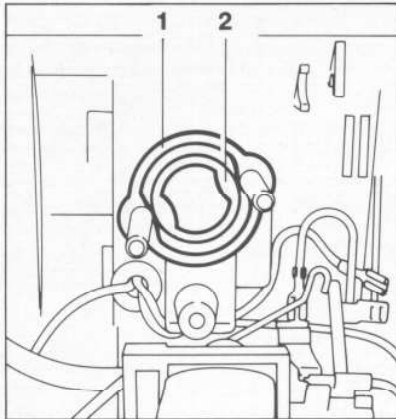

Always check and, if necessary, repair the fuel system, carburetor, air filter and ignition system before looking for faults on the engine.

- Troubleshooting chart - see 2.2.
- Drain the fuel and oil tanks.
- Remove the shroud - see 3.2.
- Unscrew the spark plug.
- Remove the muffler - see 4.1.
- Remove the carburetor - see 11.3.
- Pull the washer off the studs and remove the sleeve from the manifold.

**Note:** The previous backing plate and gasket were replaced by the washer and sleeve from machine number X 20 742 548.

Reassemble in the reverse sequence.

4.3 Cylinder and Piston

4.3.1 Removal

Top:  
Throughholes to cylinder base screws

Bottom:  
Removing cylinder and pushing manifold out of tank housing

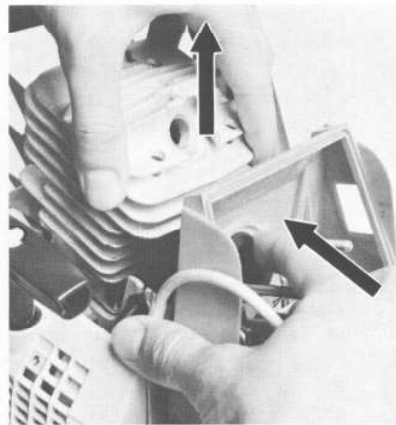
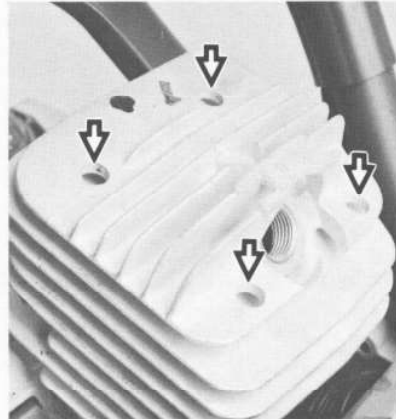

- Release and unscrew the cylinder base screws.
- Pull the cylinder off the piston and, at the same time, push the manifold through the tank housing opening.

**Caution:** Do not use pointed or sharp-edged tools for this job.

- Remove the cylinder gasket.

Top:  
Removing cylinder gasket

Bottom:  
1 = Hose clamp  
2 = Manifold

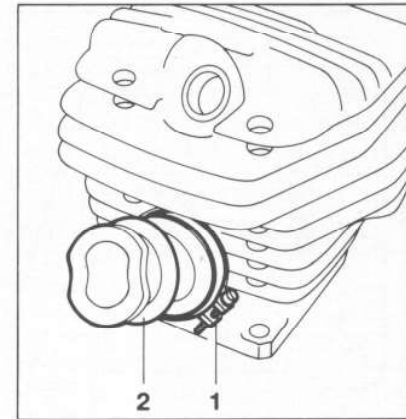
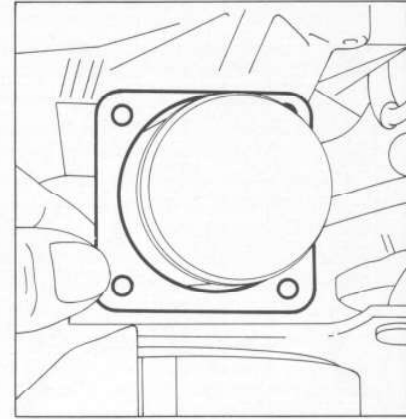

- Release the hose clamp on the manifold. Pull the manifold off the intake port.

- Inspect the cylinder and replace it if necessary.

**Note:** If a new cylinder has to be installed, always fit the matching piston. Replacement cylinders are only supplied complete with piston for this reason. If a new piston is needed, only fit the special replacement piston.

4.3.2 Installation

Top:  
Removing snap ring

Bottom:  
Assembly drift 1110 893 4700

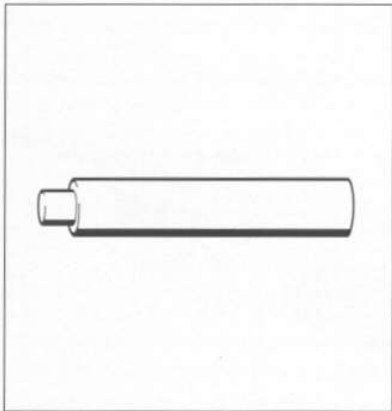
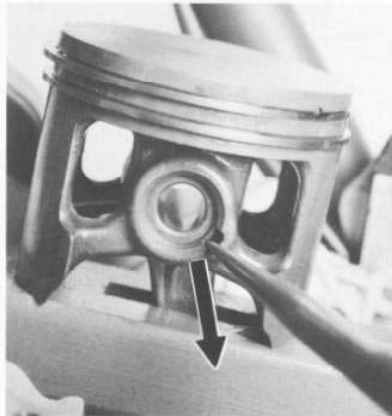

Top:  
Pushing out piston pin

Bottom:  
Piston rings



Top:  
Fitting needle cage

Bottom:  
Arrow on piston head points toward muffler

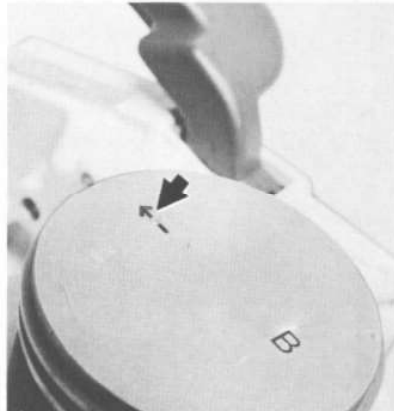
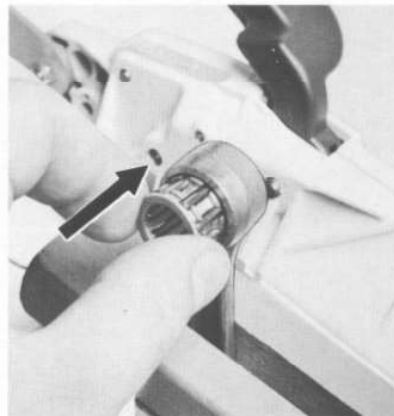

**Important:** Before removing the piston, decide whether or not the crankshaft has to be removed as well. To remove the flywheel and clutch, block the crankshaft by sliding the wooden assembly block between the piston and crankcase.

- Use a scriber or similar tool to ease the hookless snap rings out of the grooves in the piston bosses.

- Now use the assembly drift to push the piston pin out of the piston. If the piston pin is stuck, tap the end of the drift **lightly** with a hammer if necessary. **Important:** Hold the piston steady during this process to ensure that no jolts are transmitted to the connecting rod. Remove the piston and take the needle cage out of the connecting rod.

- Inspect piston rings and replace if necessary - see 4.4.

- Thoroughly clean the gasket seating surface on the cylinder. Lubricate the needle cage with oil and fit it in the small end.

- Heat the piston on an electric heating plate to approx. 60 °C (140 °F) and slip it over the connecting rod so that the arrow on the piston head points toward the exhaust muffler.

Top:  
Assembly drift pushed through  
piston and small end

Bottom:  
Installing the piston pin

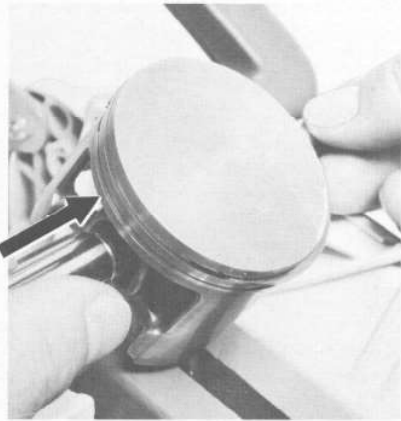

- Push the assembly drift, small diameter first, through the piston and small end (needle cage) from the clutch side and line up the piston.
- Fit the piston pin on the small diameter of the assembly drift and slide it into the piston.

**Note:** Move the piston back and forth to ease insertion.

Top:  
Correct position of gap in snap ring

Bottom:  
Installing tool 5910 890 2212  
1 = Magnet  
2 = Sleeve

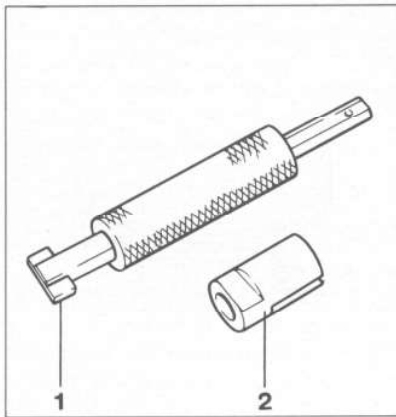
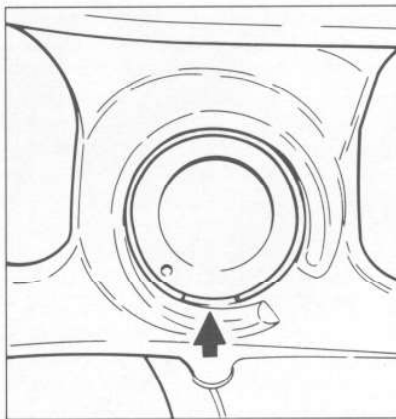

- Fit snap ring so that its gap is on the piston's vertical axis (it must point either up or down).

**Note:** Fit snap ring with the special installing tool.

Use the installing tool as follows:

- Remove the sleeve from the tool.

Top:  
Snap ring attached to magnet  
with ring gap at flat side of the  
tool's shank

Bottom:  
Pushing sleeve over the magnet;  
pin at flat side of tool's shank

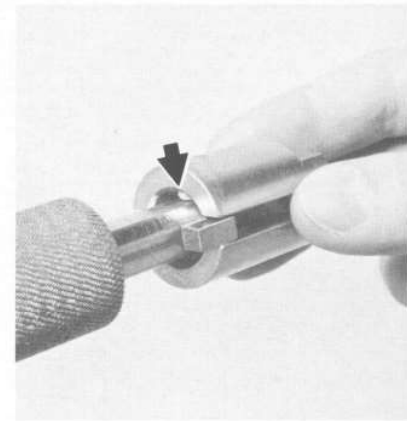
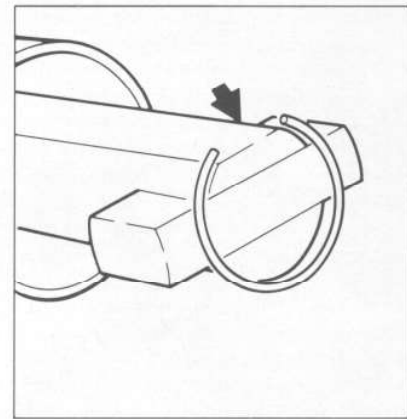

- Attach the snap ring to the magnet so that the snap ring gap is on the flat side of the tool's shank (see illustration).
- Push the large slotted diameter of the sleeve over the magnet and snap ring.

Top:  
Pressing installing tool vertically downwards until the sleeve butts against the tool's shoulder.

Bottom:  
Slipping sleeve onto other end of shank

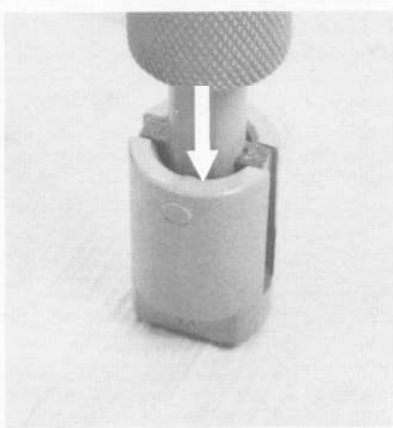

Top:  
Inserting snap ring in piston boss

Bottom:  
Wooden assembly block  
1108 893 4800

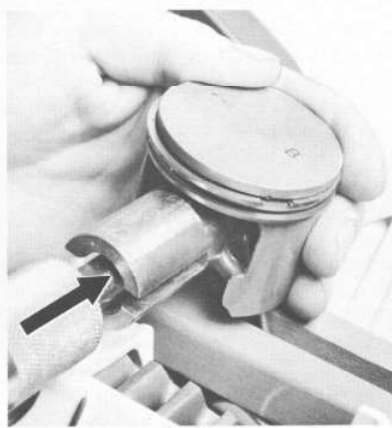

Top:  
Piston resting on wooden assembly block

Bottom:  
1 = Original manifold  
2 = New manifold

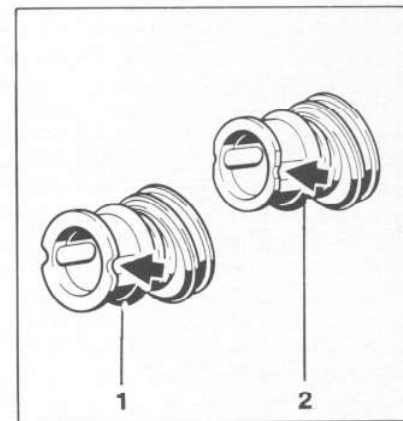
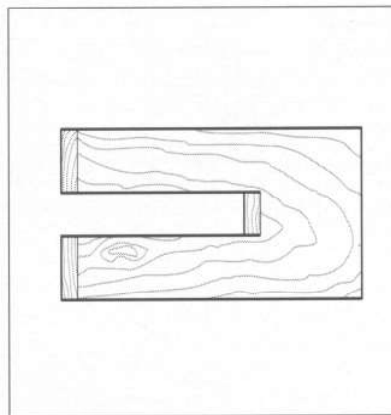
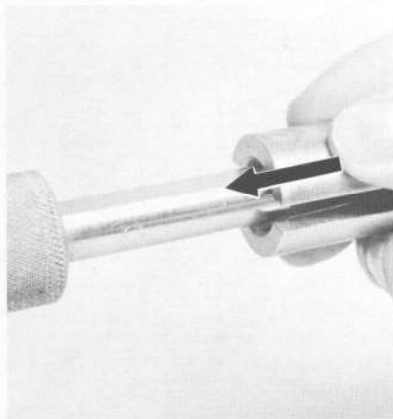
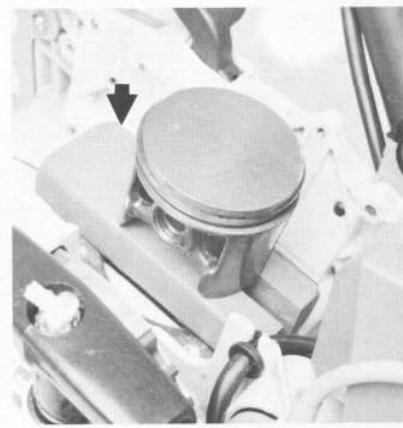

**Note:** Position the sleeve so that the inner pin points toward flat face of tool's shank.

- Stand the installing tool, sleeve downward, on a flat surface (wooden board) and press vertically downwards until the sleeve butts against the tool's shoulder.
- Remove the sleeve and slip it onto the other end of the shank.

**Note:** Inner pin must again point toward flat face of tool's shank.

- Apply the installing tool to the piston boss (flat face on shank must point toward piston head), hold the piston steady, center the tool shank exactly and press home until the snap ring slips into the groove.
- Fit new cylinder gasket on the crankcase.
- Lubricate piston and piston rings with oil.

- Slide wooden assembly block between piston and crankcase.

- Rest the piston on the wooden assembly block.

**Note:** It is necessary to fit the original manifold on machines with the original backing plate (seal between carburetor and manifold). The new washer and sleeve must be fitted with the new manifold - see 4.2.

Top:  
Correct position of manifold

Bottom:  
Correct position of hose clamp  
a = 7 - 7.5 mm (approx. 9/32")  
b = approx. 45°

Top:  
Fixing pins in piston and correct  
position of piston rings

Bottom:  
Clamping strap 0000 893 2600

Top:  
Compressing piston rings with  
the clamping strap

Bottom:  
Fitting cylinder over the piston

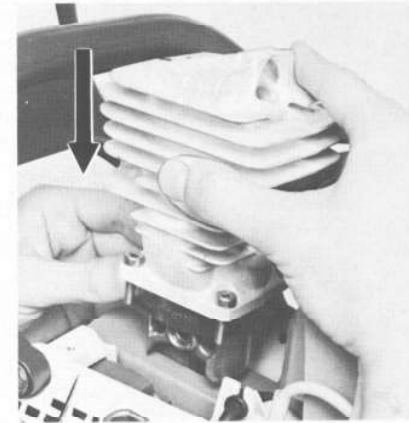
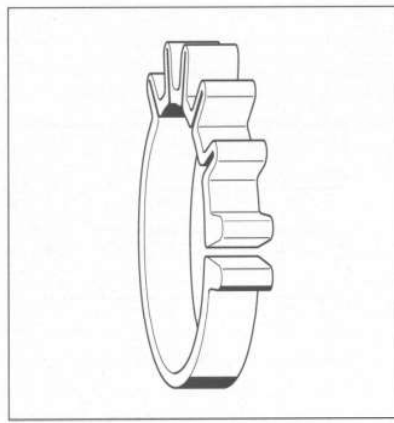
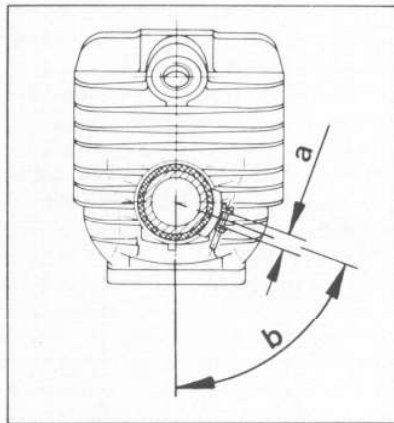
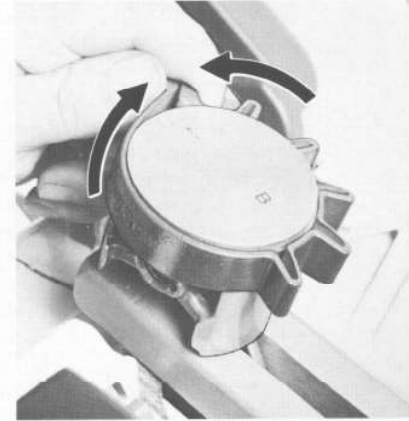
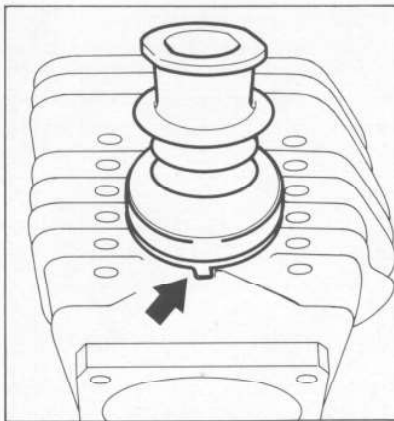

- Push the manifold onto the intake port so that its tab lines up with the rib on the cylinder (see illustration).
- Slide the hose clamp onto the manifold. The screw head must point to the right.
- Tighten the hose clamp so that its ends point to the right at an angle of approx. 45° (looking at intake port). Continue tightening the screw until the gap between the two ends of the hose clamp is 7 - 7.5 mm (approx. 9/32").

- Note:** If a new cylinder with a long exhaust port is installed, also replace the old muffler - see 4.1.
- Position the piston rings so that the radii at the ring gap meet at the fixing pin in the piston groove when the rings are compressed.

- Use the clamping strap to compress the piston rings around the piston.
- Lubricate the inside of the cylinder with oil and line it up so that it is roughly positioned as it will be in the installed condition.
- Now slide the cylinder over the piston - the clamping strap is pushed downward as the piston rings slip into the cylinder.
- Remove clamping strap and wooden assembly block.

4.4 Piston Rings

Top:  
Pressing the manifold downward

Bottom:  
Pulling manifold through intake opening  
in tank housing

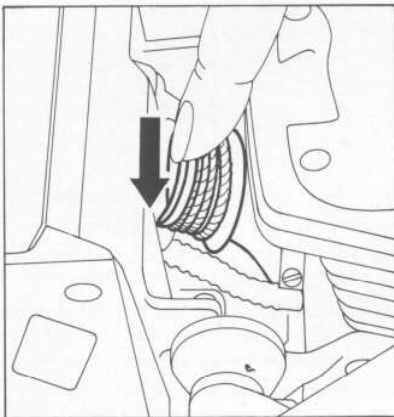

Tightening the cylinder base screws  
with torque wrench 5910 890 0310

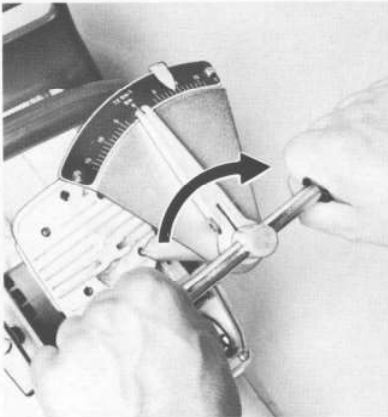

- Carefully line up the cylinder and gasket.
- Fit new cylinder base screws of property class 12.9 and tighten them down alternately in a diagonal pattern.

**Note:** Tighten M5 x 20 screws to 12 Nm (8.8 lbf.ft) and M6 x 20 screws to 15 Nm (11.0 lbf.ft)

**Important:** It is essential to observe the above tightening torques as the screws might otherwise work loose.

Top:  
Piston ring grooves

Bottom:  
Fitting piston ring

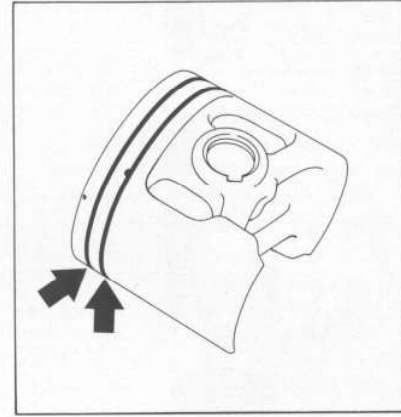

- Fit the manifold in the tank housing intake opening as follows:  
Wind a piece of string (about 15 cm / 6" long) around the back of the manifold flange, then press the manifold downward and pass the ends of the string through the intake opening.
- Pull the ends of the string outward. The manifold flange is thus pulled through the tank housing intake opening without damaging the manifold.

Assembly is now a reversal of the disassembly sequence. Always fit new gaskets as a matter of routine.

- Remove the piston - see 4.3.1.
- Remove rings from piston.
- Use a piece of an old piston ring to scrape the grooves clean.
- Install the new piston rings in the grooves so that the radii face upward.
- Install the piston - see 4.3.2.

4.5 Crankcase

4.5.1 Removing the Crankshaft

Driving out a dowel pin

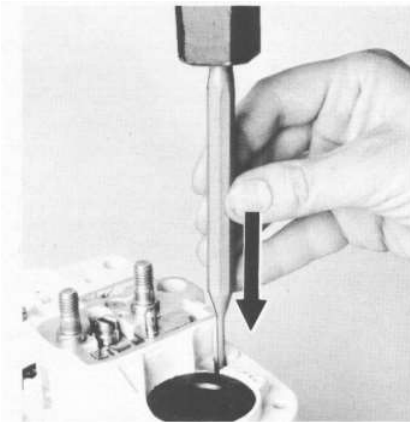

Top:  
Crankcase mounting screws

Bottom:  
Rotating spur gear clockwise

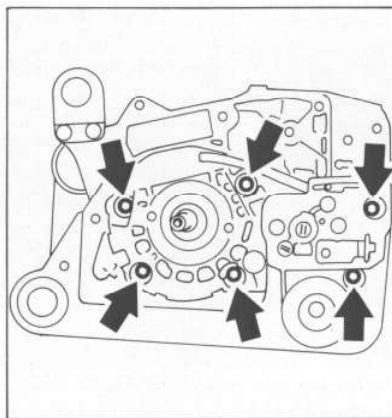

Top:  
Service tool AS 5910 890 2205

Bottom:  
Service tool ZS 5910 890 2220

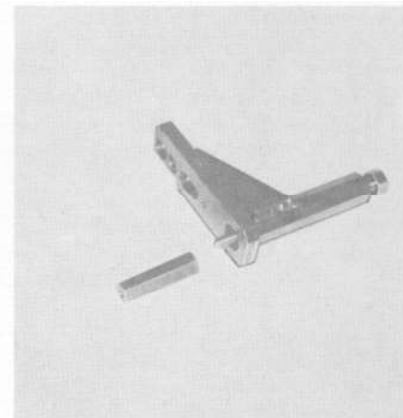

- Remove chain brake - see 3.3.1.
- Remove the oil pump - see 10.4.
- Remove the flywheel - see 5.1.5.
- Remove the ignition module - see 5.1.6.
- On machines with heated handles, remove the generator - see 9.5.
- Remove the cylinder and piston - see 4.3.1.
- Remove the tank housing - see 11.10.

- Dowel pin at chain tensioner side: First remove plug from other side of crankcase and then use a suitable tool, e.g. 5 mm (3/16") drift, to drive the dowel pin out of the two halves of the crankcase.

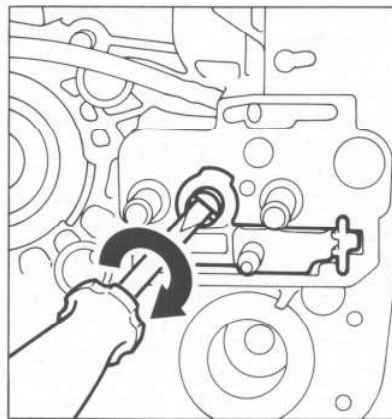

- Unscrew the six mounting screws which join the two halves of the crankcase.
- Use a screwdriver to rotate spur gear clockwise until the tensioner slide butts against the thrust pad.
- Pull the heat shield (foil) off the crankcase.

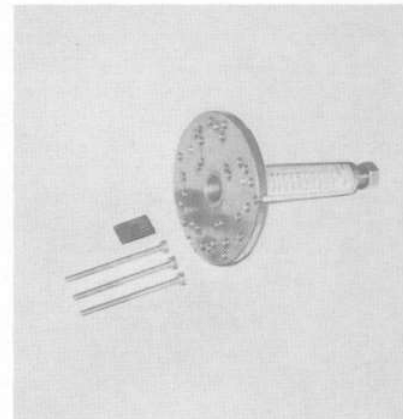

**Note:** Use service tools AS and ZS to remove the crankshaft. Follow the instructions supplied with the tool.

- Back off spindle of service tool AS all the way.
- Slip service tool AS over the two collar studs, fit the hexagon nuts (for sprocket cover) and tighten them down by hand.

Top:  
Service tool AS mounted in position

Bottom:  
Pressing crankshaft out of bearing  
seat at clutch side

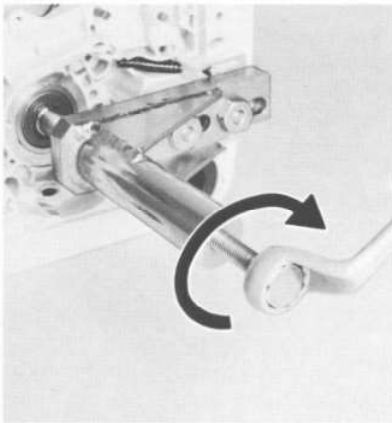
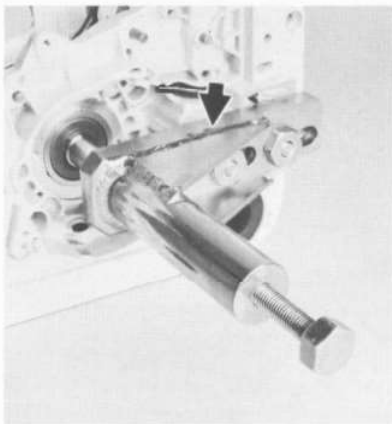

- Use a 19 mm wrench to turn the spindle clockwise until the crank shaft is pressed out of the ball bearing. The two halves of the crankcase separate during this process.

Thrust sleeve 1107 894 1000 of clutch  
puller 1107 890 4500 fitted in position

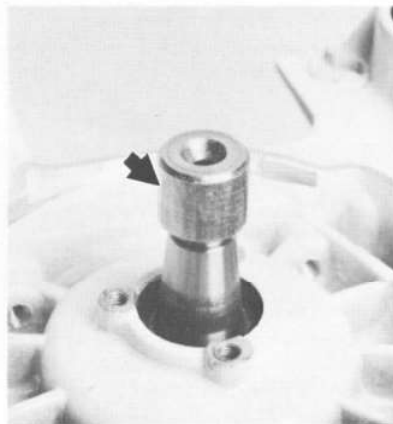

**Note:** Fit the thrust sleeve to protect the crankshaft thread during the following removal operation.

- Fit service tool ZS against the outside of the crankcase (ignition side).
- Back off the spindle by turning it clockwise until the tool's drilled plate locates flat against the crankcase.
- With the crankcase horizontal (cylinder flange upward), rotate service tool until the number 11 on plate points downward.
- Secure the service tool to the crankcase with the three M5x72 mounting screws. Insert the screws in the holes marked "11" and tighten them down against the drilled plate.

Top:  
Service tool ZS mounted in position,  
"11" points down

Bottom:  
Pressing crankshaft out of bearing  
seat at ignition side

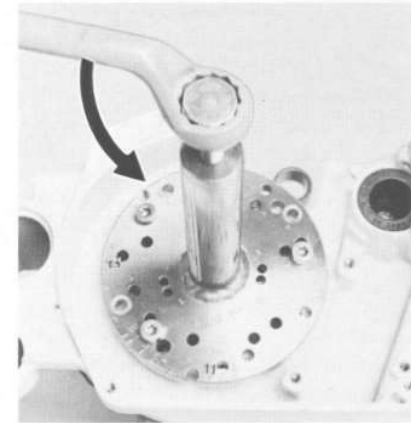
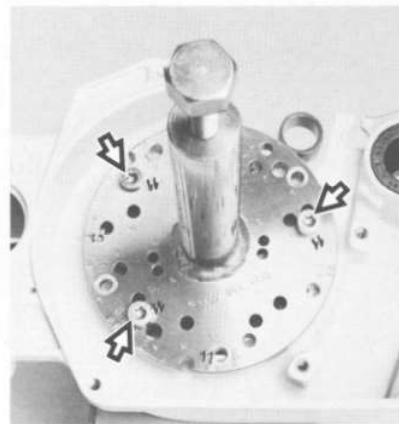

- Turn spindle counterclockwise until it locates against the crankshaft.
- Use a 19 mm wrench to continue turning the spindle and thus push the crankshaft out of its bearing seat at the ignition side.

Top:  
1 = Crankshaft  
2 = Connecting rod

Bottom:  
Prying out oil seal at clutch side

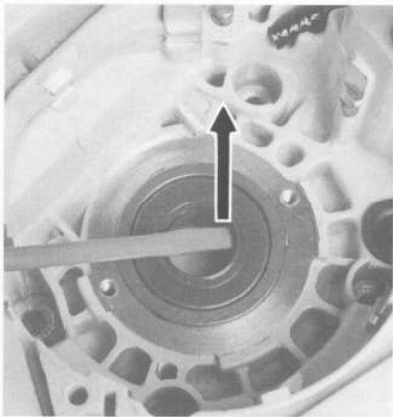
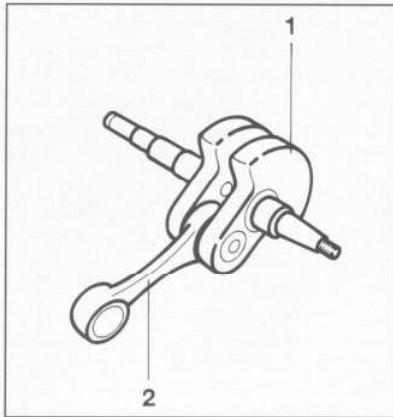

- The crankshaft, connecting rod and needle bearing form an inseparable unit. This means that the crankshaft must always be replaced as a complete unit in the event of damage to any one of these parts. When fitting a replacement crankshaft always install new oil seals and ball bearings.
- Remove the gasket from the crankcase sealing face.
- Pry the oil seal out of the ball bearing at the clutch side.

Top:  
Pressing out ball bearing at clutch side with press arbor 1119 893 7200

Bottom:  
Knocking out oil seal at ignition side

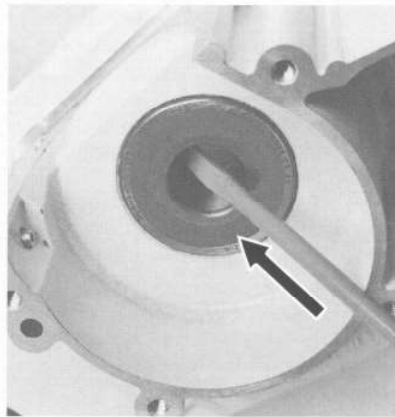
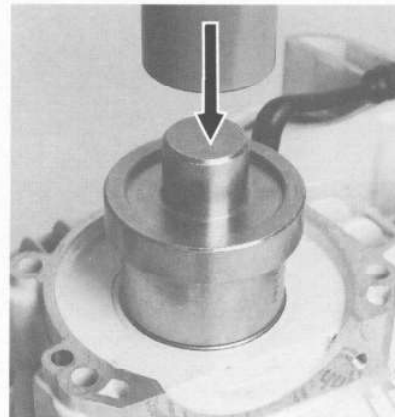

- Use press arbor to press the ball bearing out of its seat.
- Use a screwdriver or similar tool to knock the oil seal out of its seat at the ignition side.
- From inside the crankcase, use arbor 1122 893 7200 to press the ball bearing out of its seat.

Pressing out ball bearing at ignition side with arbor 1122 893 7200

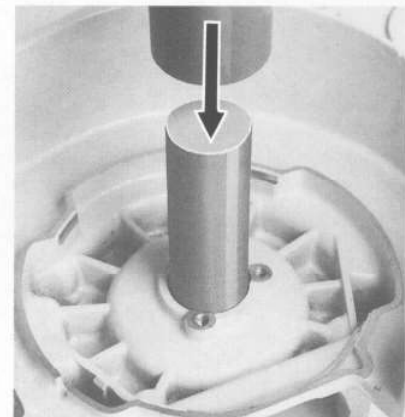

- Pull the oil pickup hose out of bore in crankcase.
- Inspect the two halves of the crankcase for cracks and replace if necessary.

**Note:** The crankcase must be replaced as a complete unit even if only one half is damaged.

All other parts which are still serviceable can then be transferred to the new crankcase after the new bearings have been fitted, i.e. the crankcase has to be heated for this purpose.

**Note:** Use the stud puller to remove and install the bar mounting studs - see 3.5.

### 4.5.2 Installing the Crankshaft

Top  
Crankcase in correct assembly sequence

Bottom:  
Dowel pin

Bottom:  
Bottom:  
Plastic plug

Top:  
Oil ump fitted in position

Ball bearing in position  
(flat side facing upward)

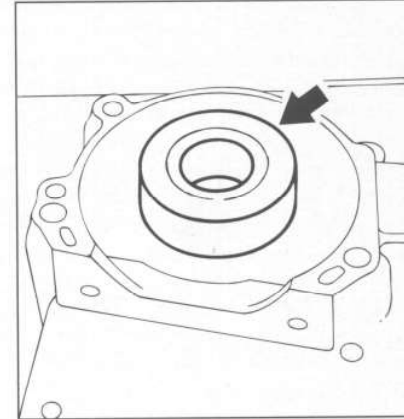
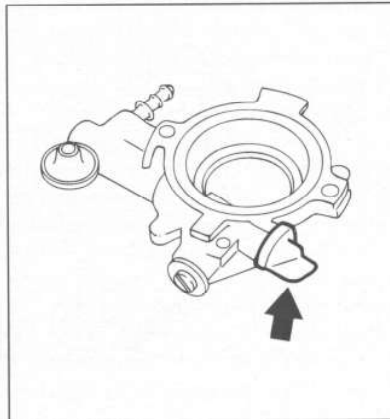
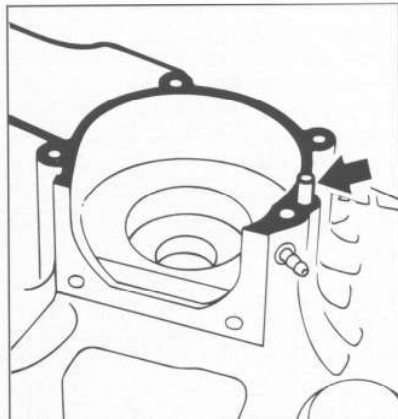
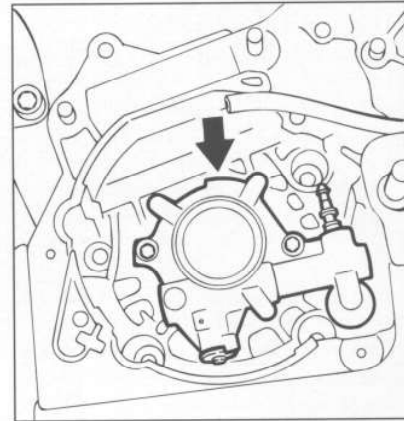
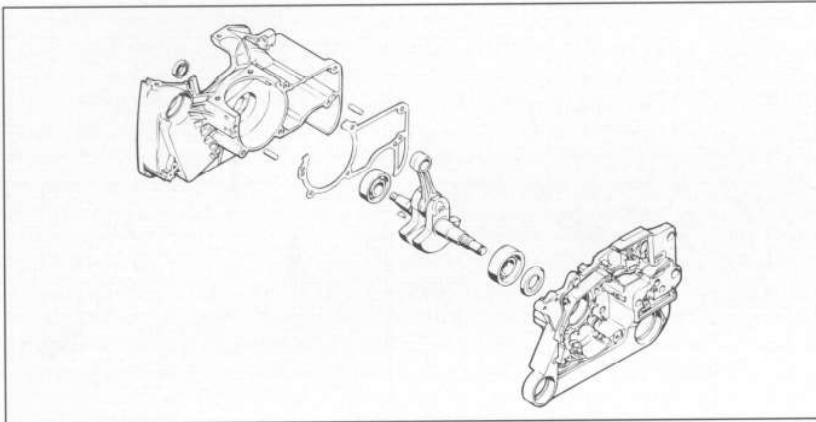

If the original crankcase is used again, remove the gasket residue and clean the mating surfaces - they must be cleaned very thoroughly to ensure a perfect seal.

**Note:** If you install a new crankcase, stamp the machine number on the crankcase with 2.5 mm (0.1") figure stamps.

- Check that dowel pin is in position or fit it in the new crankcase.

- Pull the plastic plug out of the oil pump.

- Position the oil pump against the crankcase. Fit and tighten down the mounting screws.

**Note:** Before heating the crankcase, remove all rubber and plastic components, such as oil pickup and delivery hoses, grommets, annular buffers and levers - see 7.1 and 10.2. Check condition of all parts and replace as necessary.

- Heat area of bearing seat on clutch side of crankcase to approx. 120 °C (250 °F).  
- Place ball bearing with wider outer race in position so that its flat side points upward and then press it in until it locates against the oil pump.

**Note:** The ball bearing can be fitted by hand if the crankcase is heated as specified. However, this operation must be carried out very quickly because the bearing absorbs heat immediately and begins to expand.

Top:  
Pressing in ball bearing with arbor  
1119 893 7200

Bottom:  
Fitting annular buffer  
1 = Groove

Top:  
Annular buffer mounting screws

Bottom:  
Fitting oil pickup hose

Top:  
Correctly fitted oil pickup hose

Bottom:  
1 = Lever  
2 = Spring  
3 = Chain tensioner

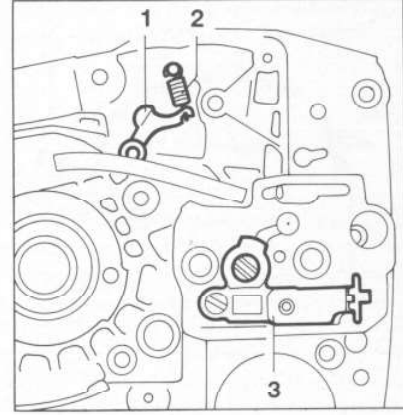
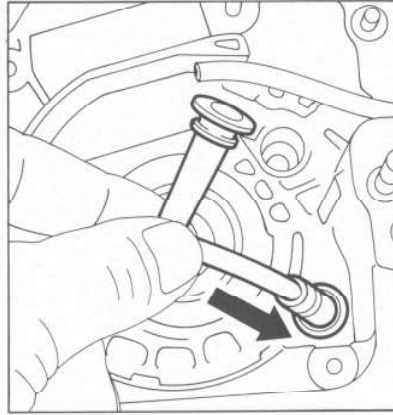
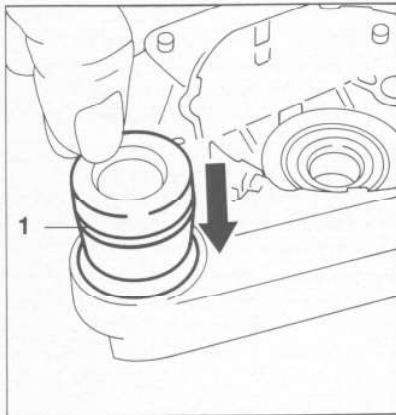
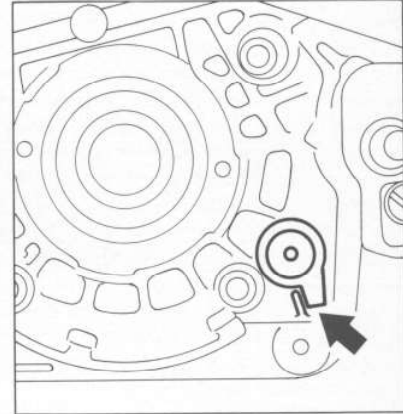
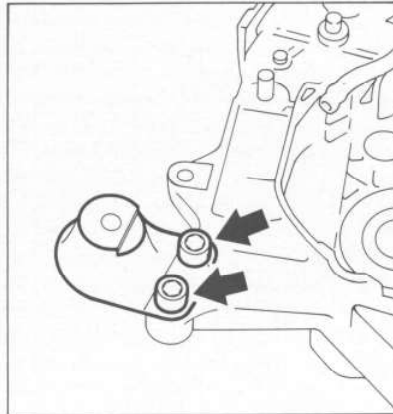
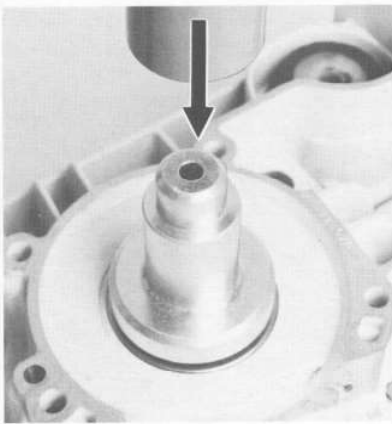

- If no facilities for heating the crankcase are available, use the press arbor to install the ball bearing.
- Remove the oil pump and refit the plastic plug.
- Push the two annular buffers (tapered side first) into position until their annular grooves engage the inner rib.

- Place the annular buffer in position - the tapered side must face outward. Fit the mounting screws and tighten them to 9 Nm (6.6 lbf.ft).
- Push the oil pickup hose through the crankcase bore.

- Use a blunt tool to push the oil pickup hose into the bore so that the tab locates in its seat at the bottom right (see illustration).
- Fit the lever over the pivot pin and secure it with the E-clip.
- Attach the spring.
- Install the chain tensioner, see 3.4, and move tensioner slide up against right-hand stop.

Ball bearing in position

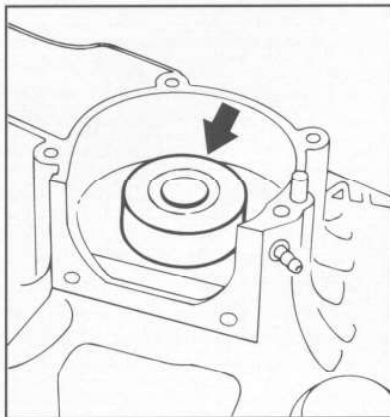

Top:  
Pressing in ball bearing with arbor  
1119 893 7200

Bottom:  
Fitting annular buffer in ignition side  
of crankcase  
1 = Groove

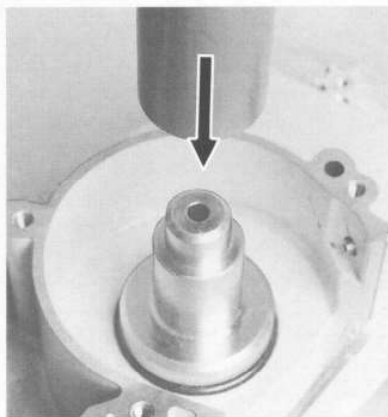

Top:  
1 = mounting screw  
2 = Annular buffer

Bottom:  
Threaded sleeve 5910 893 2420 fitted  
on spindle of service tool ZS

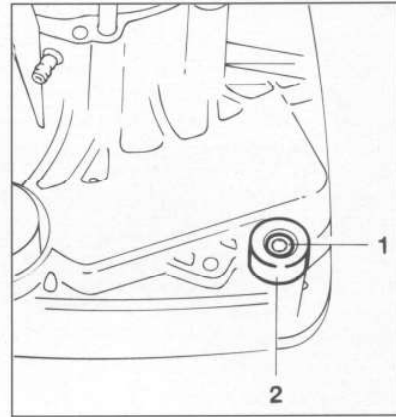

- Heat area of bearing seat on ignition side of crankcase to approx. 120 °C (250 °F).
- Press ball bearing fully home as far as stop. The open side of the bearing must face upward.

**Important:** The ball bearing is closed at one side. The open side must be on the inside of the crankcase to guarantee proper lubrication.

**Note:** The ball bearing can be fitted by hand if the crankcase is heated as specified. However, this operation must be carried out very quickly because the bearing absorbs heat immediately and begins to expand.

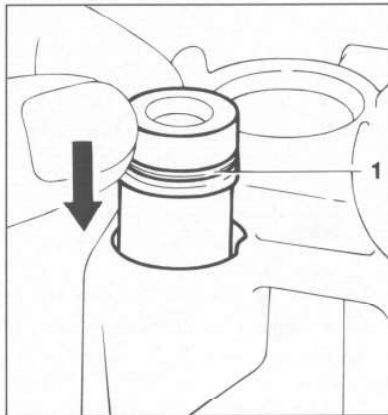

If no facilities for heating the crankcase are available, use the press arbor to install the ball bearing.

- Push both annular buffers into the crankcase bores, from the outside, until their annular grooves engage the inner rib.

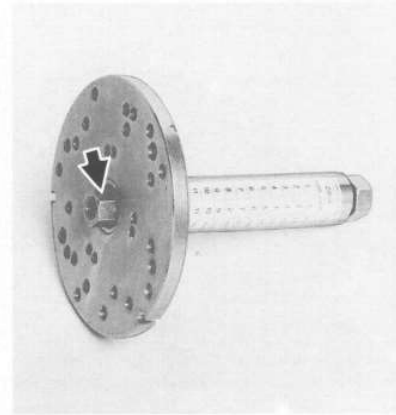

- Place the annular buffer in position, fit mounting screw and tighten down firmly.

- Extend the spindle of service tool ZS fully and then screw the threaded sleeve onto the spindle as far as it will go.

Top:  
Fitting crankshaft

Bottom:  
1 = Threaded sleeve 5910 893 2420  
2 = Screw thread on crankshaft stub

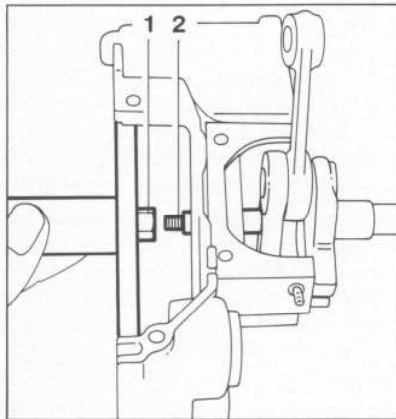
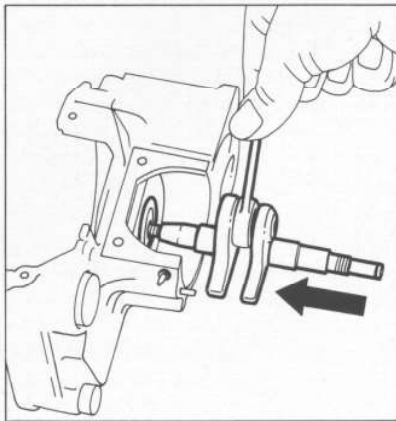

- Coat bearing seat of crankshaft stub at ignition end with oil and position it in the bearing from the inside of the crankcase.
- Screw the threaded sleeve onto the crankshaft stub.

Top:  
Screwing service tool into position

Bottom:  
Pulling crankshaft into ball bearing

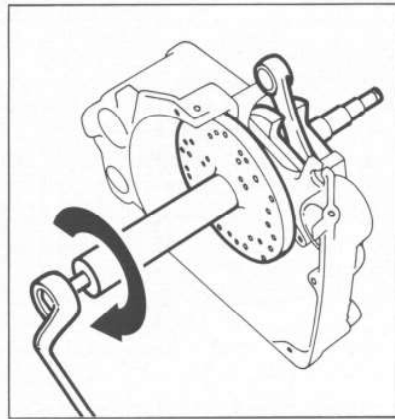
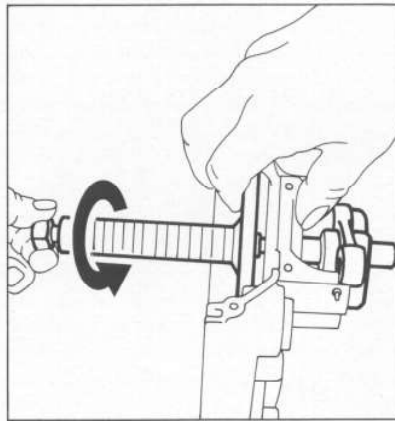

- Hold the service tool and crankshaft steady and rotate the spindle clockwise until the service tool butts against the crankcase.
- Pull the crankshaft into the bearing as far as it will go by turning the spindle clockwise.

**Important:** The connecting rod must point toward the cylinder flange while the crankshaft is being installed.

Top:  
Unscrewing service tool ZS

Bottom:  
Fitting crankcase gasket

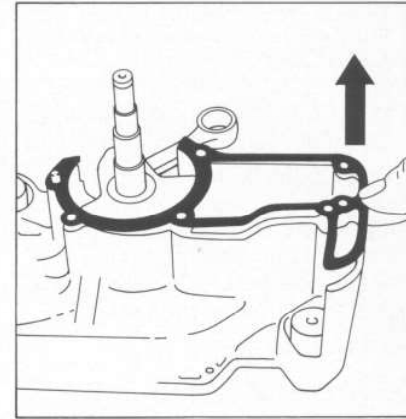
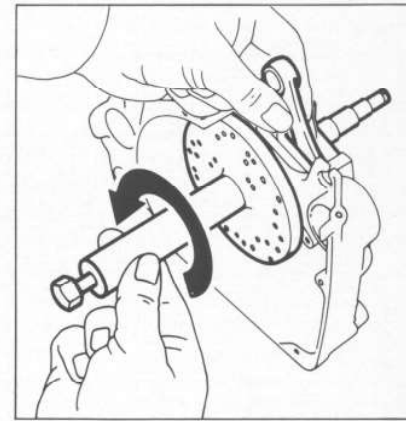

- Remove the service tool: Release the spindle by turning it counterclockwise and then unscrew the service tool counterclockwise.
- Fit a new gasket on the ignition side of the crankcase.

Top:  
Fitting crankcase

Bottom:  
Two screws fitted to prevent rotation

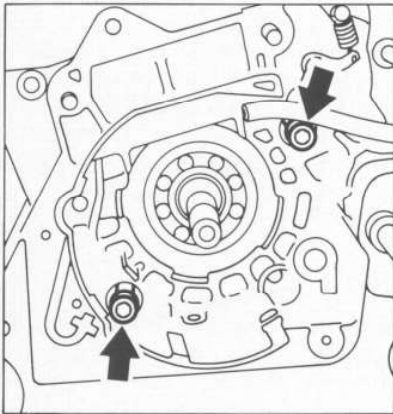

- Coat crankshaft stub at clutch end with oil and slide crankshaft into ball bearing as far as it will go.
- To prevent the crankcase and gasket twisting, fit M5x72 screws (from service tool ZS) in two crankcase holes.

Top:  
Threaded sleeve 5910 893 2409 fitted on spindle

Bottom:  
Mounting service tool AS

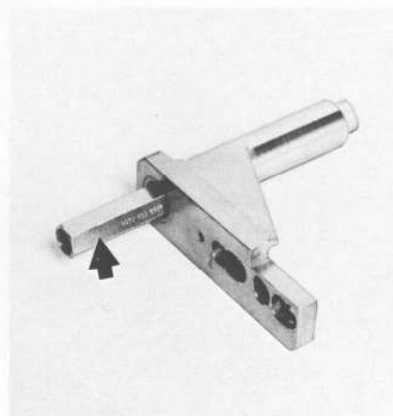

- Screw the spindle fully into service tool AS by turning it clockwise.
- Screw threaded sleeve onto the end of the spindle as far as it will go (left-hand thread).
- Slip the threaded sleeve over the crankshaft stub.

Pulling two halves of crankcase together

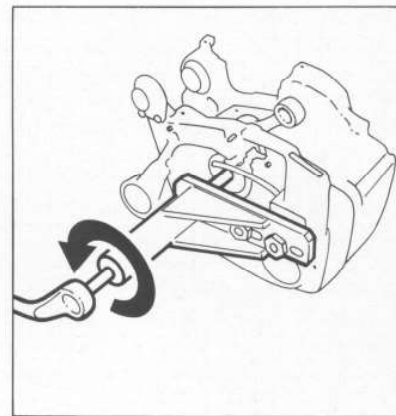

- Hold the crankshaft steady and screw the threaded sleeve onto the crankshaft stub by turning the spindle counterclockwise.
- Let go of the crankshaft. Hold the service tool steady and continue turning the spindle until the tool locates against the bar mounting face.
- Fit the two sprocket cover mounting nuts on the collar studs and tighten them down by hand.
- Rotate the spindle counterclockwise and thus pull the crankshaft into the bearing as far as stop.
- Remove the hexagon nuts, unscrew the spindle clockwise and lift away the service tool.
- Take out the two M5x72 screws.

Top:  
Fitting plug in crankcase

Bottom:  
Installation of oil seal at ignition side  
using installing tool 1128 890 3900  
a = 4.3 mm (11/64")

Assembly sleeve 1122 893 4600  
in position

Top:  
Pressing in oil seal at clutch side with  
press sleeve 1119 893 2401

Bottom:  
Heat shield foil on right-hand side wall

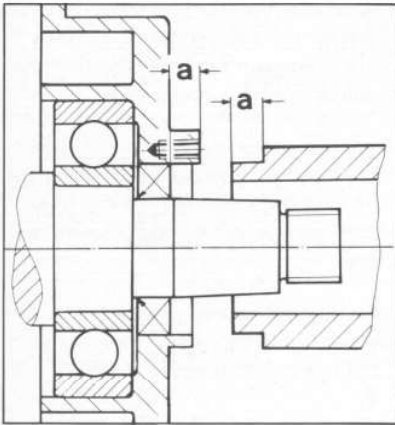
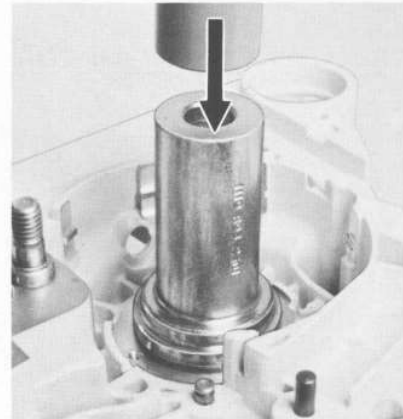
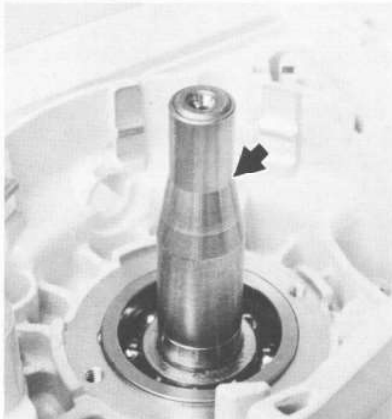
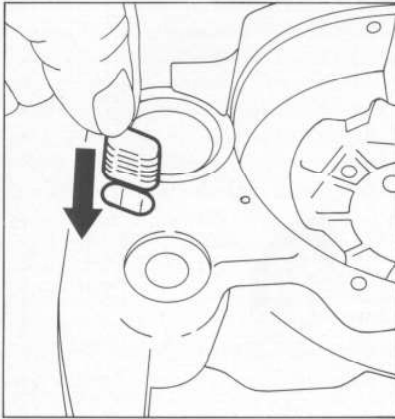

If the crankshaft does not turn freely, it is sufficient to tap the end of the stub with a plastic mallet to relieve axial stresses.

- Coat sealing lips of the oil seals with lubricating grease - see 12.2.
- Push the oil seal over the ignition end of the crankshaft (the open side of the seal must face the crankcase) and use the installing tool to press it home.

**Important:** The installed depth of the oil seal must be maintained in order to guarantee a good seal. Always use installing tool 1128 890 3900.

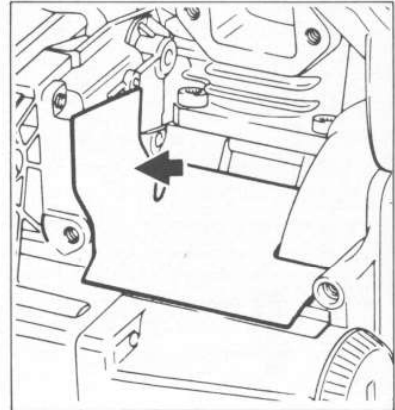

- Use a 5 mm (3/16") drift to drive the dowel pin into the two halves of the crankcase - from the chain tensioner side - and seal hole at other side with plug.
- Fit new mounting screws (property class 12.9) and tighten them down alternately in a diagonal pattern to 11 Nm (8.1 lbf.ft).

- Slip the assembly sleeve over the clutch end of the crankshaft.
- Push the oil seal over the assembly sleeve (the open side of the seal must face the crankcase) and use the installing tool to press it home.

Assembly of the remaining parts is a reversal of the disassembly sequence.

**Note:** Stick the new heat shield foil in position. To do this, first degrease the crankcase surface. When sticking in place, note that the heat shield must go up the right-hand side wall (see illustration).

**Note:** Trim away any excess gasket material in the area of the cylinder mounting face.

4.6 **Leakage Testing the Crankcase**

4.6.1 **Preparations**

Top:  
Carburetor and crankcase tester  
1106 850 2905

Bottom:  
Vacuum pump 0000 850 3500

Top:  
Muffler upper casing mounting screws

Bottom:  
Muffler lower casing mounting screws

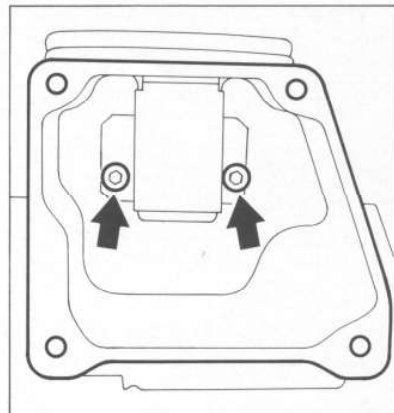
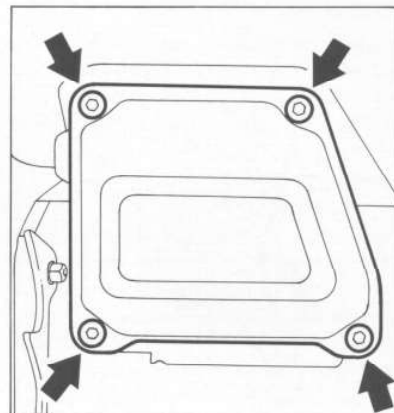
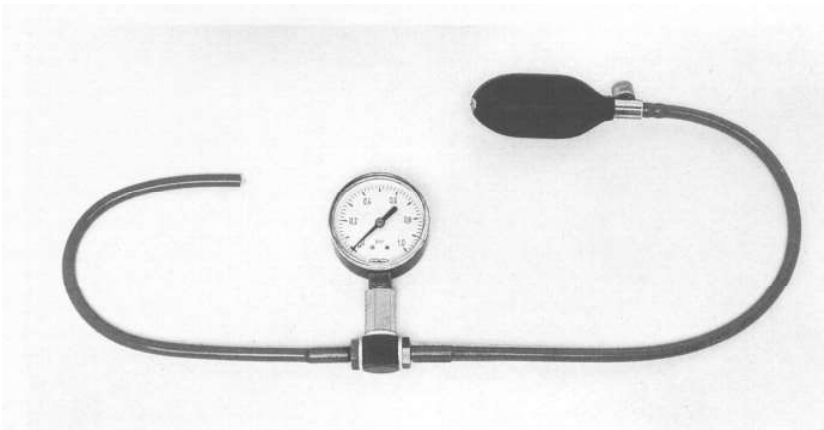

Defective oil seals and gaskets or cracks in castings are the usual causes of leaks. Such faults allow supplementary air to enter the engine and thus upset the fuel-air mixture.

This makes adjustment of the prescribed idle speed difficult, if not impossible.

Moreover, the transition from idle speed to part or full throttle is not smooth.

The crankcase can be checked accurately for leaks with the carburetor and crankcase tester and the vacuum pump.

- Take out the muffler upper casing mounting screws and remove the upper casing.
- Slacken off the muffler lower casing mounting screws about half way.

## 4.6.2 Pressure Test

Fitting sealing plate 0000 855 8105 between muffler lower casing and cylinder

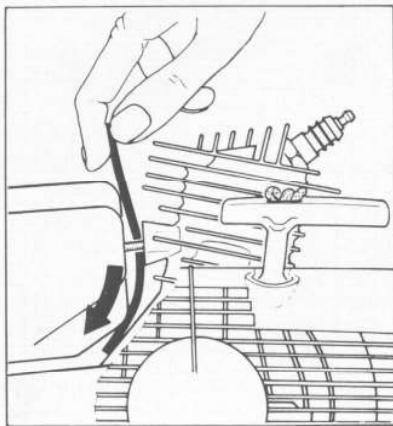

- Slide the sealing plate between the muffler lower casing and the cylinder exhaust port. Retighten the mounting screws moderately.

**Note:** The sealing plate must completely fill the space between the two mounting screws. Push the narrow end of the sealing plate home until it just locates under the lower casing.

- Retighten the two mounting screws moderately.
- Remove the carburetor - see 11.3.
- Set the piston to top dead center (T.D.C.). This can be checked through the inlet port.

Test flange 1113 850 4200 fitted on studs

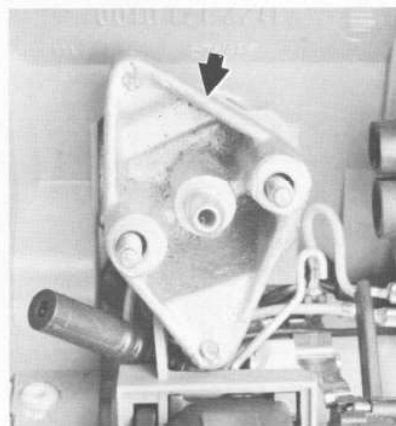

- Fit the test flange in place of the carburetor.
- Fit the two hexagon nuts and tighten them down moderately.

**Note:** The test flange locates against the manifold to produce an airtight seal. The lower pin in the test flange seals the impulse hose.

Top:  
Tester's pressure hose fitted on test flange nipple

Bottom:  
Closing the vent screw

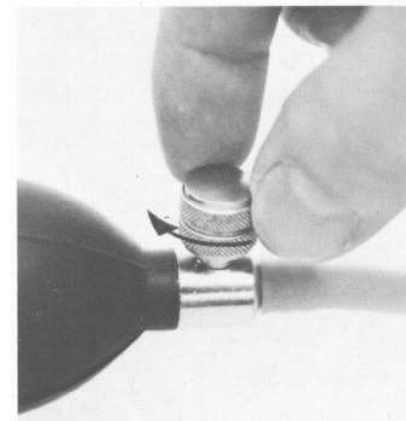
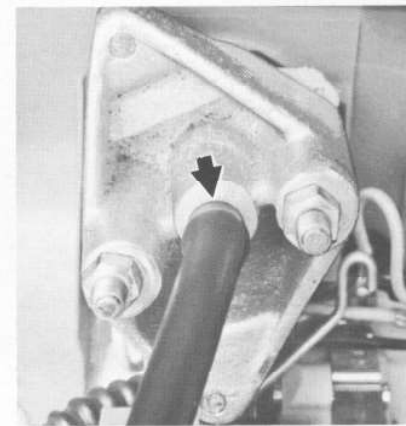

- Preparations - see 4.6.1.
- Connect tester's pressure hose to nipple on test flange.
- Make sure the spark plug is properly tightened down before starting the test.
- Close the vent screw on the rubber bulb.

## 4.6.3 Vacuum Test

Test setup with carburetor and crankcase tester 1106 850 2905

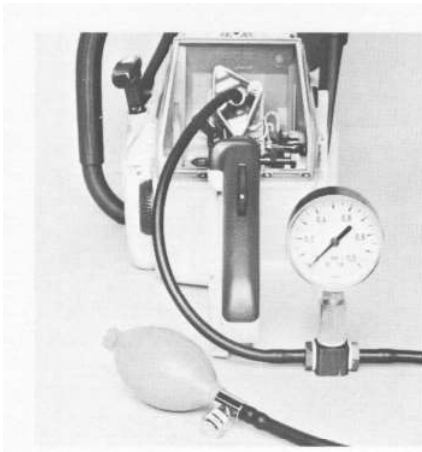

Test setup with vacuum pump 0000 850 3500

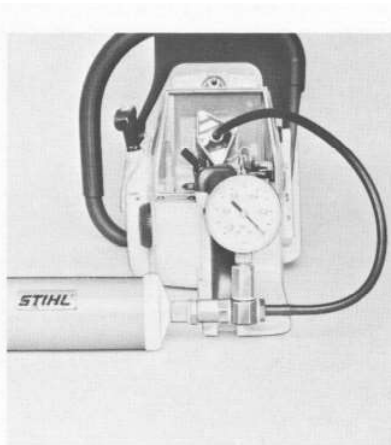

**Note:** When you release the pump piston, the non-return valve automatically seals the suction hose.

If the vacuum reading remains constant, or rises to no more than 0.3 bar (4.25 psi) within 20 seconds, it can be assumed that the oil seals are in good condition.

However, if the pressure continues to rise (reduced vacuum in crankcase), the oil seals must be replaced, even if no leaks were detected in the pressure test.

- Use rubber bulb to pump air into the crankcase.

The gauge must indicate a pressure of 0.5 bar (7.25 psi). If this pressure remains constant, the crankcase is airtight. However, if the indicated pressure drops, the leak must be located and the faulty part replaced. Coat the suspect area with oil and pressurize the crankcase again. If bubbles appear in the oiled area, replace the faulty part.

- After finishing the test, open the vent screw and disconnect the hose.

Reassemble the machine in the reverse sequence.

**Note:** Coat the mounting screws of both muffler casings with Loctite (see 12.2), refit them and tighten to the specified torque - see 4.1.

Oil seals tend to fail when subjected to a vacuum, i.e. the sealing lip lifts away from the crankshaft during the piston's induction stroke because there is no internal counterpressure.

An additional test can be carried out with the vacuum pump to detect this kind of fault. The preparations for this test are the same as for the pressure test - see 4.6.2.

- Connect the vacuum pump's suction hose to test flange nipple.
- Pull out the pump piston several times until the gauge indicates a vacuum of 0.5 bar (7.25 psi).

- After finishing the test, disconnect the hose.

Reassemble the machine in the reverse sequence.

**Note:** Coat the mounting screws of both muffler casings with Loctite (see 12.2), refit them and tighten to the specified torque - see 4.1.

4.7 Replacing the Oil Seals

Top:  
Woodruff key  
  
Bottom:  
Generator mounting screws

Top:  
Oil pump  
  
Bottom:  
Puller 0000 890 4400 with jaws  
0000 893 3711 (No. 6)

Top:  
Puller fitted at flywheel side  
  
Bottom:  
Puller fitted at ignition side

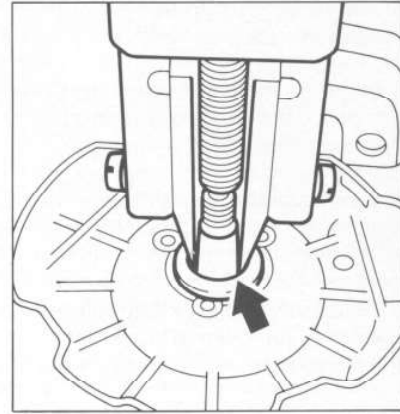
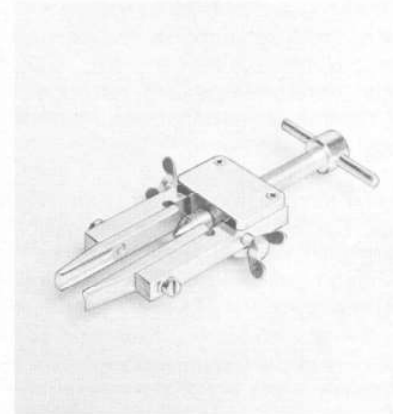
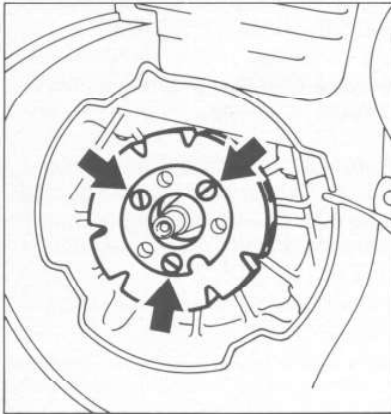
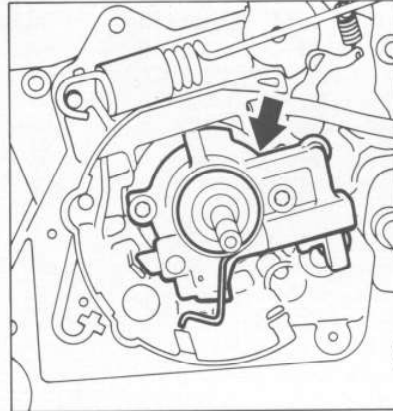
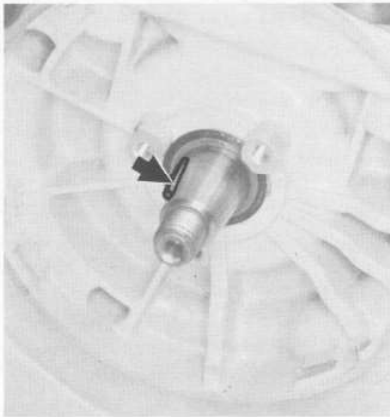

It is not necessary to disassemble the complete crankcase if only the oil seals have to be replaced.

- Remove the flywheel - see 5.1.5.
- Remove the Woodruff key from the crankshaft stub.

**Note:** On machines with heated handles, take out the generator mounting screws, remove the generator and put it to one side.

- Remove the clutch - see 3.2.
- Remove the brake band - see 3.3.1.
- Remove the oil pump - see 10.4.
- Fit No. 6 jaws in universal oil seal puller.

- Apply the puller and rotate the spindle clockwise to pull the oil seal out of the crankcase.

**Note:** When using the puller, make sure that it does not damage the crankshaft surface or the ball bearing cages.

Install the oil seals as described under 4.5.2.

- Refit the generator - see 9.5.

5. IGNITION SYSTEM

**Warning!** Exercise extreme caution when carrying out maintenance and repair work on the ignition system. The high voltages which occur can cause serious or even fatal accidents!

1 = Flywheel  
2 = Ignition module

1 = Flywheel  
2 = Wire for LED (066 only)  
3 = Ignition module (digital)

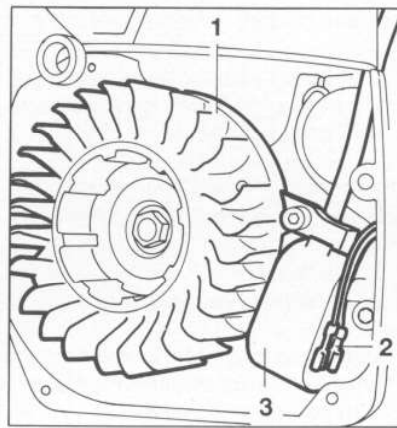
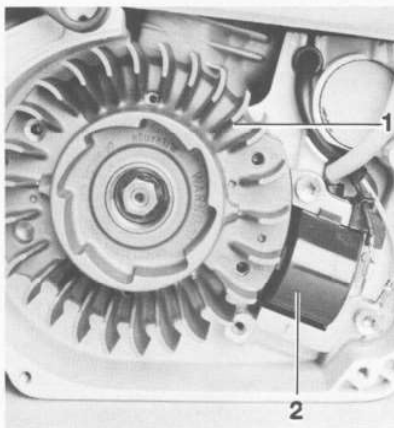

CDIC and CDIC A digital ignition modules feature an electronic cut-in threshold to prevent backfiring during engine starts. An ignition spark is generated only if the cranking speed of the crankshaft is high enough for its mass moment of inertia to overcome combustion pressure.

Cut-in threshold:  
CDIC ignition module (064) = 1,200 rpm  
CDIC A ignition module (066) = 500 rpm

Older STIHL 064 saws are equipped with a transistor-controlled electronic (breakerless) magneto ignition system which requires no outside power source (battery or dynamo).

The system consists basically of an ignition module and flywheel and is easily accessible.

**Note:** A special flywheel is installed in models with heated handles (with ring magnet for the generator).

Analog ignition systems can be converted to a digital system. This necessitates changing the flywheel and carburetor.

Model 064 saws from machine number X 18 761 250 are equipped with an electronic digital ignition which features a maximum speed governor and requires no outside power source.

The STIHL 066 is also equipped with an electronic digital ignition with a maximum speed governor.

The ignition module installed in the 066 has a second connection for a light emitting diode (LED) which aids carburetor adjustment.

In the digital ignition system the zero values of the magnetic flux in the magnetic field between the flywheel and ignition module yoke are evaluated to determine ignition timing. This means that ignition timing is tied to fixed physical values and can be varied only by the electronically stored advance curve as a function of engine speed.

When using the spark test to check installed digital ignition modules with the spark plug unscrewed, make sure that the starter rope is pulled at a sufficiently high speed. If there is no spark at the plug when the starter is pulled, repeat the test at a higher cranking speed.

## 5.1 Repairing Component Parts

### 5.1.1 Spark Plug

#### Troubleshooting on the ignition system should always begin at the spark plug.

In the event of starting difficulties, low engine power, misfiring, etc., unscrew the spark plug and check that it is the approved type. Only the spark plugs listed in the specifications may be used. Other makes of spark plug are unsuitable because they have long-reach electrodes.

Unlike analog ignition systems, the spark plug is a functional component of ignition timing in machines with digital ignition. The internal circuitry is designed for suppressed spark plugs. For this reason only install one of the spark plugs listed in the specifications. The following faults may occur if other spark plugs are used:

- Misfiring at idle speed
- Misfiring when warm machine is running at cutting speed
- Misfiring during acceleration
- Detonations in the crankcase at idle speed and full load.

Sooted or carbonized spark plug:

- Use brass wire brush to clean the spark plug and then blow it clear with compressed air.

**Note:** Never use a steel wire brush for this job.

Spark plug smeared with oil:

- Wash the insulator nose with a grease solvent and blow it clear with compressed air.

Electrode gap:

Electrode gap becomes wider as a result of normal erosion.

Top:  
Checking electrode gap with feeler gauge

Bottom:  
Resetting electrode gap with Bosch spark plug gauge

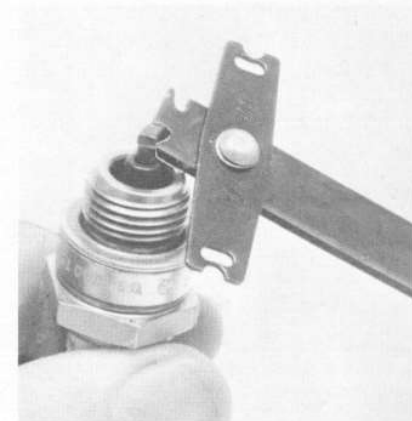
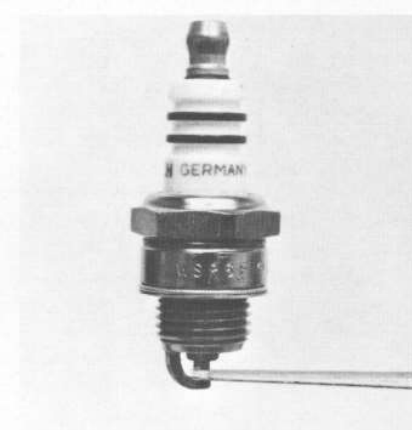

- Check the gap at regular intervals with a feeler gauge. It should be 0.5 mm (0.02").
- Bend the ground electrode as necessary.

**Important:** Always fit a new spark plug if the electrodes are badly pitted.

Checking the spark plug:

Accurate checking of the spark plug is only possible with a special spark plug tester.

A provisional check can be carried out by fitting a clean spark plug in the spark plug terminal and holding it against ground. There should be a powerful sparkover at the electrodes when the engine is cranked by pulling the starter rope.

**Warning:** Do not touch any live parts - contact with high voltage can cause serious or fatal accidents!

**Note:** It is recommended that a new spark plug be fitted in all cases of doubt.

If there is no sparkover even though the spark plug is in good condition, first check the lead connections.

**Note:** Chafed insulation on the ignition lead or short circuit wire will cause a short-circuit to ground. In this case the engine will either not start or only run erratically.

To install the spark plug:

- Clean the spark plug seat and inspect the sealing ring to make sure it is in good condition.
- Fit the spark plug and tighten it down to a torque of 25 Nm (18.5 lbf.ft).

The appearance of the spark plug's insulator nose gives valuable information with regard to the effects of various operating conditions:

Condition of Insulator Nose	Appearance	Meaning
<b>Normal:</b>	Grayish yellow-to-brown, dry as specified	Engine in order, correct spark plug (heat range)
<b>Sooted:</b>	Velvet-like, dull black coating of soot	Mixture too rich, lack of air (dirty air filter, choke shutter partly closed), electrode gap too wide, wrong spark plug (heat range too high)
<b>Smearred with oil:</b>	Coating of damp oil carbon and soot	Too much oil in fuel mix
<b>Overheated:</b>	Welding beads on insulator nose, pitted electrodes (heat range too low)	Mixture too lean, spark plug loose, wrong spark plug (heat range too low)

5.1.2 Ignition Lead/Spark Plug Terminal

Top:  
Ignition lead in crankcase retainer

Bottom:  
Removing dust seal

Top:  
Pulling leg spring out of spark plug terminal

Bottom:  
Attaching leg spring

Correct position of leg spring in spark plug terminal

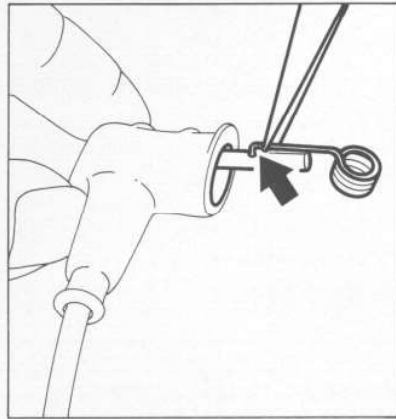
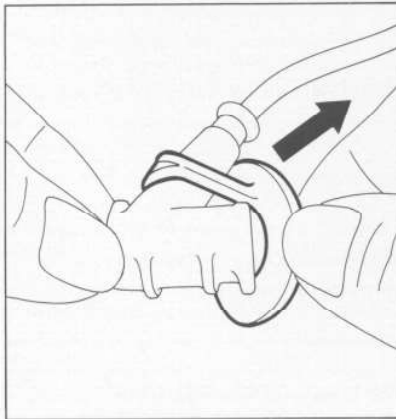
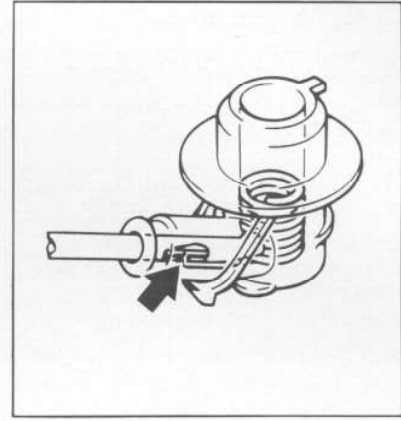
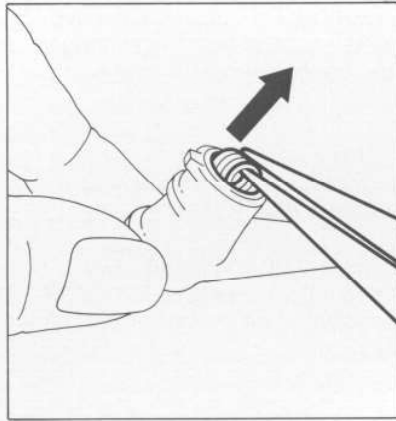
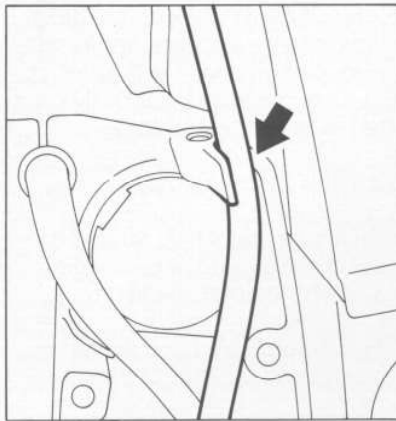

- Use a suitable pair of pliers to grip the end of the ignition lead inside the spark plug terminal and pull it out.
- Pinch the hook of the leg spring into the center of the lead, about 15 mm (5/8") from the end of the lead.
- Pull the lead back into the terminal so that the leg spring locates properly inside it (see illustration).
- Slip the dust seal over the spark plug terminal.

- Remove the air filter - see 11.1.
- Remove the shroud - see 3.2.
- Remove the ignition module - see 5.1.6.2.
- Pull the ignition lead out of its retainer on the crankcase.
- Remove the insulating tube from the ignition lead.
- Pull the dust seal off the terminal and push it down the ignition lead.

- Use a suitable pair of pliers to grip the leg spring and pull it out of the spark plug terminal.
- Disconnect leg spring from the ignition lead and slip the spark plug terminal off the lead.
- Coat the end of the ignition lead and insulating tube with oil (about 20 mm / 3/4" long).
- Fit spark plug terminal over the ignition lead.

- Use a pointed tool to pierce the center of the other end of the ignition lead.
- Slip the insulating tube over the ignition lead.
- Screw the ignition lead into the ignition module. Refit the ignition module - see 5.1.6.2.
- Refit the shroud - see 3.2.
- Refit the air filter - see 11.1.

5.1.3 Short Circuit Wire/  
Ground Wire

Removing contact sleeve



Top:  
Using hook 5910 890 2800 to pull short circuit wire through the carburetor box

Bottom:  
Insulating tube in both retainers on crankcase  
1 = Lateral grommet



Short circuit wire on ignition module's connector tag

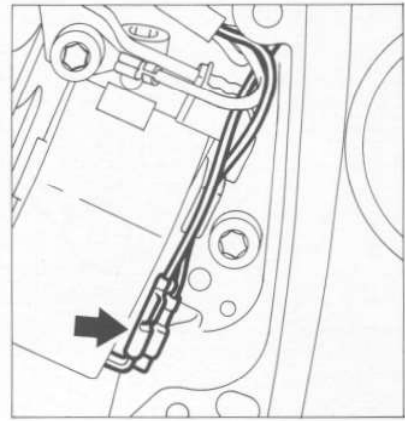

If the insulation of the short circuit wire is damaged it can cause a short circuit to ground and upset or completely interrupt ignition.

To following parts must be removed to replace the short circuit and ground wires:

- Fan housing
- Carburetor box cover
- Air filter with filter base
- Spark plug terminal
- Shroud - Carburetor.

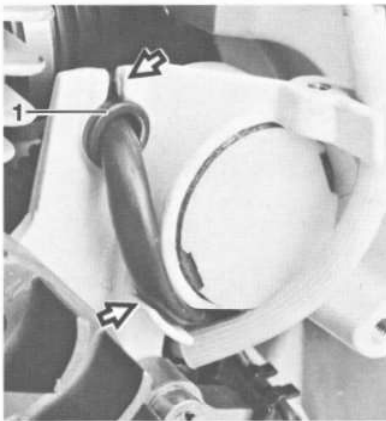

- Pull the short circuit wire off the connector tag on the ignition module and pull it through the grommet and insulating tube.

- To install new short circuit wire:

- Thread the short circuit wire through the insulating tube and grommet.

- Press the grommet into the tank housing.

- Connect short circuit wire to the tag on the ignition module.

To replace the short circuit wire:

- Move Master Control to "Choke".
- Use a small screwdriver to ease the contact sleeve of the short circuit wire out of its seat in the switch shaft.
- Cut off the contact sleeve.

- Use assembly hook to pull the short circuit wire through the carburetor box in the direction of the grommet.

- Use a blunt tool to push the grommet out of the carburetor box in the direction of the cylinder.

- Use a screwdriver to push the grommet in the crankcase wall inwards and take it away.

- Remove insulating tube with wires from the two retainers on the crankcase.

- Use the assembly hook to pull the short circuit wire through the carburetor box.

1 = Impulse hose  
2 = Short circuit wire

Top:  
Ground wire on contact spring's tag

Bottom:  
Ground wires on switch's twin  
connector tag

Ground wire fastening screw on  
ignition module

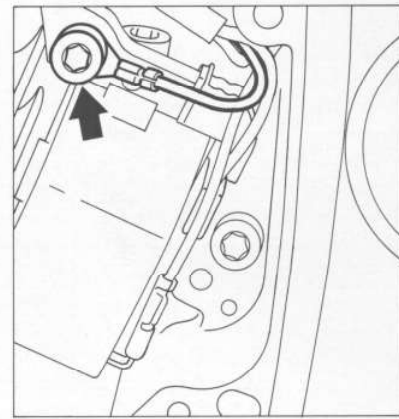
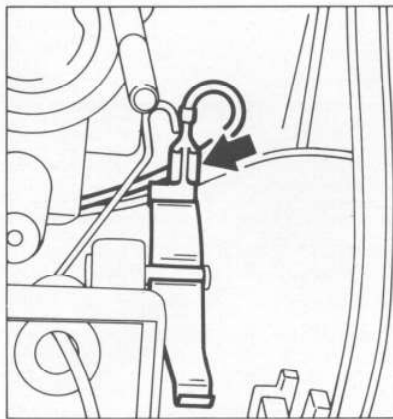
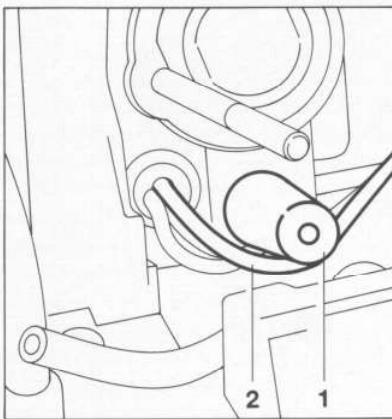

**Note:** The short circuit wire must be underneath the impulse hose.

Assembly is now a reversal of the disassembly sequence.

To replace the ground wire:

A ground wire is installed because the contact spring in the polymer tank housing is not connected to ground on the ignition module.

Use a suitable screwdriver to ease the ground wire terminal off the tag on the contact spring.

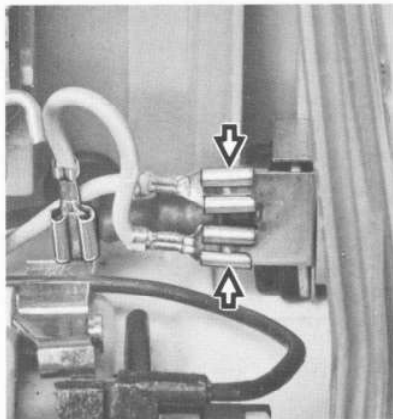

- Cut the terminal socket off the ground wire.
- Use a screwdriver to push the grommet in the crankcase wall inwards and take it away.
- Use a blunt tool to push the grommet out of the carburetor box in the direction of the cylinder.
- Remove the ground wire fastening screw from the ignition module.
- Withdraw the ground wire from the grommet and insulating tube.

Installation of the new ground wire is a reversal of the removal sequence.

**Note:** On "W" versions the ground wire is connected to the twin connector tag on the switch (upper tag). An additional ground wire connects the contact spring to the twin connector tag (lower tag).

- Use the assembly hook to pull the ground wire through the carburetor box in the direction of the grommet.

5.1.4 Stop Contact

Top:  
Contact sleeve locates against  
contact spring

Bottom:  
1 = Ground wire from LED  
2 = Ground wire from ignition module

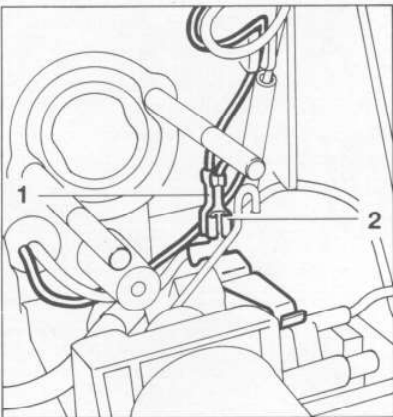
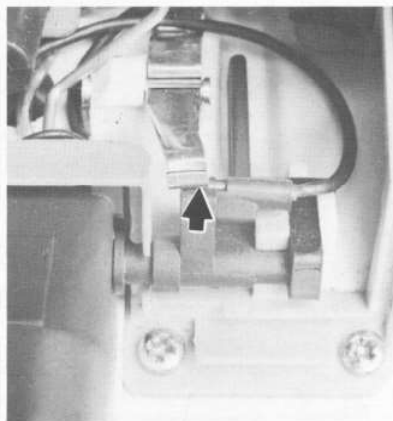

The short circuit system is in order if the short circuit wire's contact sleeve locates against the contact spring when the Master Control lever is in the "STOP" position. A continuity test with an ohmmeter must show  $\Omega$  S2.

- Remove the switch shaft - see 8.3.

Top:  
Ground wire from ignition module

Bottom:  
Removing contact spring from shaft

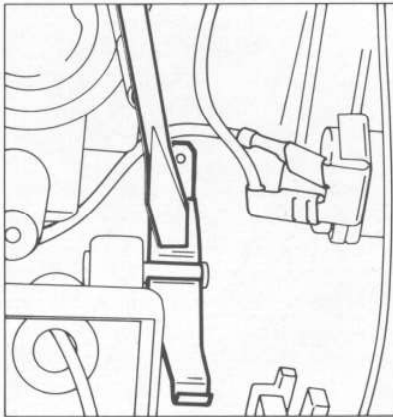
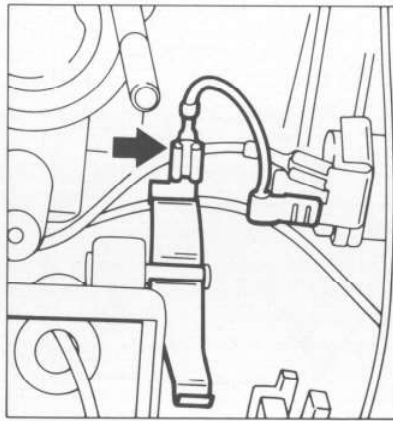

**Note:** Only one ground wire is attached to the contact spring of machines without LED.

- Use a screwdriver to press the contact spring down and off the shaft.

Top:  
Pushing shaft sideways through  
bearing bore

Bottom:  
Pushing shaft back into bearing bore

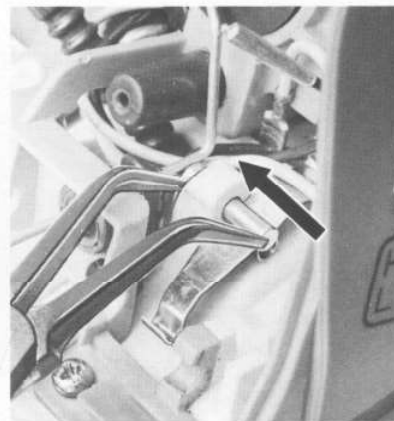

- Use bent nose pliers to push the shaft to the left through the bearing bore in the housing web.

- Take the contact spring out of the tank housing and fit a new one in its place.

- Use a screwdriver to push the shaft to the right and fully into the bore in the housing web.

5.1.5 Flywheel

Engaging contact spring

Top:  
Fan housing mounting screws

Bottom:  
Releasing flywheel mounting nut

Top:  
Puller 1110 890 4500

Bottom:  
Removing the flywheel

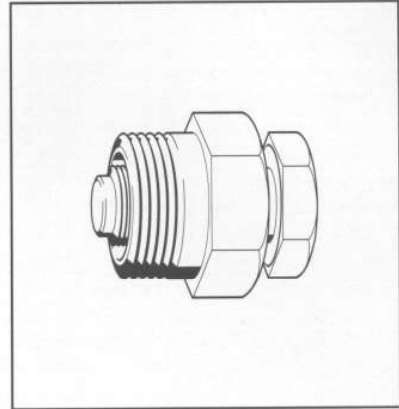
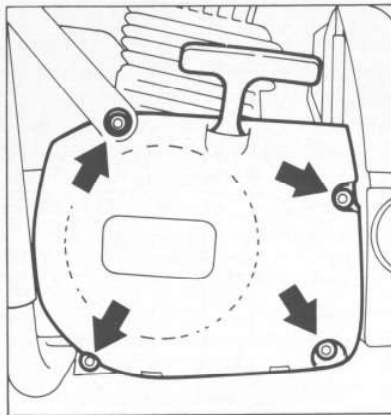
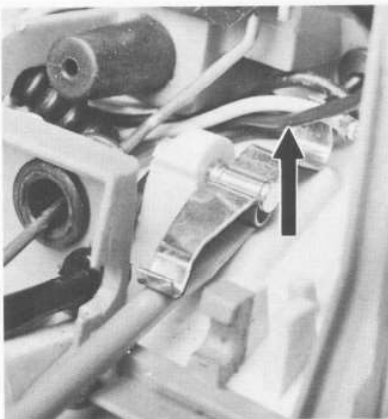

- Position a screwdriver under the contact spring and lever it upwards until it snaps into place.
- Connect ground wire terminal socket to tag on contact spring.

**Note:** On "W" versions the ground wire does not go directly from the contact spring's tag to the ignition module. A short "W" ground wire is connected to the twin connector tag on the switch. A second ground wire goes from there to the ignition module.

Installation is now a reversal of the removal sequence.

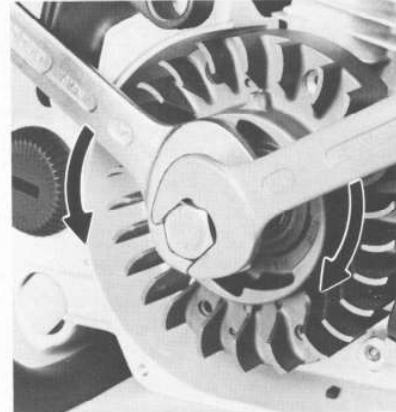

**To remove the flywheel:**

- Use the locking strip to block the piston - see 3.2.
- Take out the fan housing mounting screws and remove the fan housing.
- Rotate the flywheel so that the magnet poles are opposite the ignition module.
- Unscrew the flywheel mounting nut from the crankshaft.

- Screw the puller into the flywheel as far as stop.
- Hold the puller steady with a 24 mm open-end wrench and tighten down the thrust bolt until the flywheel comes away from its seat on the crankshaft.
- Take off the flywheel.

5.1.6 Ignition Module

- 1 = Flywheel (064)
- 2 = Flywheel (066)
- 3 = Magnet poles
- 4 = Magnet poles

Markings on flywheel  
 B = Analog ignition  
 P = Digital ignition

- 1 = Connector tag for short circuit wire
- 2 = High voltage output
- 3 = Connector tag for LED wire (066 only)

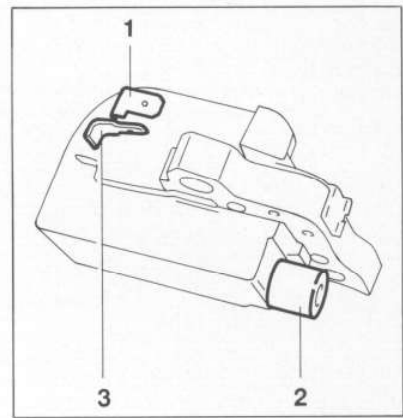
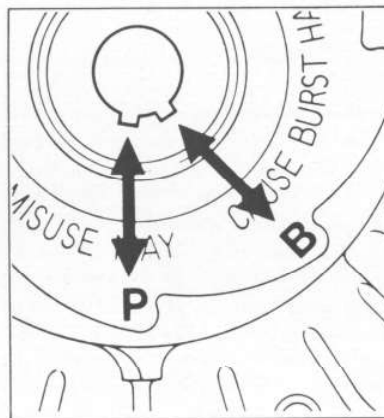
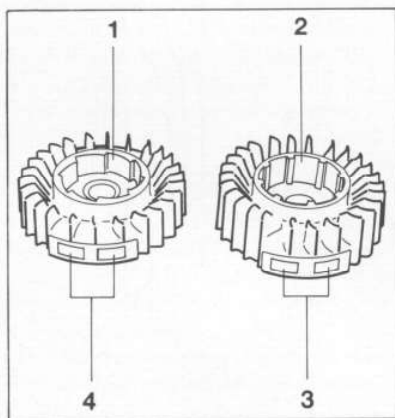

- Inspect the flywheel and magnet poles for any signs of cracks or other damage. Fit a new flywheel if you find any damage.

To install the flywheel:

- Check that Woodruff key is correctly positioned.

**Important:** Clean the stub of the crankshaft and the flywheel hub bore with a suitable standard commercial, solvent-based degreasant. Fit the flywheel in place. On model 064 the position of the Woodruff key differs by 40° for analog and digital ignitions. Replacement flywheels have two slots to take this into account. If an analog ignition module is fitted (Bosch), install the flywheel in position "B". Use position "P" for digital ignition modules (Prüfref).

The flywheel of 064 saws from machine number X 22 179 109 has only one key slot. This flywheel may only be installed in machines with digital ignition systems. Model 066 saws have been equipped with digital ignition modules since start of production and their flywheels have only one key slot.

- Fit mounting nut and tighten it down to a torque of 33 Nm (24.3 lbf.ft).

Assembly of the remaining parts is now a reversal of the disassembly sequence.

The ignition module accommodates all the components required to control ignition timing. There are either two or three electrical connections on the coil body, i.e.:

1. Connector tag for short circuit wire
2. High voltage output
3. Connector tag for LED wire

In the event of a fault in one of the integrated elements, the ignition module will malfunction and must be replaced as a complete unit.

When using the spark test to check installed digital ignition modules with the spark plug unscrewed, make sure that the starter rope is pulled at a sufficiently high speed. If there is no spark at the plug when the starter is pulled, repeat the test at a higher cranking speed. If there is still no spark, replace the digital ignition module.

5.1.6.1 Ignition Timing

5.1.6.2 Removing and Installing

Ignition timing on the transistor - controlled magneto ignition systems is fixed at 2.6 - 3.4 mm (0.10" - 0.13") B.T.D.C. at 8,000 rpm on the 064 and 2.9 - 3.9 mm (0.11" - 0.15") B.T.D.C. at 8,000 rpm on the 066. It is not adjustable. However, in view of the permissible tolerances in the electronic circuit, it may vary between 2.5 - 3.5 mm (0.09" - 0.14") B.T.D.C. at 8,000 rpm.

Since there is no mechanical wear in these systems, ignition timing cannot get out of adjustment. However, an internal fault in the circuit can alter the switching point in such a way that a spark test will still show the system to be in order although timing is outside the permissible tolerance. This will impair engine starting and running behavior.

Top:  
 1 = Wire retainer  
 2 = Wire to LED (066 only)  
 3 = Short circuit wire  
 Bottom:  
 Digital ignition module mounting screws

Top:  
 Pulling unscrewed ignition lead out of ignition module  
 Bottom:  
 Removing wire retainer from ignition module

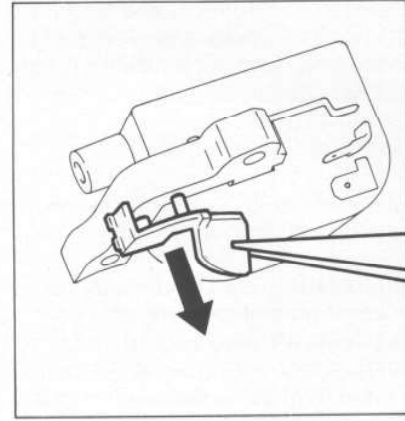
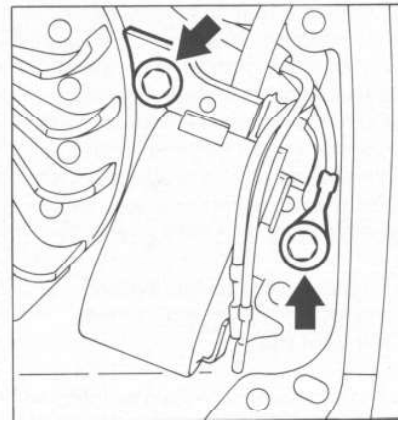
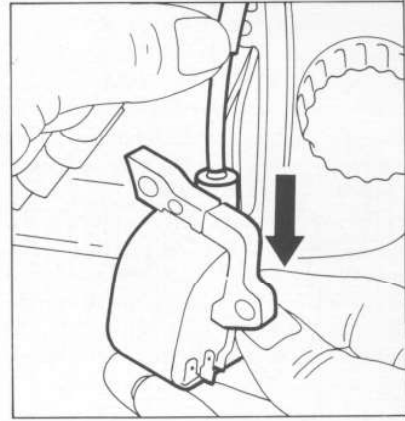
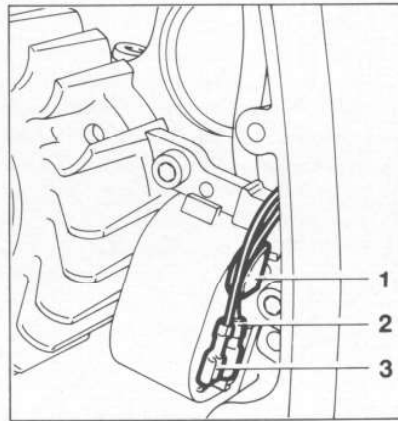

- Remove fan housing - see 5.1.5.
- Disconnect short circuit wire and wire to LED (on 066) from tags on ignition module and take them out of the retainer.
- Remove the ignition module mounting screws.

- Unscrew the ignition lead from the contact pin. To do this, rotate the ignition module and pull the lead out of the high voltage output.
- If necessary, remove the wire retainer from the module.

**Note:** The digital ignition module can be installed in saws from machine number X 18 761 250, or saws with a new crankcase, which have a third mounting boss for the yoke of the digital ignition module.

5.1.7 LED (066 only)

Setting gauge 1111 890 6400 inserted between flywheel and ignition module

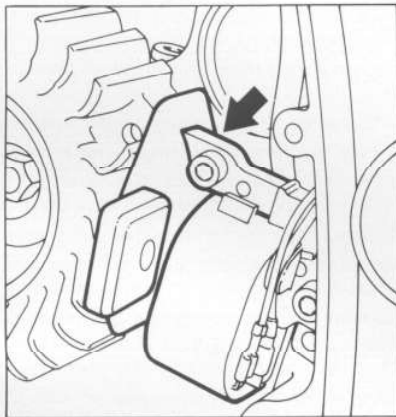

Top:  
Terminal socket on contact spring  
Bottom:  
Separating plug-in connection  
1 = Insulating tube

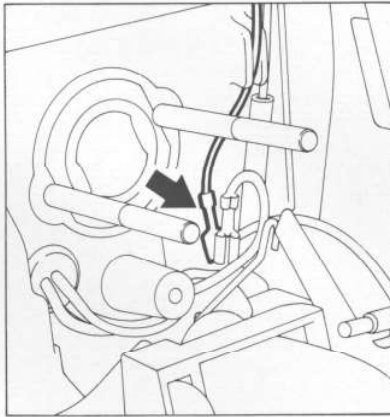

Top:  
Withdrawing LED

Bottom:  
Correct position of wires in carburetor box

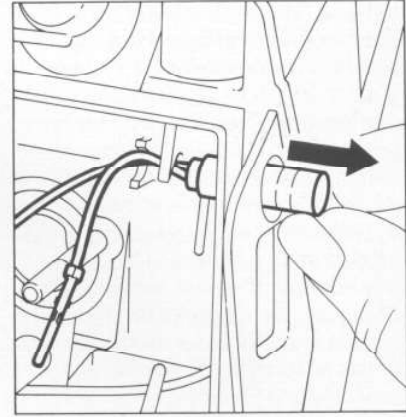

It is also necessary to change the flywheel and fit the new WJ 10 A carburetor (because of maximum speed governor). Adjust and finetune the carburetor after installation - see 11.7.

- Refit the ignition lead by screwing it into the high voltage output.
- Coat the threads of the module mounting screws with Loctite (see 12.2). Place the ignition module in position, insert the screws with washers (fit ground wire under lower screw) but do not tighten down yet.
- Slide the setting gauge between the arms of the ignition module and the flywheel magnets.
- Press the ignition module against the flywheel. Tighten down the mounting screws to a torque of 9 Nm (6.6 lbf.ft) and withdraw the setting gauge.
- Fit the fan housing.

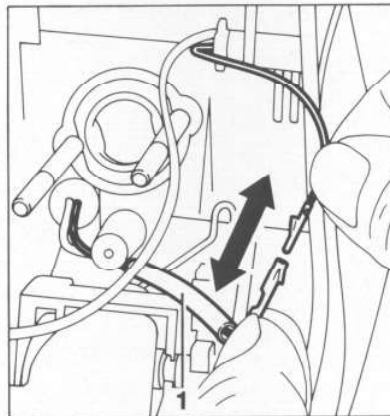

The LED aids correct adjustment of the carburetor (without a tachometer) on machines with a digital ignition.

- Remove the carburetor - see 11.4.
- Ease the terminal socket off the contact spring.
- Pull the insulating tube off the plug-in connection and separate the two wires.

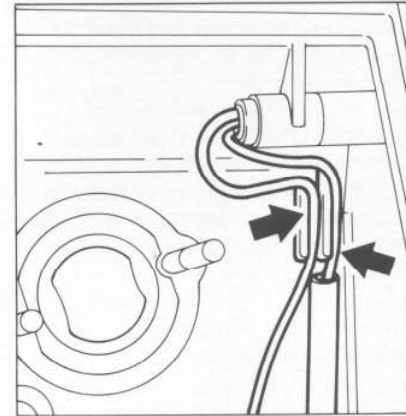

- Push the LED out of its seat and remove it from the carburetor box.

Installation is a reversal of the removal sequence.

**Note:** After installation, press the wires into the retainers in the carburetor box (see illustration).

6. REWIND STARTER

6.2 Rope Rotor/Pawls

6.1 Routine Maintenance

If the action of the starter rope becomes very stiff and the rope rewinds very slowly or not completely, it can be assumed that the starter mechanism is in order but plugged with dirt. At very low outside temperatures the lubricating oil on the rewind spring may thicken and cause the spring windings to stick together. This has a detrimental effect on the function of the starter mechanism. In such a case it is sufficient to apply a few drops of paraffin (kerosine) to the rewind spring.

Then carefully pull out the starter rope several times and allow it to rewind until its normal smooth rewind until its normal smooth action is restored.

If clogged with dirt or pitch, the entire starter mechanism, including the rewind spring, must be removed and disassembled. Take special care when removing the spring.

Wash all parts in paraffin or white spirit.

Lubricate the rewind spring and starter post with STIHL special lubricant, see 12.2, before installing.

Removing spring clip

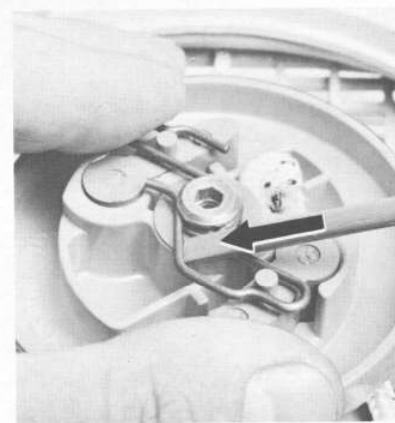

Removing rope rotor

Troubleshooting chart - see 2.4.

The fan housing has to be removed for access to the starter mechanism - see 5.1.5.

Relieve tension of rewind spring:

- Pull out the starter rope to a length of approx. 30 cm (1 ft) and hold the rope rotor steady.
- Catch the starter rope between the rope guide bush and the rope rotor and pull it out.
- While still holding the rope rotor steady, take three full turns off the rope rotor.
- Pull out the rope with the starter grip and then let go off the rope rotor.

**Note:** The rope rotor will spin back and thus relieve the tension on the rewind spring. The rewind spring will not be under tension if the starter rope is broken.

- Use a screwdriver or suitable pair of pliers to carefully remove the spring clip from the starter post.
- Take the washer and rope rotor with pawls off the starter post.
- Remove the pawls and check to see if they are in good condition, replace if necessary.
- Replace the broken or worn starter rope - see 6.3.

Installing the rope rotor

- Coat the bore in the rope rotor with STIHL special lubricant (see 12.2). Fit the rotor on the starter post so that the inner spring loop slides into the lug on the rotor.

**Note:** Check that the spring loop has engaged by turning the rope rotor slightly and letting it go - it must spin back.

- Coat the pegs of the pawls with graphite grease, see 12.2, and fit the pawls.
- Fit the washer and install the spring clip in the starter post groove.

**Note:** Make sure the spring clip engages on the pawl guide pegs and points them in the clockwise direction.

- The spring clip must be treated very carefully. If it is bent during disassembly or assembly, the rewind starter might malfunction.
- Tension the rewind spring - see 6.5.

### 6.3 Replacing the Starter Rope

Top:  
Pushing starter rope through from rear side of rope rotor

Bottom:  
Starter rope secured in rope rotor with knot

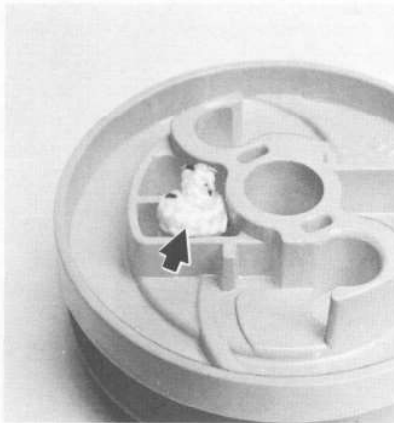
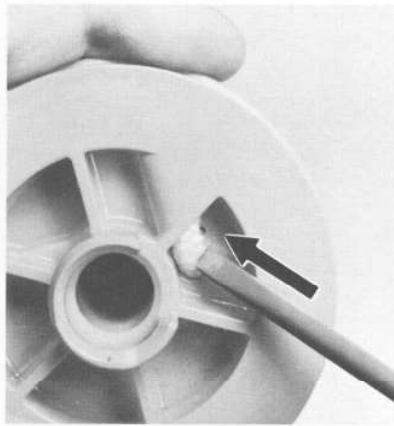

Top:  
1 = Special knots  
2 = Rope guide bush

Bottom:  
Special knots used

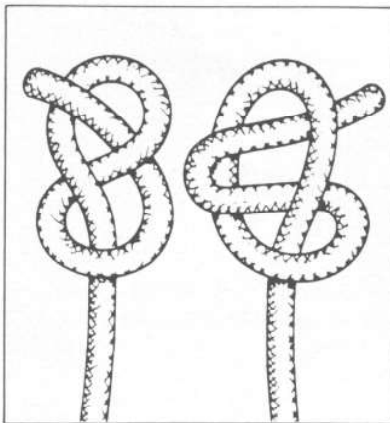
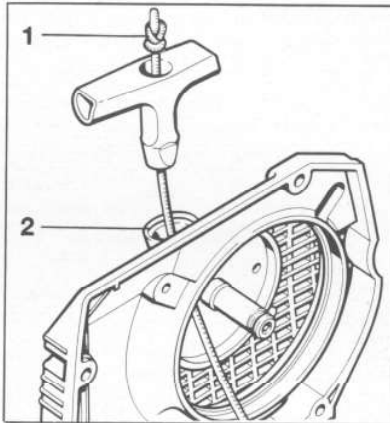

- Remove the rope rotor - see 6.2.
- Remove the remaining rope from the rope rotor. Thread one end of a new 4.5 mm (3/16") dia. and 1000 mm (39 7/16") long rope through the side of the rope rotor and then, from the underside, into the inner hole and pull it up to the top side. Secure the rope with a simple overhand knot.
- Pull the rope back so that the knot locates in the recess in the rope rotor.

- Thread the other end of the rope through the guide bush from inside the fan housing and through the starter grip. Secure with one of the special knots shown.
- Install the rope rotor - see 6.2.

### 6.4 Replacing the Rewind Spring

Top:  
Prying spring loop off the lug

Bottom:  
1 = Annular groove in fan housing  
2 = Pads on spring housing

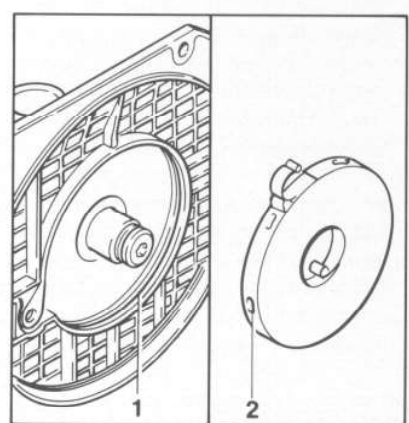
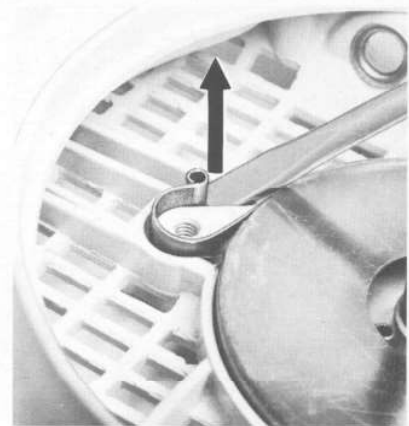

- Remove the rope rotor, see 6.2, and pry out the spring housing. Use pliers to remove the bits of the broken spring from the fan housing.

**Note:** New rewind spring housings have six raised pads on their circumference and there is an annular groove in the spring seat of new fan housings (see illustration). This prevents axial movement of the spring. Rewind springs with pads can also be installed in fan housings which have no annular groove.

### 6.5 Tensioning the Rewind Spring

Pressing home rewind spring with press disk 5910 893 5100

Top:  
Position of outer spring loop  
a = 25 mm (1")

Bottom:  
Fitting rewind spring with aid of wooden assembly block 1108 893 4800

Top:  
Winding starter rope onto rotor

Bottom:  
Making a loop in the rope

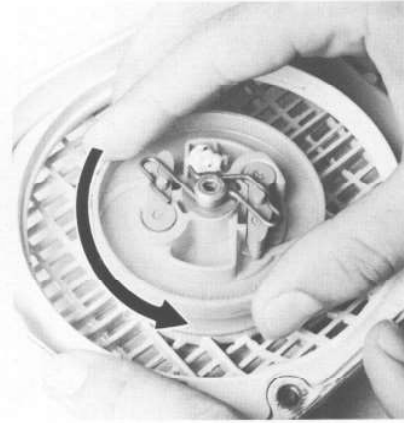
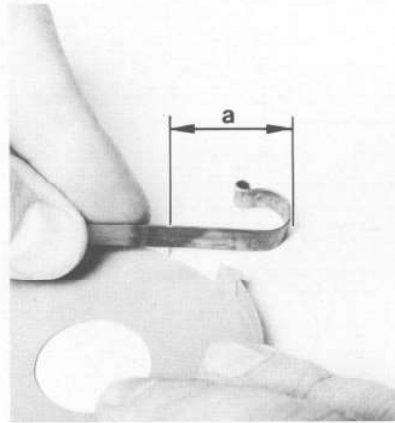
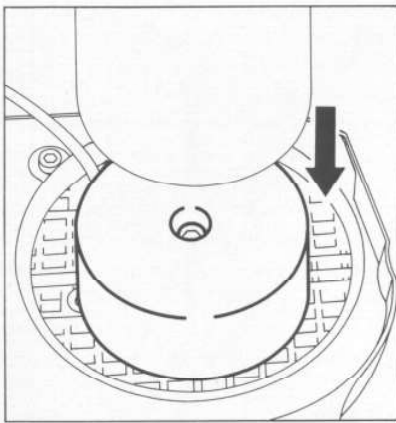

- The replacement spring is supplied with spring housing ready for installation. It should be lubricated with a few drops of STIHL special lubricant (see 12.2) before installation.
- Position the replacement spring with spring housing (bottom plate must face up) in the fan housing. Make sure the outer spring loop engages the recess in the fan housing.

**Important:** The pads on the spring housing mean that a certain resistance has to be overcome when installing the spring. Apply pressure evenly over the whole surface of the spring housing to prevent it being twisted.

**Important:** If the rewind spring pops out and uncoils during installation, it must be refitted in the spring housing as follows:

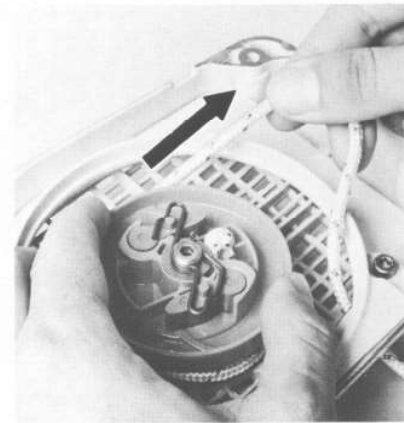
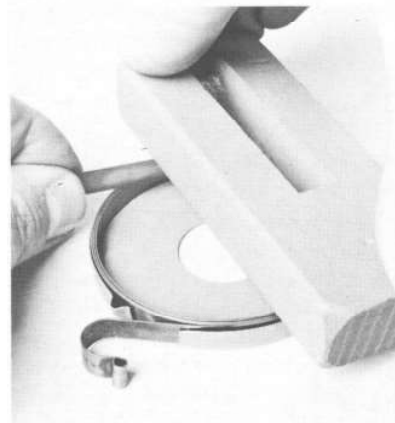

- Position the outer spring loop about 25 mm (1") from the edge of the spring housing.
- Refit the rewind spring in the spring housing in the counterclockwise direction, starting from the outside and working inwards.

**Note:** The wooden assembly block can be placed over the spring housing to simplify refitting.

- Install the rope rotor - see 6.2.

- Pull the starter rope out to full length. Rotate the rope rotor counterclockwise to wind on the rope until the starter grip is about 20 cm (8") from the fan housing.
- Grip the rope between the rope rotor and fan housing, pull it out and make a loop.

### 6.6 Replacing Starter Rope Guide Bush

Rotating rope rotor clockwise (tensioning rewind spring)

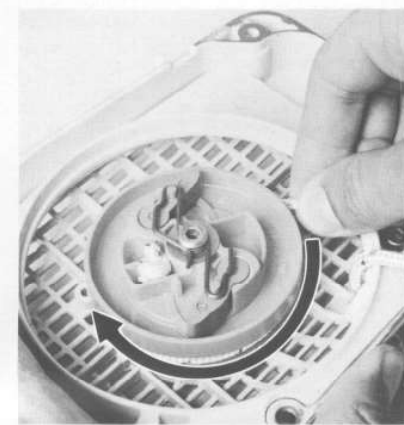

Prying out worn starter rope guide bush

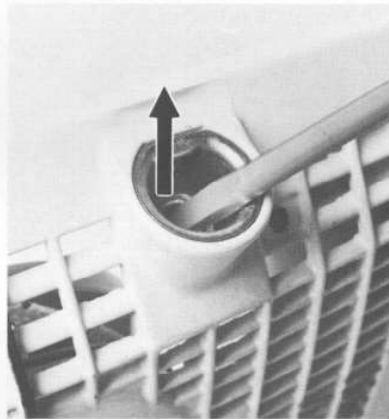

Top:  
Fitting new rope bush with installing tool 0000 890 2201 (schematic)  
1 = Screw spindle  
2 = Fan housing  
3 = Rope guide bush  
4 = Thrust sleeve  
5 = Hexagon nut

Bottom:  
Flaring the new rope bush

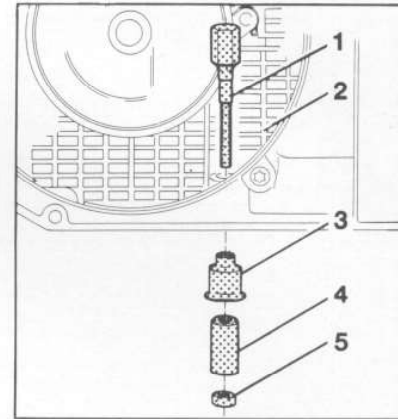

- Grip the rope **close** to the rotor and use it to turn the rope rotor three full turns clockwise.
- Hold the rope rotor steady.
- Pull out rope with starter grip and straighten it out.
- Hold the starter grip firmly to keep the rope tensioned.
- Let go of the rope rotor and slowly release the starter grip.

**Note:** The rewind spring is correctly tensioned when the starter grip sits firmly in the rope guide bush without drooping to one side. If this is not the case, tension the spring by one additional turn.

When the starter rope is fully extended it must still be possible to rotate the rope rotor at least another half turn before maximum spring tension is reached. If this is not the case, pull the rope out, hold the rope rotor steady and take off one turn of the rope.

**Do not overtension the rewind spring as this will cause it to break.**

The wear on the guide bush is accelerated by the starter rope being pulled sideways. The wall of the guide bush eventually wears through, becomes loose and has to be replaced.

- Remove the fan housing.
- Relieve tension on rewind spring, see 6.2, and remove the starter grip.
- Use a suitable tool to pry the old bush out of the fan housing.

To install the new rope bush:

- Place the new bush in its seat in the fan housing.
- Insert the screw spindle of the installing tool through the bush from inside the housing.
- Fit the thrust sleeve, tapered end first, and the hexagon nut.

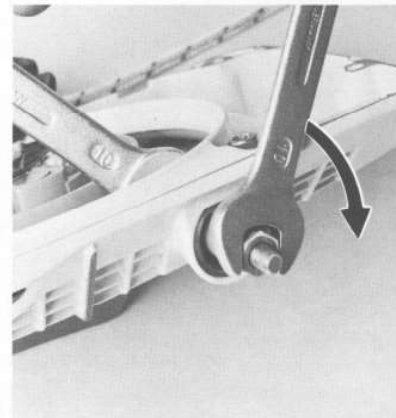

- Tighten down the hexagon nut until the bush is firmly seated.

**Note:** The installing tool flares the lower end of the rope bush.

- Refit the starter rope and the starter grip.
- Tension the rewind spring - see 6.5.
- Fit the fan housing.

## 7. AV HANDLE SYSTEM

### 7.1 Repair

Annular buffers and plugs at clutch side

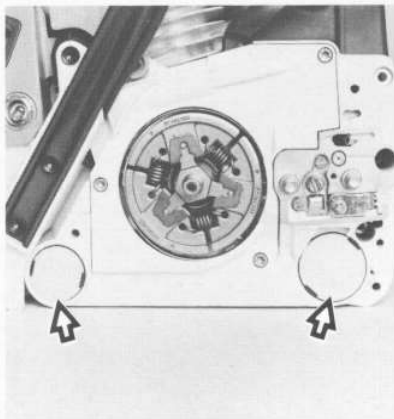

Annular buffers and plugs at ignition side

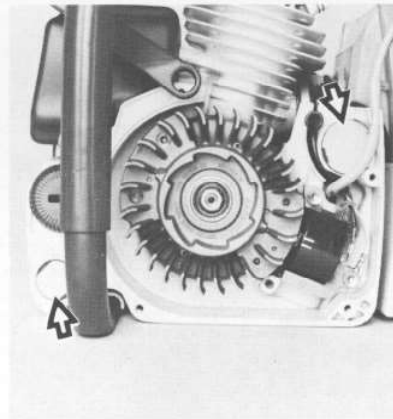

Rubber buffer on inboard side of crankcase

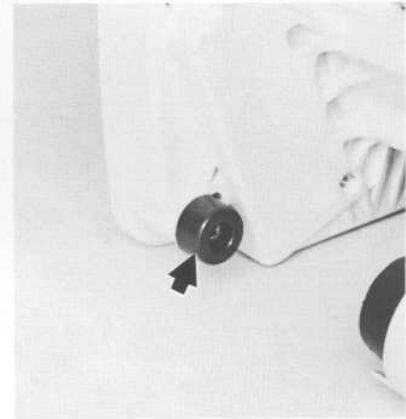

The crankcase and tank housing are connected by vibration damping rubber buffers. Damaged rubber buffers (annular buffers) must always be replaced.

Annular buffers must be replaced in sets of the same hardness (three degrees of hardness are available).

Harder buffers are installed for more accurate control but reduced vibration damping, while the softer buffers offer better vibration damping.

Removing annular buffers at clutch side:

- Remove chain sprocket cover, chain and bar.
- Take out the pan head screw and lift away the inner side plate.
- Pry out the plugs with a screwdriver.
- Unscrew the annular buffer mounting screws.
- Use a screwdriver to pry the annular buffers out of their seats.

**Note:** It is necessary to remove the tank housing, see 11.10, for access to the upper annular buffer.

Remove the upper annular buffer at the ignition side as follows:

- Remove the carburetor box cover.
  - Remove the air filter from the filter base.
  - Pull off the spark plug terminal.
  - Remove the shroud.
  - Remove fan housing.
  - Pry out the plug with a screwdriver.
  - Take out the mounting screw.
  - Use a screwdriver to pry the annular buffer out of its seat.
- No disassembly work is required to remove the lower annular buffer at the ignition side.
- Pry out the plug with a screwdriver.
  - Take out the mounting screw.

- Use a screwdriver to pry the annular buffer out of its seat.

**Note:** It is necessary to remove the tank housing, see 11.10, for access to the rubber buffer on the inboard side of the crankcase.

Installing new annular buffers:

- Position annular buffer, washer first, in crankcase seat.
- Insert the mounting screw and tighten it down firmly.
- Push the plug into the annular buffer.

**Note:** Coat front bead on plug with a little oil to ease installation.

Assembly is now a reversal of the disassembly sequence.

8. MASTER CONTROL

8.1 Construction and Function

Positions of Master Control lever:

- 1 = STOP
- 2 = RUN
- 3 = START (warm start)
- 4 = CHOKE (cold start)

Top:  
Cam serves as stop for Master Control lever and accommodates short circuit wire

Bottom:  
Lever in center of switch shaft locks throttle trigger in "Start" and "Choke" positions

Choke shutter closed by actuating lever on switch shaft

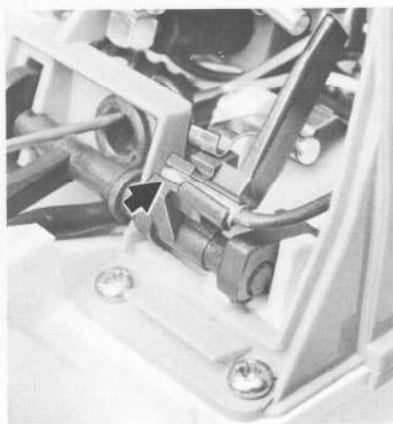
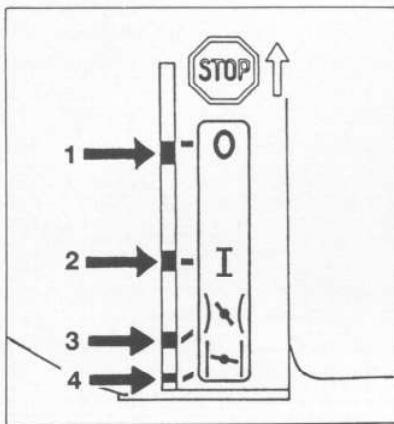

The main part of the Master Control is the switch shaft with an integrally molded multi-function operating lever and two levers.

The switch shaft is located forward of the rear handle in the tank housing and is supported at three points.

The thumb-operated Master Control lever moves the switch shaft to select the required function.

The following positions can be selected with the Master Control lever (from bottom upward):

- STOP (short circuit contact closed/ignition interrupted)
- RUN (normal operating position)

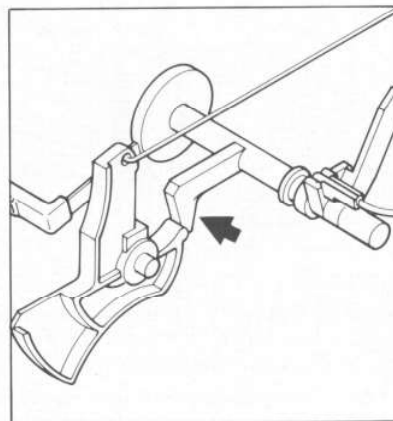

The short circuit wire's contact sleeve moves against the contact spring when the Master Control is set to "STOP".

The molded lever in the center of the switch shaft locks the throttle trigger in the "START" and "CHOKE" positions.

An actuating lever is molded to the right-hand end of the switch shaft. It closes the choke shutter when the Master Control lever is set to "CHOKE".

- CHOKE (cold start/choke shutter closed)
- START (warm start/choke shutter open)

The cam on the right holds the contact sleeve of the short circuit wire and is also the stop for locking the Master Control lever in the "CHOKE" and "RUN" positions.

8.2 Throttle Trigger/  
Interlock Lever

Top:  
Handle molding fastening screw  
on underside of rear handle

Bottom:  
Removing throttle interlock lever

Top:  
Detaching throttle rod

Bottom:  
Removing throttle trigger

1 = Throttle trigger  
2 = Torsion spring

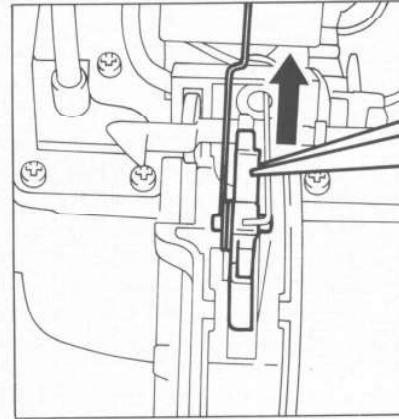
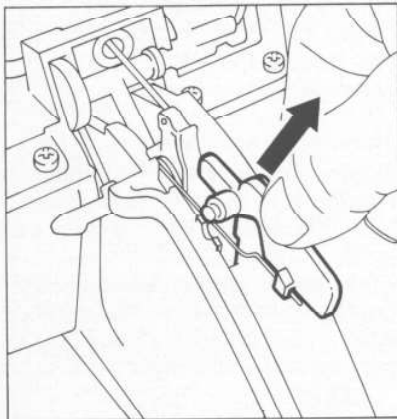
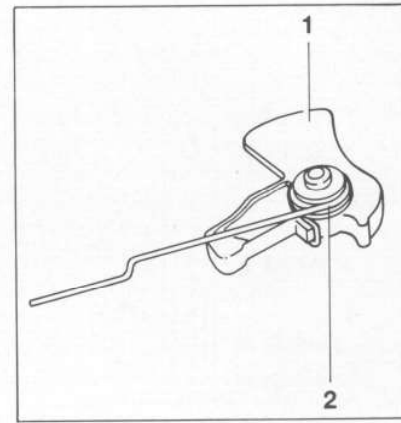
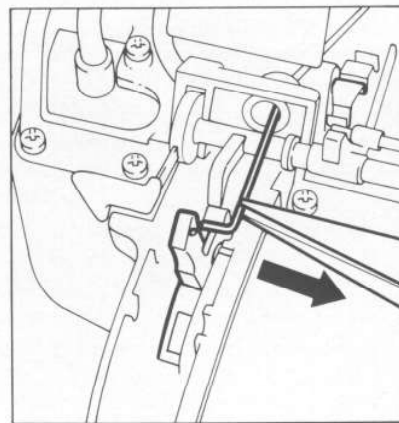
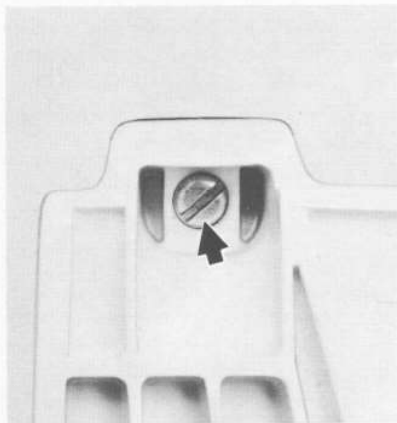

- Remove the torsion spring from the throttle trigger.

Installation is a reversal of the removal sequence.

**Note:** Pay special attention to the following points:

- Fit the torsion spring on the throttle trigger and position the trigger in its seat so that the hole for the throttle rod is at the top and the torsion spring points toward the Master Control lever.

- Fit the throttle rod and carefully move the Master Control down to "CHOKE" position.

- Fit the interlock lever.

**Note:** The torsion spring must be under the interlock lever and locate in the notch. The arm of the interlock lever must engage the throttle trigger.

- Remove the air filter - see 11.1.
- Move Master Control lever down to "CHOKE" position.
- Take out the handle molding fastening screw. Lift away the handle molding.
- Pull the throttle interlock lever out of its seat.

- Move Master Control lever to "RUN" position.
- Detach throttle rod from the trigger.
- Take the throttle trigger and torsion spring out of the handle.

8.3 Switch Shaft

Top:  
Removing short circuit wire

Bottom:  
Prying out switch shaft retainer

Top:  
Removing switch shaft

Bottom:  
1 = Throttle rod  
2 = Contact spring

Fitting retainer

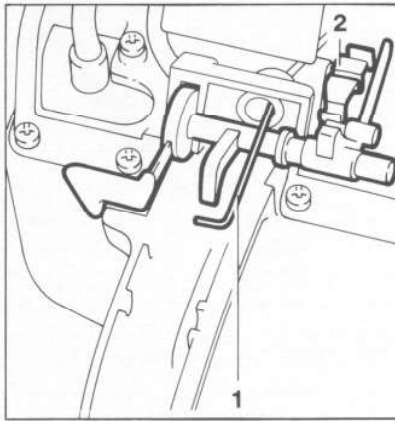
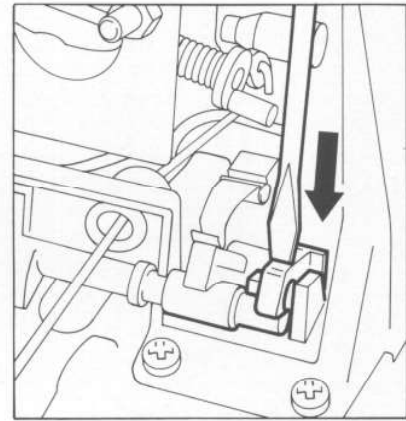
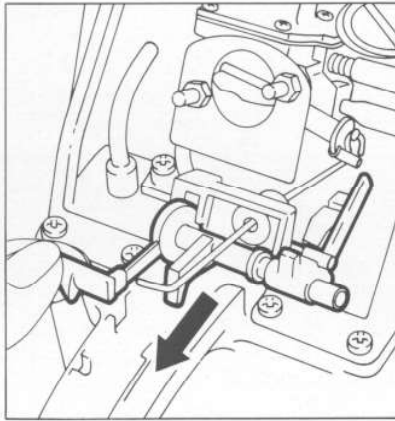
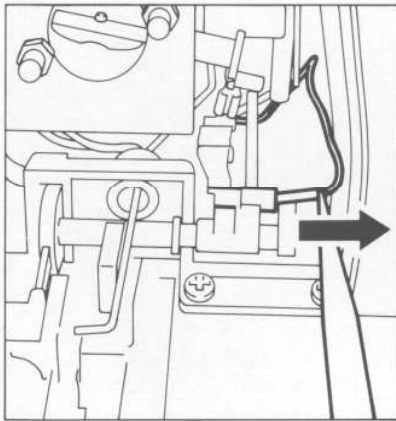

Place the retainer in position and press it down into the seat and over the switch shaft.

- Remove the throttle trigger/interlock lever - see 8.2.
- Pull the contact sleeve of the short circuit wire out of the switch shaft.
- Move the Master Control lever to the "RUN" position.
- Use a screwdriver to pry retainer and switch shaft out of right-hand seat.

- Take the switch shaft out of its pivot mounts.

Installation of the switch shaft is a reversal of the removal sequence.

**Note:** The Master Control lever must be in the "RUN" position when you install the switch shaft - the throttle rod must be above the switch shaft and the contact spring must locate on the cam for the short circuit wire.

9. ELECTRIC HANDLE HEATING SYSTEM

9.1 Troubleshooting

Top:  
Removing handle molding

Center:  
Plug connections  
1 = Generator wire  
2 = Wire to front handle heating element  
3 and 4 = Wires to rear handle heating element

Heating element in rear handle

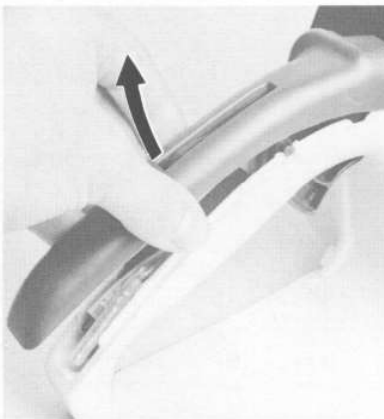
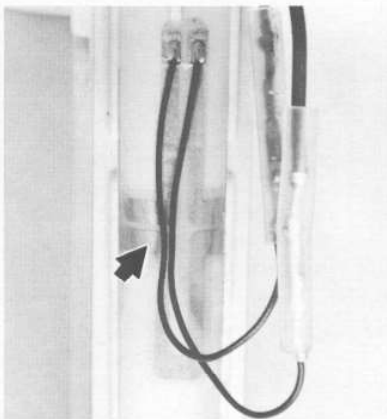

Heater switch on "I"



The entire handle heating system is maintenance-free and subject to practically no wear. Faults in the generator, heating elements and wiring are generally caused by mechanical damage from outside.

**Important:** The heating element in the rear handle may fail as a result of overheating if it is not bonded firmly in position without creases.

There are two reasons for failures in the heating system:

- A break in the circuit due to a faulty wire or component.
- A short circuit resulting from damage to the insulation.

To trace the cause of a fault:

- Remove the carburetor box cover, air filter and handle molding.
- Separate the plug connection of wires 1 and 3.

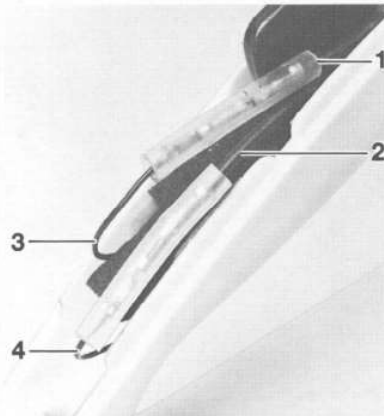

- Clip the ohmmeter test leads to wires 1 and 3.
- Set the heater switch to "I".

**Note:** All electrical components of the heating system are connected in series with the ohmmeter.

If the system is intact, the ohmmeter should indicate a value of around 2.5 Ω in measuring range "Ω x 1". If no reading is obtained, there is a break in the circuit. If the ohmmeter shows a value of less than 2.5 Ω, there is a short circuit in one of the components.

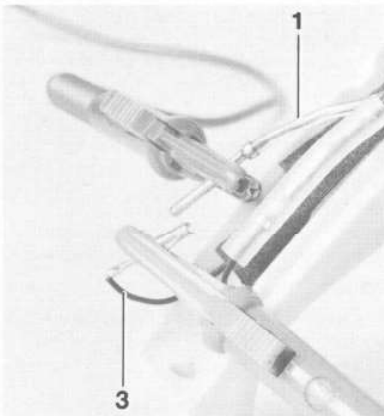

In either case it is necessary to check each component separately. The generator wire remains disconnected from the heating element during this check.

9.1.1 Troubleshooting Chart

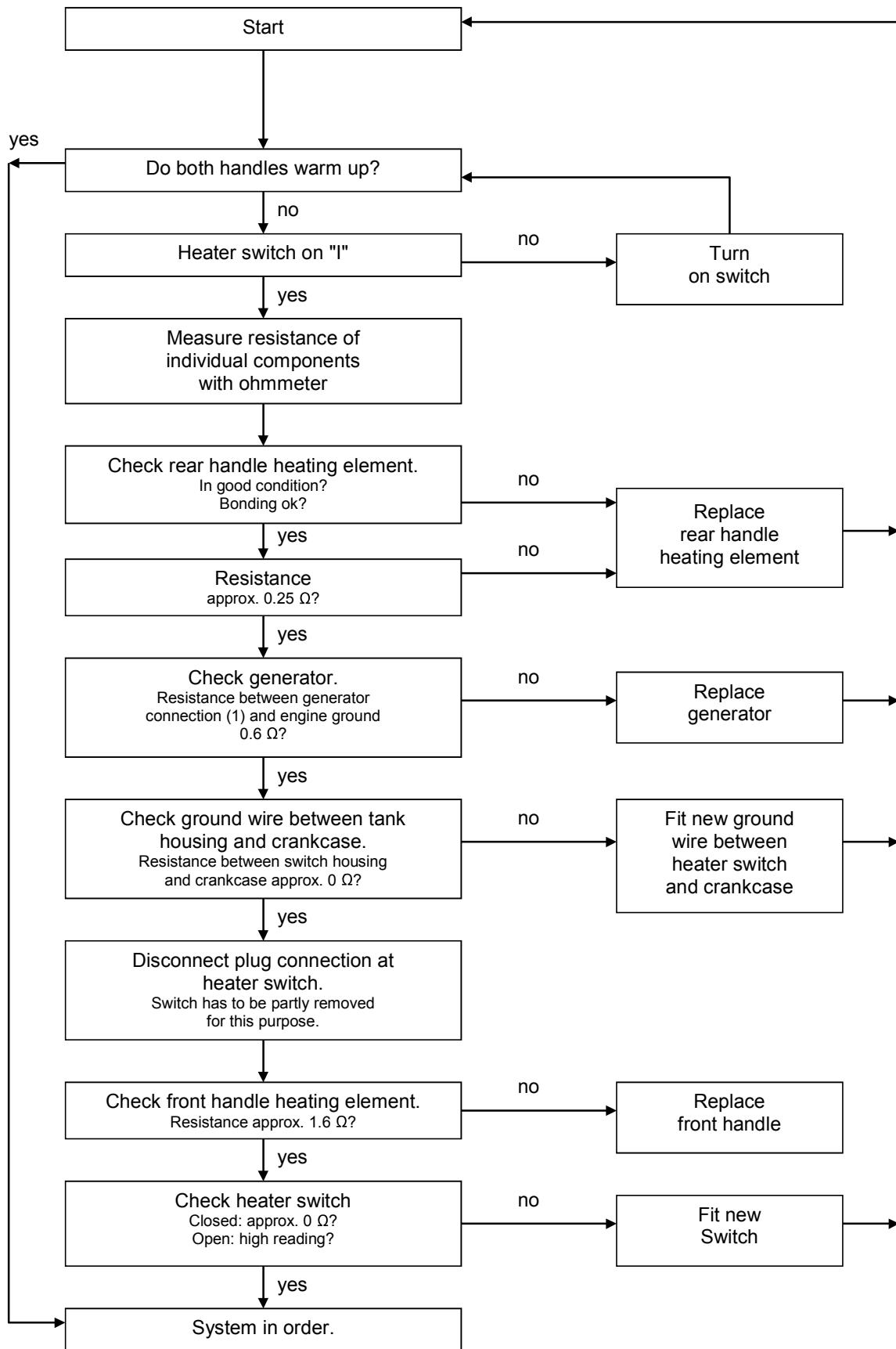

### 9.1.2 Test Connections and Test Values

The plug and socket connections of wires 1 to 4 must be disconnected to test the individual components.

Component	Ohmmeter connection (use either test lead)		Resistance $\Omega$		If faulty	
	Lead 1	Lead 2	Spec.	Actual (reading)	Cause	Remedy
Switch	Switch terminal <sup>1)</sup>	Ground	0	-	Switch faulty	Replace switch
Heating element in rear handle	Connector on wire 3	Connector on wire 4	0,25	approx. 0,25	Heating element OK	Replace heating element
				-	Break in wire, heating element damaged	
				0	Short circuit - damaged insulation	
Heating element in front handle	Connector on wire 2	Ground	1,6	approx. 1,6	Heating element OK	Replace front handle
				-	Break in wire, heating element damaged	
				0	Short circuit - damaged insulation	
Generator	Connector on wire 1	Ground	0.6	approx. 0.6	Generator OK	Replace generator
				-	Break in wire, generator damaged	
				0	Short circuit - damaged insulation	

<sup>1)</sup> Remove wire for this purpose

## 9.2 Switch

Withdrawing contact sleeve

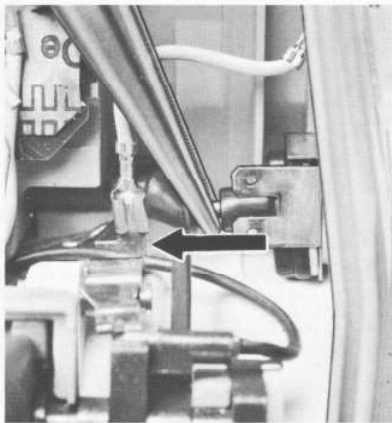

- 1 = Grommet  
 2 = Switch  
 3 = Twin connector tag  
 4 = Ring  
 5 = Hexagon nut

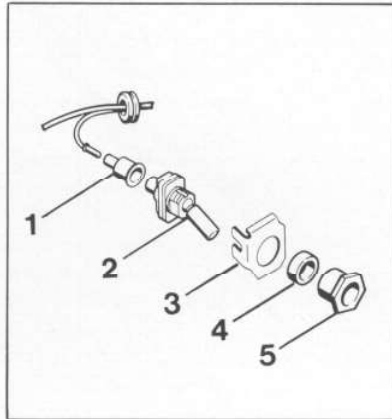

To remove the switch:

- Remove the carburetor box cover, air filter and filter base.
- Remove the carburetor - see 11.4.
- Take the two ground wire terminals off the twin connector tag.
- Push the grommet back a little and use pliers to pull the wire's contact sleeve out of the switch.
- Unscrew the switch mounting nut (14 mm socket wrench).
- Remove the switch from inside the carburetor box.
- Remove the ring and twin connector tag from the switch.

Fit the new switch:

- Slip the twin connector tag and ring over the switch's thread.
- Install the switch from inside the carburetor box (tank housing).

**Note:** The two connector tags must face forward.

- Fit the hexagon nut from outside and tighten in down.
- Use pointed nose pliers to push the contact sleeve into the switch.
- Push the grommet over the switch.
- Connect the two ground wires to the twin connector tag.

Assembly is now a reversal of the disassembly sequence.

## 9.3 Heating Element in Rear Handle

Plug connections in rear handle

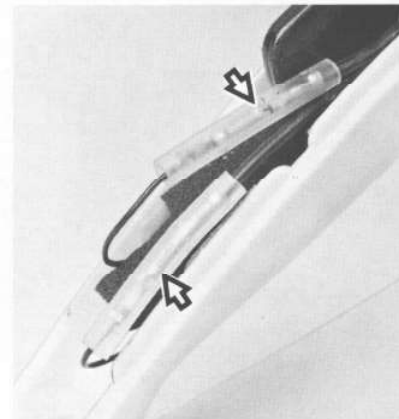

To replace the heating element, first remove the carburetor box cover and handle molding - see 8.2.

- Separate the plug connection of the handle heating system.
- Take the pressure pad and heating element out of the handle recess.

**Important:** Before fitting the new heating element, clean the surface inside the handle so that it is free from grease, dirt and moisture.

- Remove the backing paper from the new heating element.
- Press the heating element firmly and uniformly into position, taking special care at the corners and along the edges.

**Important:** Creases must be avoided. If the heating element is not fitted perfectly flat, heat transfer will be interrupted and the element may fail as a result of overheating. The ambient temperature during installation should not be less than +15 °C (60 °F).

9.4 Heating Element in Front Handle

Fitting pressure pad



Plug connections  
2 = Wire to front handle heating element  
4 = Wire to rear handle heating element

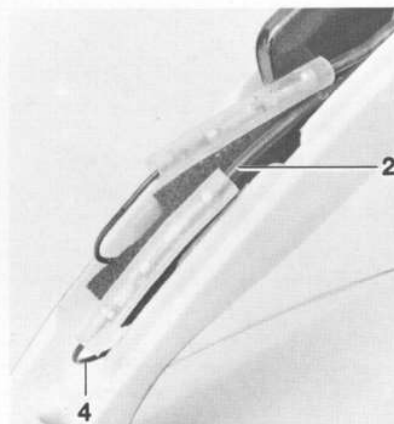

Top:  
Ground wires on switch's twin connector tag

Bottom:  
Pushing back grommet to expose contact sleeve

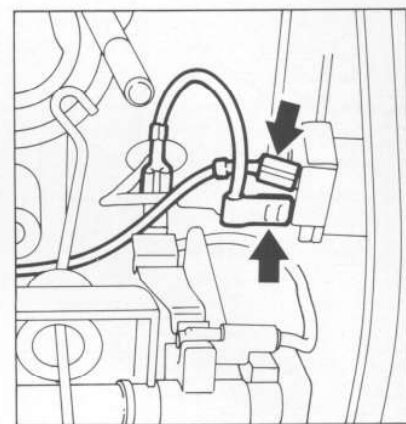

- Fit a new expanded rubber pressure pad on top of the heating element. The heating element must be completely covered.
- Reconnect the two wires (do not forget the insulating tube).
- Refit the handle molding and carburetor box cover.

To check operation of heating element:

- Run the saw at maximum revs for no more than 30 seconds with the heating switched on.

**Note:** The heat generated during this process also helps the element's adhesive set faster.

The heating element in the front handle (handlebar) is not replaceable. A new handle must be fitted if the heating element is faulty.

To replace the front handle, remove the following parts:

- Carburetor box cover
- Air filter with filter base
- Carburetor
- Handle molding

**Note:** The following operations are easier if the throttle rod is disconnected from the throttle trigger and the switch shaft is taken out of its pivot. The short circuit wire can be left on the switch shaft.

- Disconnect wires 2 and 4 and use the assembly hook to pull wire 2 into the carburetor box through the insulating tube and grommet.

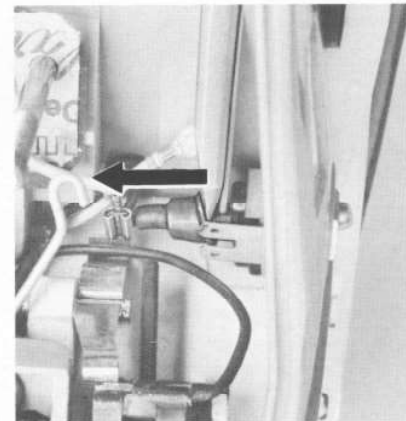

- Remove the ground wire terminals from the twin connector tag on the switch.
- Push the rubber grommet back a little on the connecting wire and use pliers to pull the contact sleeve out of the switch.
- Slip the rubber grommet off the connecting wire.

9.5 Generator

Top and center:  
Front handle mounting screws

Bottom:  
Wires threaded through grommet  
in carburetor box

Wires correctly positioned in rear  
handle recess

1 = Insulating tube  
2 = Male connector  
3 = Female connector

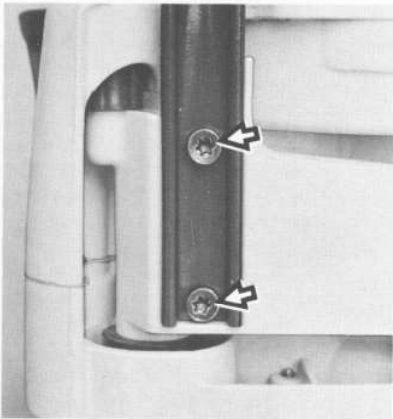
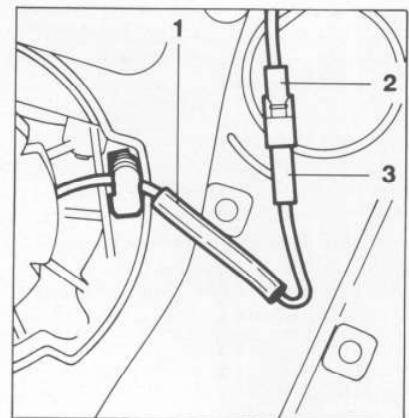
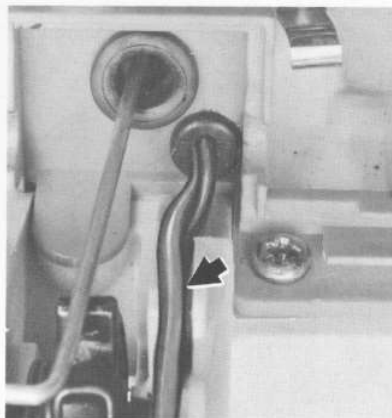
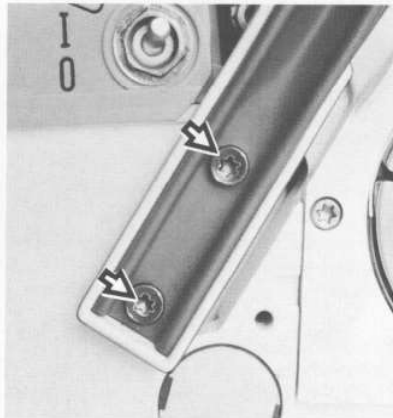

- Take out the four screws and remove the front handle.
- Important:** The special screws used for polymer joints are secured with Loctite. Always heat the screwed joint before loosening, e.g. with a hair dryer. Take care not to overheat the polymer.
- Pull both wires through the grommet and out of the carburetor box.

Reverse the above sequence to fit the new front handle.

**Note:** Secure the handle mounting screws with Loctite - see 12.2.

Check that wire 2 of the front handle heating element and the generator wire 1 are properly positioned in the rear handle.

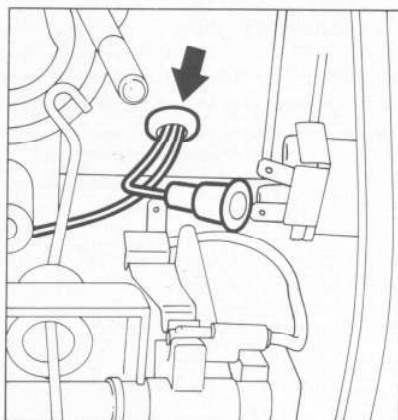

- Remove the air filter - see 11.1.
- Remove the shroud - see 3.2.
- Remove the flywheel - see 5.1.5.
- Remove the ignition module - see 5.1.6.2.
- On 066, pull the male connector out of the female connector.
- Use a small screwdriver to press down the anchor hook of the terminal pin and then pull off the pin housing.
- Pull the insulating tube off the connecting wire.

**Note:** Removal of the generator is the same as for the 064. The disconnection of the electrical wires, as described below, is only necessary on the 064.

- Take the switch shaft out of its pivot mounts - see 8.3.

Top:  
Front grommet in carburetor box

Bottom:  
Withdrawing generator connecting  
wire in direction of rear grommet

Top:  
Pushing grommet out of crankcase wall

Center:  
Rear grommet in carburetor box

Bottom:  
Generator mounting screws

Pulling wire retainer out of crankcase

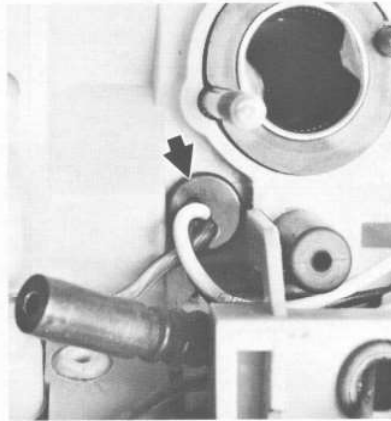
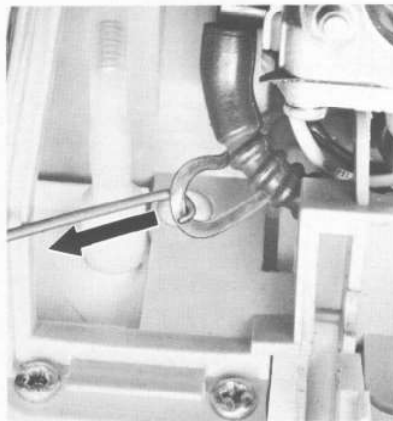
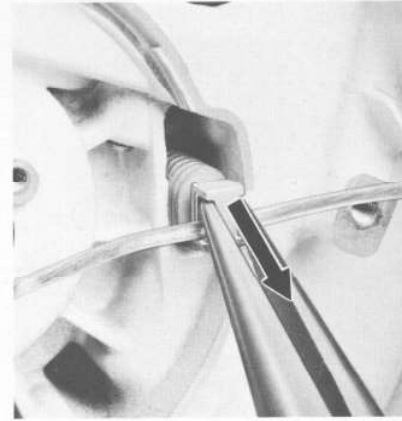
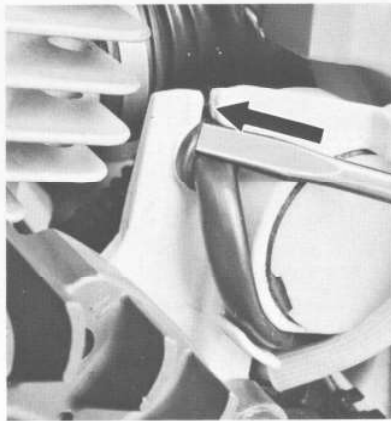
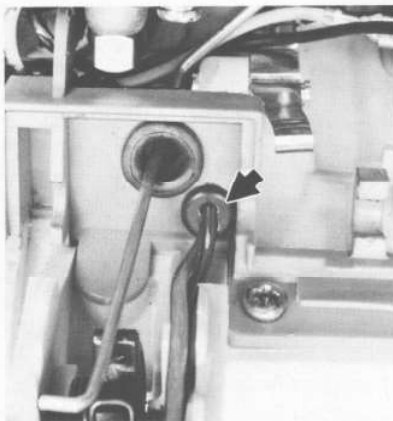

- Use a blunt screwdriver to push the lateral grommet out of the crankcase wall (from outside).
- Take the insulating tube and wires out of the two retainers on the crankcase.
- Use a blunt tool to push the rear grommet out of the carburetor box in the direction of the cylinder.

**Note:** This job is easier if the carburetor is removed - see 1 1.4.

- Remove the three generator mounting screws.

**Note:** The screws are secured with Loctite and may be difficult to remove.

- Pull terminal pin of generator wire 1 in rear handle out of the socket.
- Pull generator wire 1 through the insulating tube and front grommet.
- Use the assembly hook to pull generator wire 1 through the carburetor box in the direction of the rear grommet.

- Lift the generator away.
- Use pliers to pull the wire retainer out of the crankcase.
- Pull generator wire 1 out of the rear grommet, through the insulating tube and the retainer.

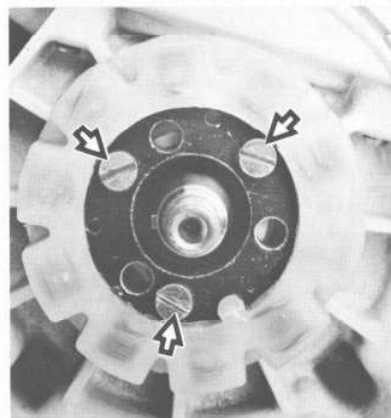

Top:  
Generator wire in rear grommet (1),  
insulating tube (2) and retainer (3)

Center:  
Centering tool 1118 893 3500 in  
position

Bottom:  
Removing centering tool with  
puller 1107 890 4500

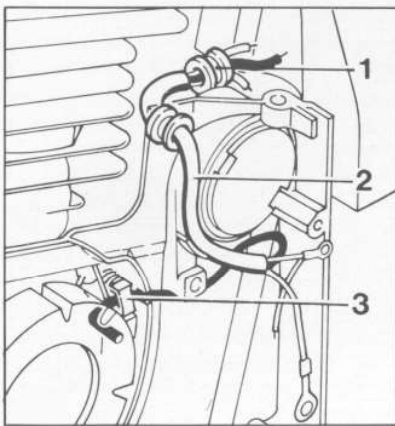

**Installing the generator:**

- On 066, slip the insulating tube over the generator connecting wire, slide the pin housing onto the terminal pin until it engages and then push the male connector into the female connector.

**Note:** Installation of the generator is the same as for the 064. Fitting the electrical wires, as described below, is only necessary on the 064.

- Thread the generator wire through the retainer, the insulating tube and the rear grommet.
- Place generator in position on the three mounting bosses.
- Coat threads of mounting screws with Loctite, see 12.2, fit them in the generator and tighten down moderately.
- Fit the centering tool on the crankshaft so that its groove engages the Woodruff key.
- Finally tighten the three mounting screws to a torque load of 2 Nm (1.5 lbf.ft).
- Remove the centering tool. If necessary, use puller to remove the centering tool from the crankshaft.
- Push the retainer into the crankcase.

**Note:** The generator connecting wire must be positioned in the crankcase recess and below the mounting boss for the upper ignition module screw.

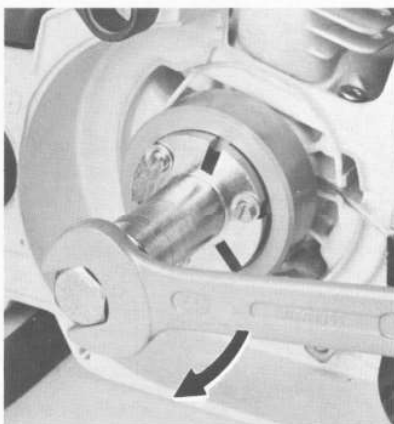
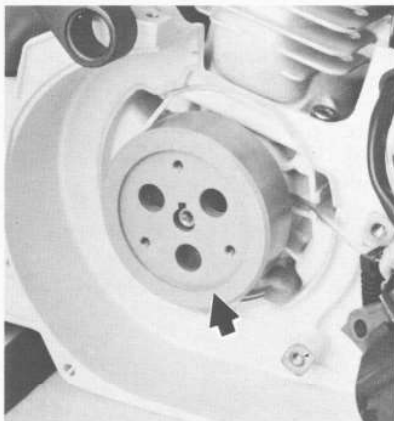

Top:  
Position of generator connecting  
wire in crankcase recess and below  
upper ignition module mounting boss  
1 = Seat of retainer in crankcase

Bottom:  
Position of generator connecting  
wire below fuel line and below the  
throttle rod

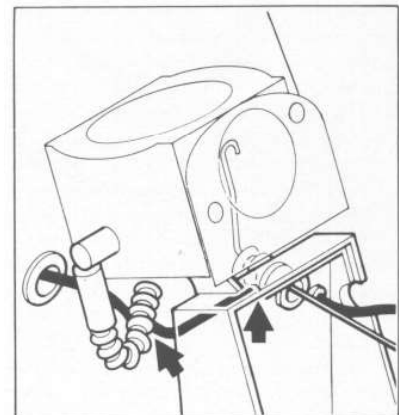
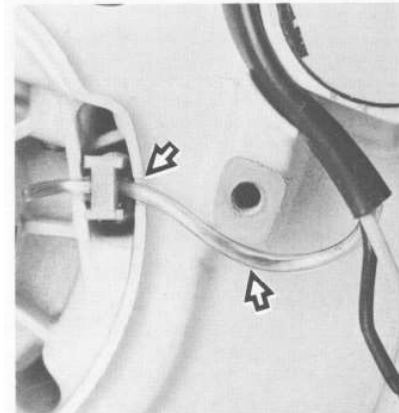

On the 066, the insulating tube must butt against the crankcase recess

Assembly is now a reversal of the disassembly sequence.

Make sure the generator connecting wire is located below the fuel line and below the throttle rod.

10. CHAIN LUBRICATION

10.1 Pickup Body

Top:  
Oil tank filler cap

Bottom:  
Assembly hook 5910 893 8800

Top:  
Withdrawing pickup body

Bottom:  
Pulling pickup body out of hose

Top:  
Disconnecting the strainer

Bottom:  
1 = Hose  
2 = Connector  
3 = Strainer

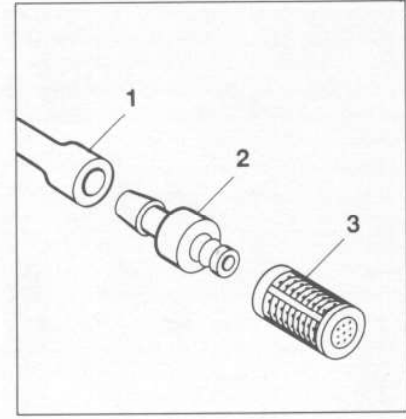
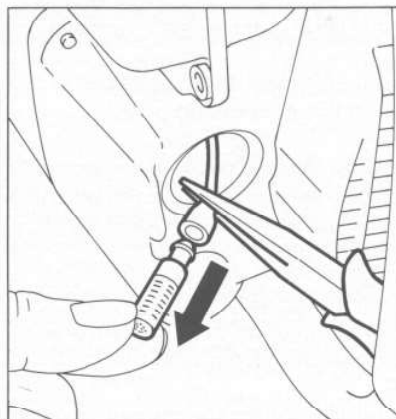
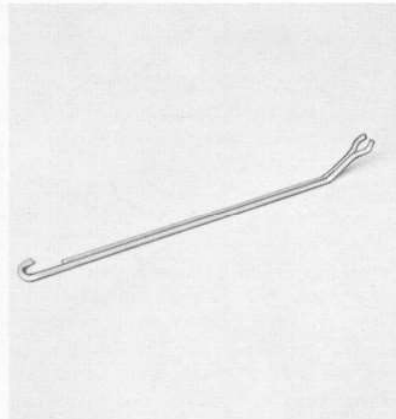
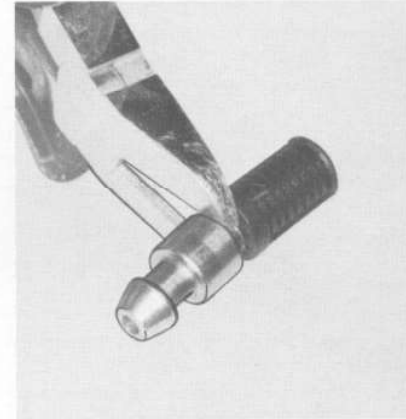
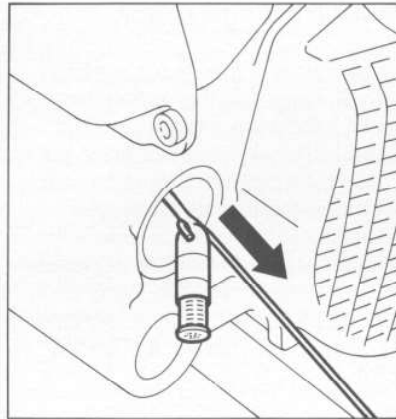
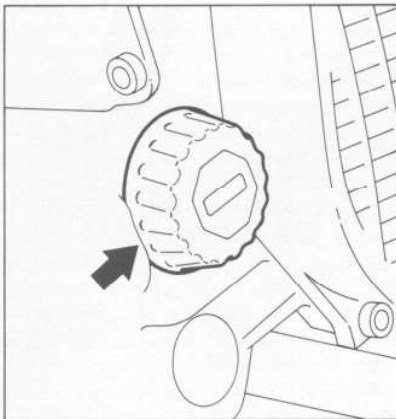

Impurities gradually clog the fine pores of the filter with tiny particles of dirt. This prevents the oil pump from supplying sufficient oil to the bar and chain. In the event of problems with the oil supply, first check the oil tank and the pickup body. Clean the oil tank if necessary.

- Remove the oil filler cap together with the cap retainer.
- Drain the oil tank.

- Use assembly hook to withdraw the pickup body from the oil tank.

**Note:** Do not stretch the oil hose too much when withdrawing the pickup body.

- Hold the oil hose steady and pull out the pickup body.

- Use side cutters or similar tool to remove the strainer from the connector.

- Wash the strainer and pickup body in white spirit and, if possible, blow out with compressed air.

- Flush out the oil tank.

Reassemble by reversing the disassembly sequence.

**Important:** Always replace any damaged parts.

## 10.2 Suction Hose

Top:  
Withdrawing the suction hose

Bottom:  
Correct position of suction hose

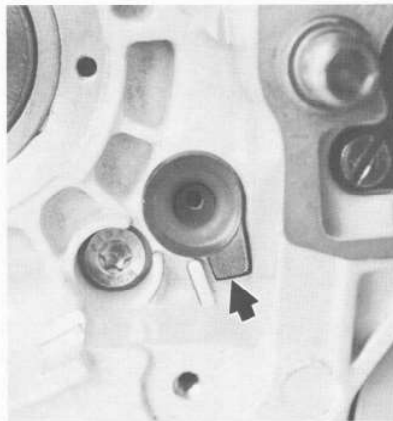
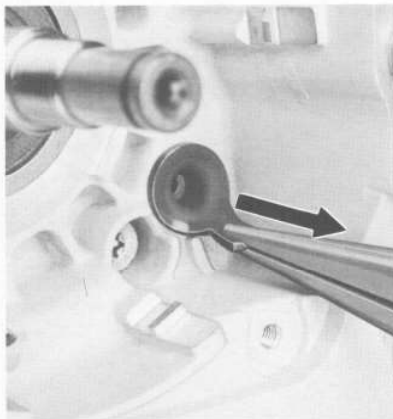

- Remove the oil pump - see 10.4.
- Use pointed nose pliers to grip the tab of the oil hose and pull it out of the crankcase.
- Pull off the pickup body - see 10.1.
- Fit the pickup body - see 10.1.
- Use a blunt tool to push the suction hose into the crankcase so that the tab locates it its seat at the bottom right.
- Install the oil pump - see 10.4.

## 10.3 Vent Valve

Top:  
Vent valve

Bottom:  
Installed position of valve  
a = approx. 1 mm (3/64")

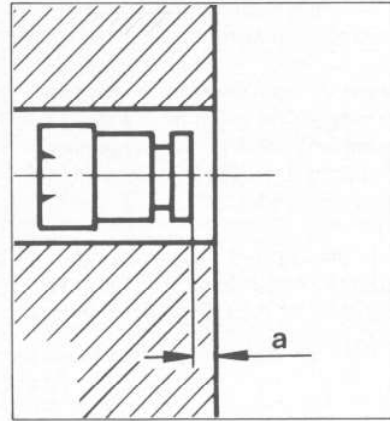
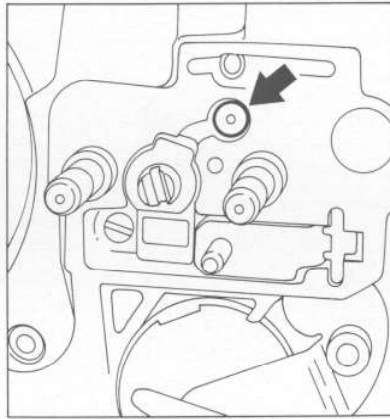

- There is vent valve in the tank wall which keeps the internal pressure in the oil tank equal to atmospheric pressure.
- Remove the inner side plate.
  - Drain the oil tank.
  - Use a 7 mm (9/32") dia. drift to carefully drive the vent valve into the crankcase and then remove it from the oil tank.
  - Carefully press in the new valve until it is about 1 mm (3/64") below the face of the crankcase.
  - Refit the inner side plate.

## 10.4 Removal and Installation of Oil Pump

Top:  
Removing worm with spring

Bottom:  
1 = Worm with original spring  
2 = Worm with new spring

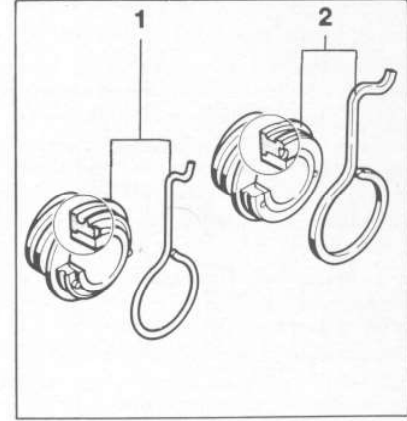
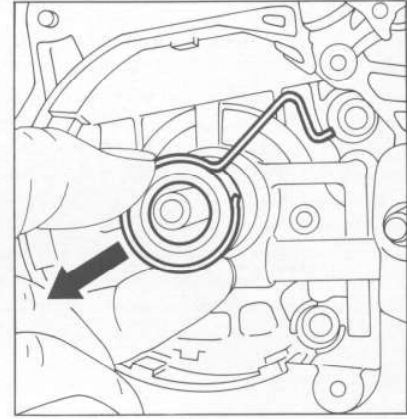

- Remove the brake band - see 3.3.1.
- Remove the clutch - see 3.2.
- Rotate the worm and spring clockwise and pull them off the crankshaft stub.

**Note:** The spring and worm have been modified. Original versions of these parts cannot be combined with the new versions.

Top:  
Oil pump mounting screws (066)

Bottom:  
1 = Oil pump mounting screws (064)  
2 = Oil delivery hose  
3 = Sleeve

Sealing ring in crankcase bore (066)

New oil flow control symbol with  
E-(=Ematic)mark

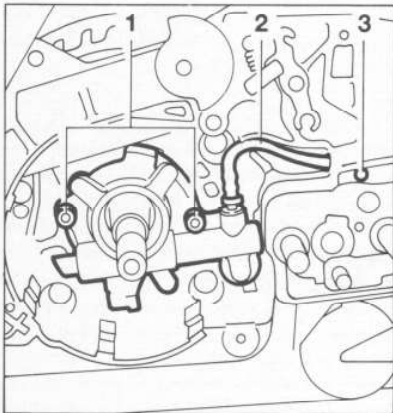
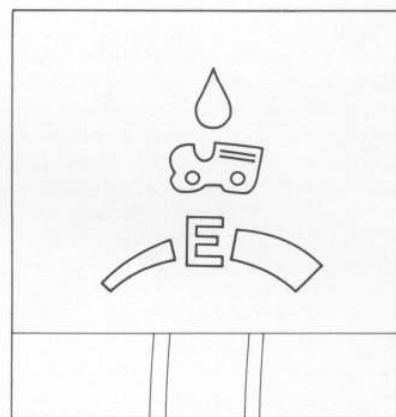
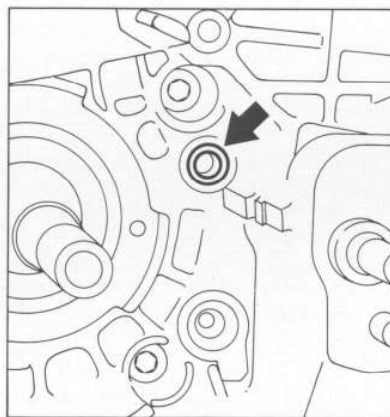
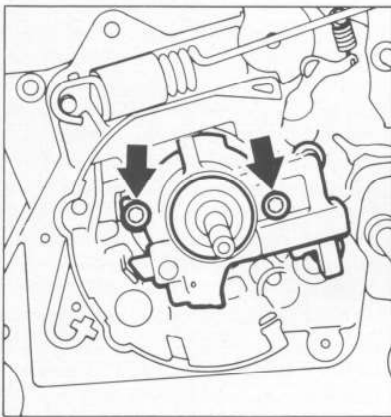

- Take the sealing ring out of the crankcase bore.

**Note:** A new oil pump is installed in model 064 saws from machine number X 20 361 348. This new oil pump can also be installed in older machines.

The adjustment range of the oil quantity control bolt has been reduced from 270 degrees (2 turns) to 90 degrees (1/4 turn).

Setting the oil pump to the Ematic position "E" is the most economic position under normal operating conditions using a STIHL Ematic guide bar.

Installation is a reversal of the removal sequence.

**Note:** Pay special attention to the following points:

- Take out the oil pump mounting screws and remove the oil pump.

**Note:** On the 064 the oil delivery hose has to be pulled off the oil pump. For removal of the oil delivery hose it is necessary to press out the sleeve in the bar mounting flange. The hose is damaged in this process and must be replaced.

10.5 Servicing the Oil Pump

Component parts of oil pump (066)

- 1 = Plug
- 2 = Pump piston
- 3 = Washer
- 4 = Helical spring
- 5 = Pump housing
- 6 = Spring pin
- 7 = O-ring
- 8 = Control bolt

Modified flat nosed pliers  
a = 5.5 mm (7/32")

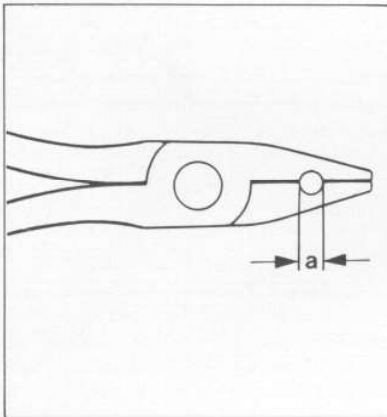

Modified carburetor screwdriver  
0000 890 2300  
b = R 1.5 mm (1 /16")

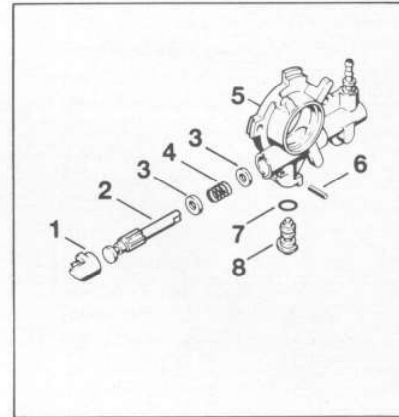
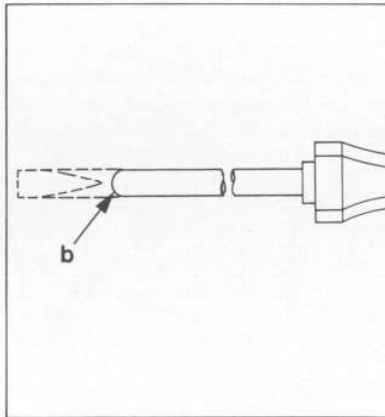

- Tighten mounting screws to 3.0 Nm (2.2 lbf.ft).

Installing oil delivery hose (064):

- Cut new oil delivery hose to a length of 74 mm (2.9 in) and coat ends with oil. Use modified flat nosed pliers (see illustration) to fit the oil delivery hose on the oil pump nipple.
- Push the oil delivery hose through the bore in the bar mounting flange (from the inside outwards) and allow it to project about 10-20 mm (1/64" - 1/32"). If the hose cannot be pushed through on older machines, drill out the bore to a diameter of 6.2 mm and deburr carefully.

- Hold the projecting end with the modified flat nosed pliers. Now push home the sleeve with the modified carburetor screwdriver.
- Place oil pump in installed position. Use modified carburetor screwdriver to push hose into bar mounting flange so that it is recessed about 1-2 mm (3/64" - 5/64").

Always check the suction hose and pickup body before disassembling the oil pump.

- Remove the oil pump - see 10.4.
- Use a 2 mm (5/64") dia. drift to drive out the spring pin. Pull the control bolt out of the housing and remove the O-ring.

**Note:** The original pump has an adjusting screw which must be unscrewed clockwise.

- Pry the plug out of the housing and withdraw the pump piston with helical spring and washers.
- Wash all parts in white spirit. Inspect the parts for damage and replace as necessary.

Assembly is a reversal of the disassembly sequence.

**Note:** Always install a new O-ring. Coat the pump piston and worm with grease, see 12.2, before installing.

11. FUEL SYSTEM

11.1 Air Filter

- 1 = Carburetor box cover
- 2 = Twist lock
- 3 = Master Control lever

Top:  
Removing outer filter element

- Bottom:  
1 = Inner filter element  
2 = Slotted nuts  
3 = Baffle

Top:  
Open connector on inner filter element

Bottom:  
O-ring on baffle

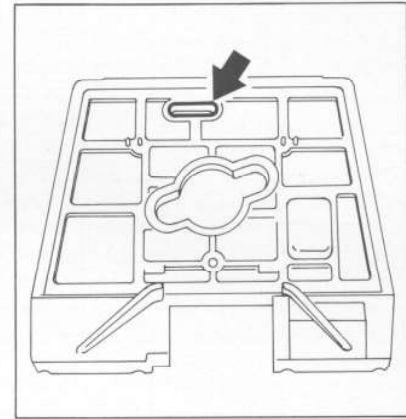
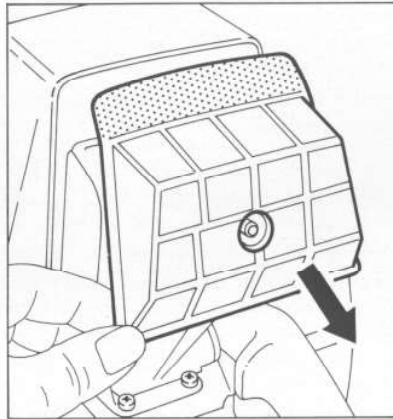
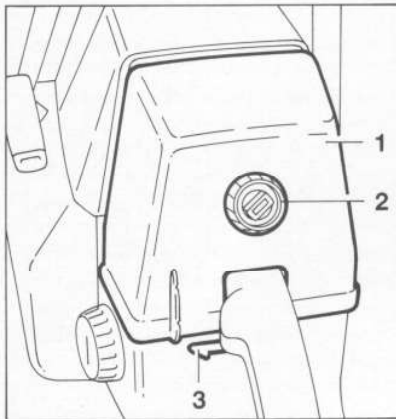

The air filter's function is to remove dust and dirt sucked in with the combustion air and thus help reduce wear on engine components to a minimum.

Dirty and clogged air filters reduce engine power, increase fuel consumption and make starting more difficult.

**The air filter should always be cleaned when engine power begins to drop off.**

In machines with digital ignition the carburetor with compensator keeps the fuel content in the mixture constant at all times, irrespective of how dirty the filter is - see also 11.2.

- Before removing the air filter, close the choke shutter to prevent dirt falling into the carburetor.
- Take off the carburetor box cover.

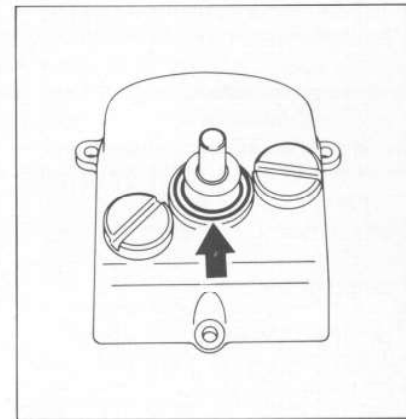
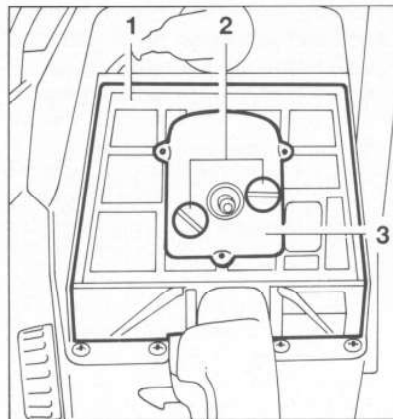

- Pull off the outer filter element.
- Remove the slotted nuts and pull away the baffle and inner filter element.
- Thoroughly wash the two elements in a fresh, non-inflammable cleaning solution (e.g. warm soapy water). Carefully shake dry. Encrusted dirt should be softened by immersing the filter in the cleaning solution.

**Note:** If the filter fabric is damaged, replace the part concerned immediately.

Installation is a reversal of the removal sequence.

**Note:** Only inner filter elements with an open connector may be installed in models with compensator carburetors. Fit a new O-ring on the stub of the baffle.

## 11.2 Construction and Operation of Carburetor with Compensator

Carburetor without compensator  
 $P_i$  = Internal pressure  
 $P_a$  = Atmospheric pressure  
 $P_r$  = Pressure in metering chamber  
 1 = Box-type filter

Carburetor with compensator  
 $P_i$  = Internal pressure  
 $P_a$  = Atmospheric pressure  
 $P_r$  = Pressure in metering chamber  
 1 = Compensator  
 2 = Box-type filter

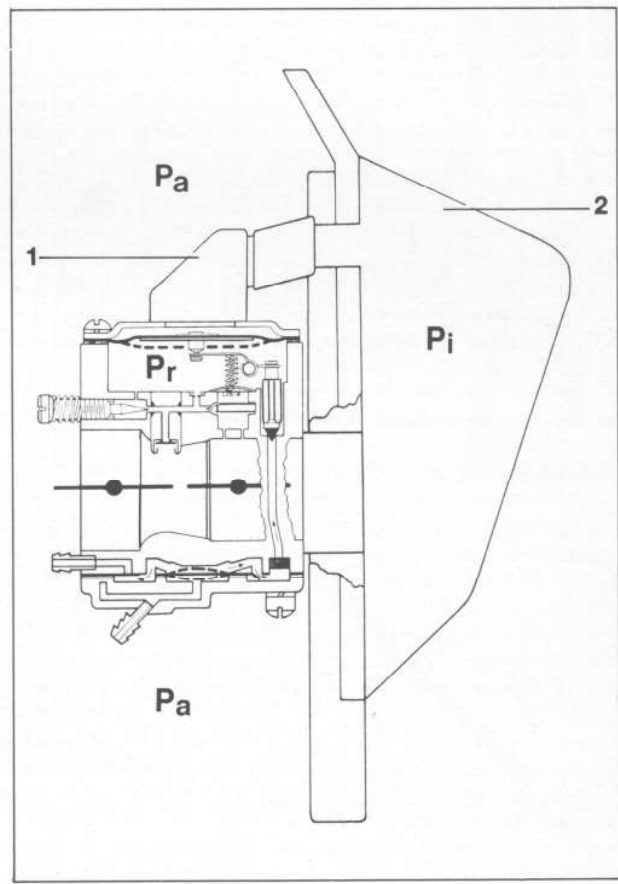
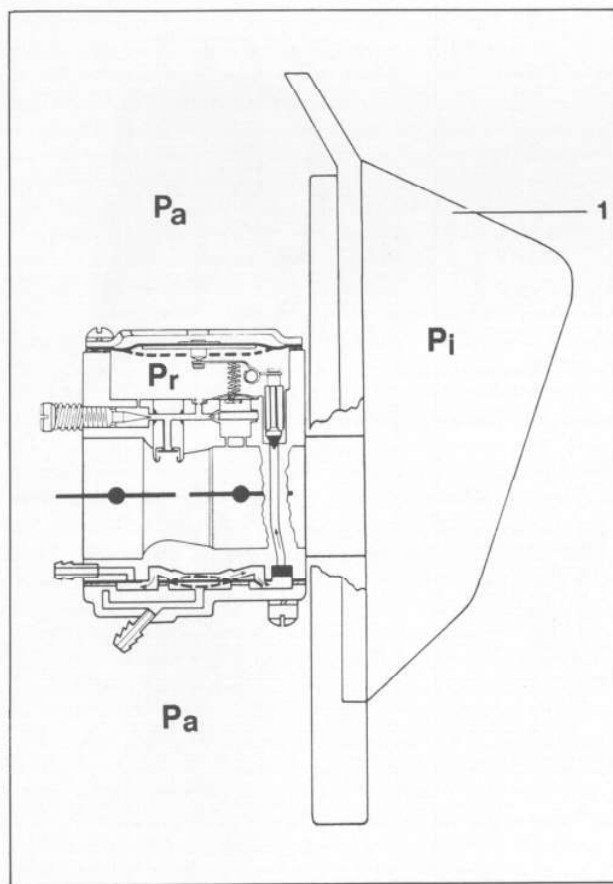

The compensator carburetor keeps the fuel content in the mixture constant at all times, irrespective of how dirty the air filter is. The pressures at the clean air side of the air filter and the metering diaphragm are always equal.

The end cover of the new carburetor, the rear half of the air filter each have an integrally molded connector.

A sleeve is fitted between the end cover and air filter.

The air volume is reduced when the air filter is dirty. This not only increases the depression in the carburetor's venturi, but also decreases the pressure applied to the outside of the metering diaphragm. The metering diaphragm moves upward, causing the needle valve to close part-way and thus reduce the supply of fuel.

The mixture cannot become over-rich. And it is no longer necessary to alter the setting of the high speed adjusting screw as contamination of the air filter increases. However, engine performance drops due to the reduction in air volume and can only be restored to normal by cleaning the air filter.

### 11.3 Leakage Testing the Carburetor

Top:  
Fuel line fitted on elbow connector

Bottom:  
Fuel line 1110 141 8600 fitted  
on nipple 0000 855 9200

Top:  
Tester's fuel line fitted on  
elbow connector

Bottom:  
Nipple connected to pressure hose

Top:  
Pressure testing carburetor  
with carburetor crankcase tester  
1106 850 2905

Bottom:  
Damaged inlet needle

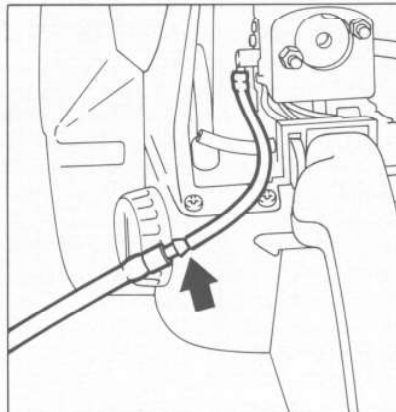
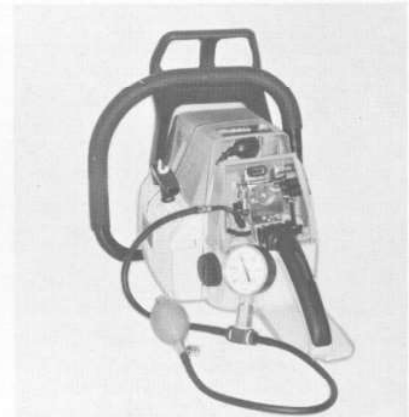
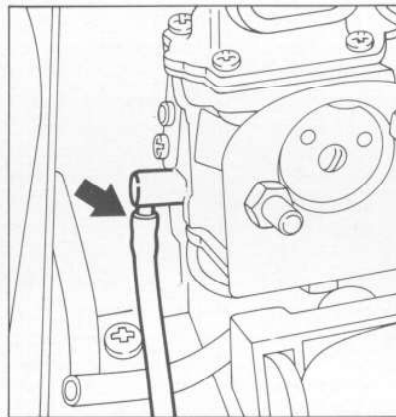
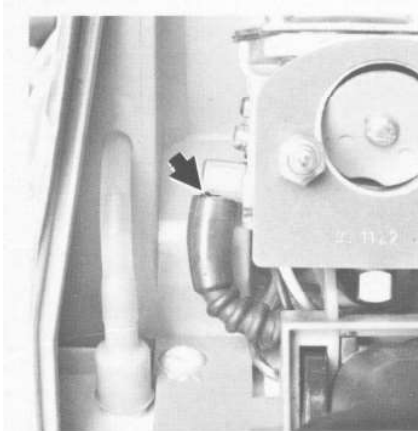

Troubleshooting chart - see 2.4.

The carburetor can be tested for leaks with the carburetor and crankcase tester.

- Remove the air filter - see 11.1.
- Pull fuel hose off carburetor's elbow connector.

- Push fuel line with nipple onto the elbow connector. Connect nipple to tester's pressure hose.

- Close the vent screw on the rubber bulb and pump air into the carburetor until the pressure gauge shows a reading of approx. 0.4 bar (5.7 psi).

If this pressure remains constant, the carburetor is airtight. However, if it drops, there are two possible causes:

1. The inlet needle is not sealing (foreign matter in valve seat or sealing cone of inlet needle is damaged or inlet control lever sticking).
2. The metering diaphragm is damaged.

In either of these cases the carburetor must be removed and serviced - see 11.5.

### 11.4 Removal and Installation of Carburetor

Top:  
Prying out lateral grommet

Bottom:  
Disconnecting fuel hose from elbow connector

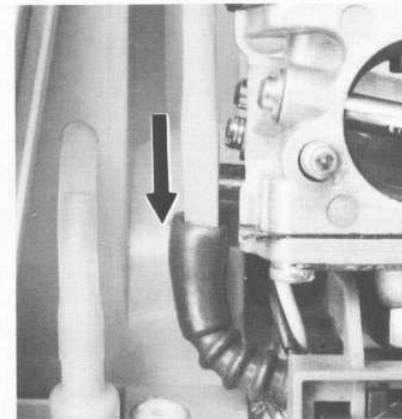
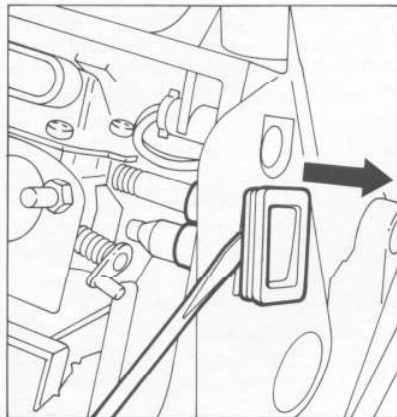

Top:  
1 = Mounting nuts  
2 = Baffle plate

Bottom:  
Disconnecting the throttle rod

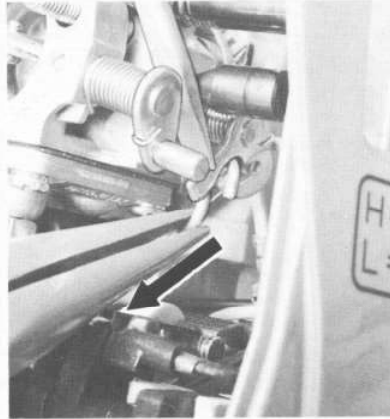
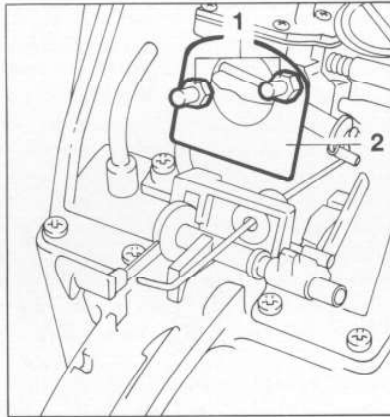

Removing carburetor

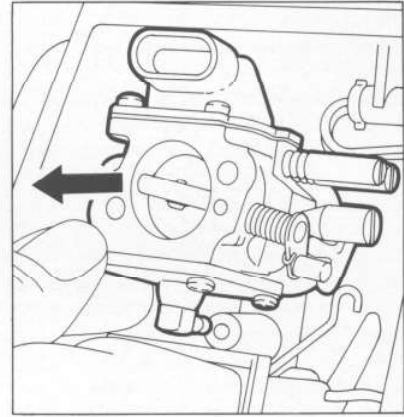

- Use a screwdriver to press down the throttle shaft lever and, at the same time, detach the throttle rod with pointed nose pliers.
- Pull the carburetor off the studs - the elbow connector slips out of the impulse hose at the same time.

The all-position diaphragm carburetor consists of a fuel pump and the actual carburetor. Although the fuel pump shares a common housing with the carburetor, it operates as a completely separate and independent unit.

Troubleshooting chart - see 2.6.

- Remove the air filter - see 11.1.
- Pry the lateral grommet off the adjusting screws and out of the carburetor box.
- Disconnect the fuel hose from the carburetor's elbow connector.
- Unscrew the carburetor mounting nuts.
- Pull the baffle off the studs.

### 11.5 Servicing the Carburetor

Top:  
1 = Washer  
2 = Sleeve

Bottom:  
Elbow connector in impulse hose

Top:  
Fuel pump end cover fastening screws

Bottom:  
1 = End cover  
2 = Gasket  
3 = Pump diaphragm

Prying out fuel strainer

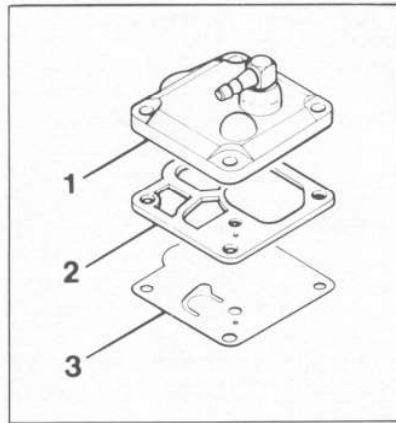
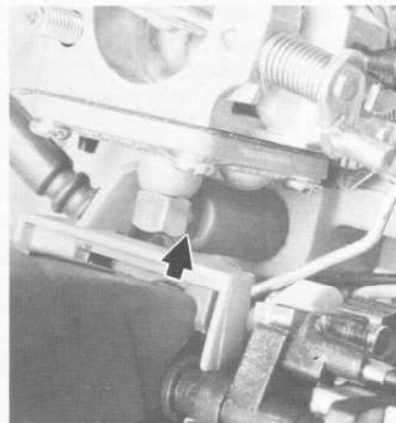
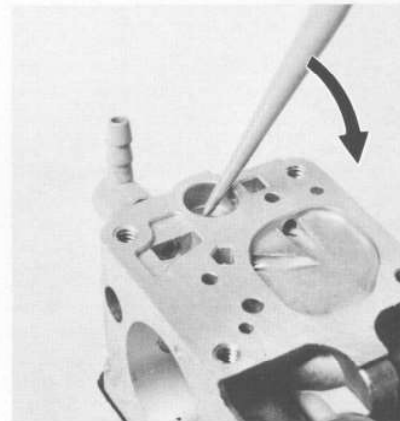
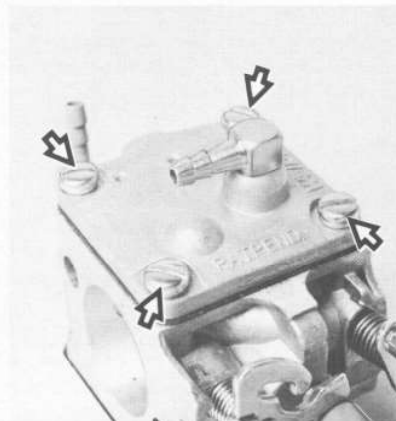
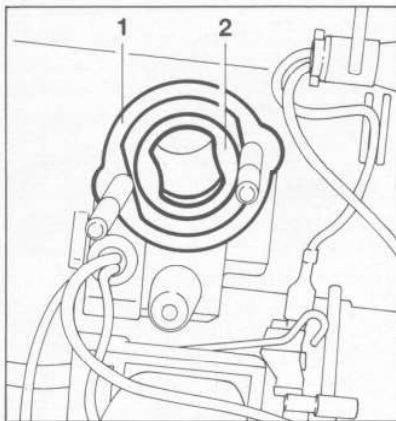

Installation is a reversal of the removal sequence.

**Note:** Check that sleeve (in manifold) and washer are in place before fitting the carburetor in position.

After fitting the carburetor, check that the elbow connector is properly seated in the impulse hose.

Tighten down mounting nuts to 3.5 Nm (2.6 lbf.ft).

- Remove the carburetor  
- see 11.4.

**Note:** It is advisable to check the serviceability of the fuel pump whenever the carburetor is removed for repair.

- Unscrew the fuel pump end cover and remove the gasket and pump diaphragm.

**Note:** The diaphragm and gasket often stick to the cover or carburetor body. If this is the case, take particular care when separating them.

The diaphragms are the most delicate parts of the carburetor. They are subjected to continuous alternating stresses and the material eventually shows signs of fatigue, i.e. the diaphragms distort and swell. Correct operation of the carburetor is no longer possible. Check the gaskets and replace them if they are damaged.

- If the fuel strainer is dirty, use a scribe to pry it out of the carburetor body and then clean it.

**Important:** If the fuel strainer is damaged, fit a new one.

In such a case the fuel pickup body should also be inspected and replaced if necessary - see 11.9.

Top:  
Removing sleeve from stub  
(carburetor with compensator)

Bottom:  
End cover fastening screws  
(carburetor with compensator)

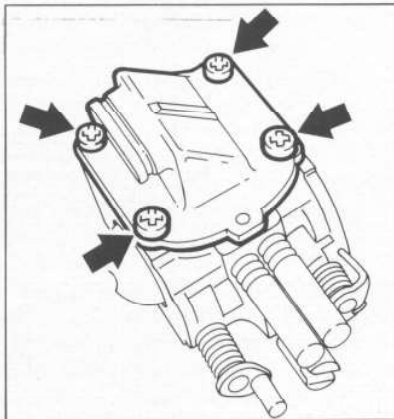
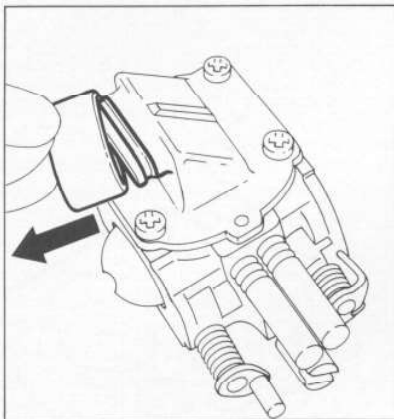

- Pull the sleeve off the compensator's stub.
- To disassemble the carburetor, take out the screws of the metering chamber end cover with compensator and lift away the cover.

Top:  
End cover fastening screws  
(carburetor without compensator)

Bottom:  
Separating gasket and diaphragm

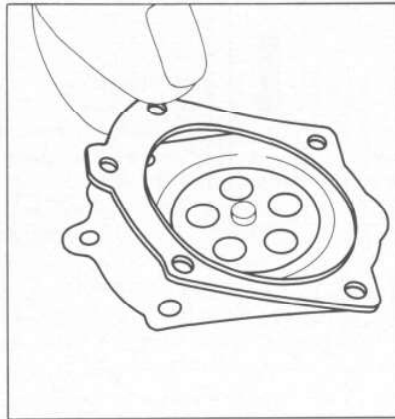
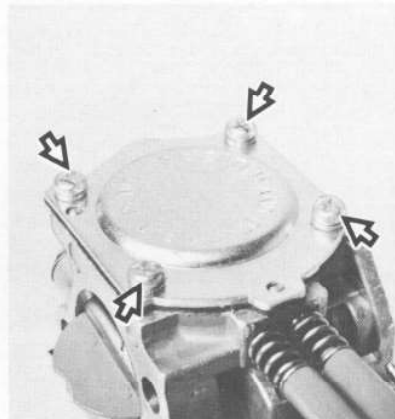

- On carburetors without compensator, unscrew the metering chamber end cover and lift it away.
- Remove the metering diaphragm and gasket from the carburetor body or the cover and separate them carefully.
- Inspect the metering diaphragm and gasket and replace if necessary.

Top:  
Round head screw on control lever spindle

Bottom:  
1 = Spindle  
2 = Inlet control lever  
3 = Helical spring  
4 = Inlet needle

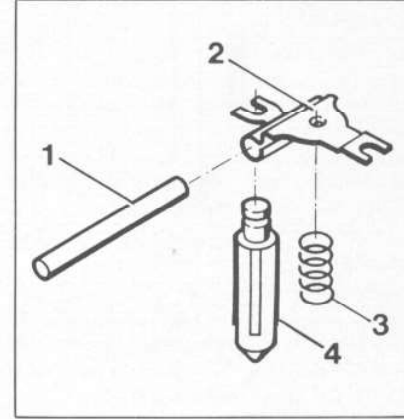
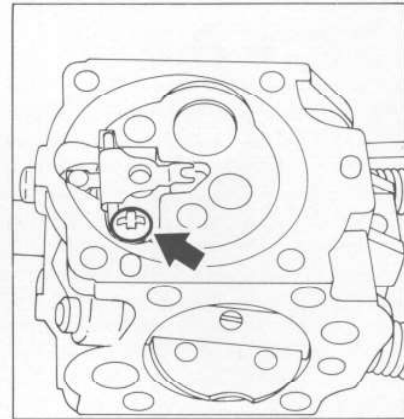

- The inlet needle valve is located in a recess in the metering diaphragm chamber. Take out the round head retaining screw.
- Remove the inlet control lever with spindle, helical spring and inlet needle.

Top:  
Damaged inlet needle

Bottom:  
Pressing out valve jet

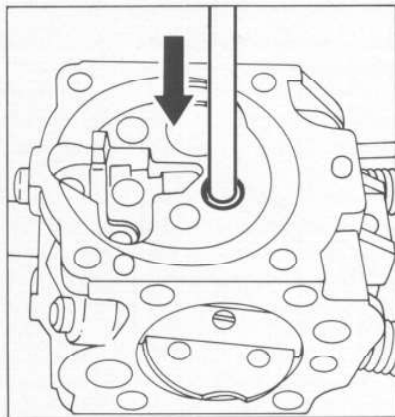
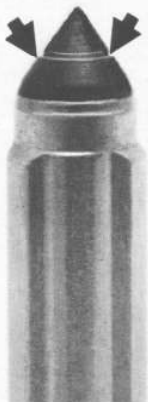

If there is an annular indentation on the sealing cone of the inlet needle, it will be necessary to replace the inlet needle because it will no longer seal properly. This is indicated by constant flooding of the carburetor even though the needle is clean.

- Use a 4 mm (approx. 5/32") dia. drift to press the valve jet out of its seat and wash it in white spirit.

Top:  
Carburetor adjusting screws

Bottom:  
Pressing out fixed jet (066)

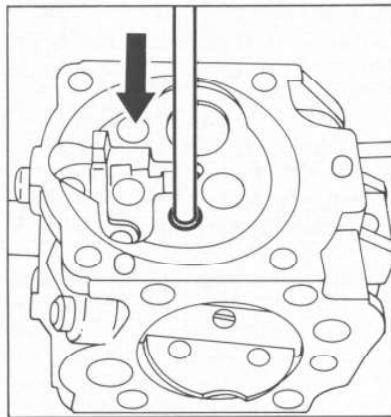
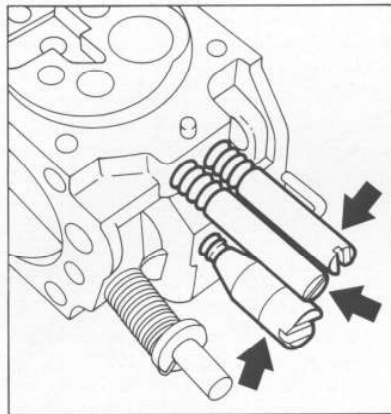

- Remove the carburetor adjusting screws.
- Use a 3 mm (approx. 1/8") dia. drift to press the fixed jet of the 066 out of its seat wash it in white spirit.
- On the 064, use a scriber to pry out the retaining ring. Remove the fixed jet and O-ring.
- Pry the sealing plug out of the metering chamber.

Top:  
Removing fixed jet (064)  
1 = Retaining ring  
2 = Fixed jet  
3 = O-ring

Bottom:  
1 = Semi-fixed jet  
2 = Sealing plug

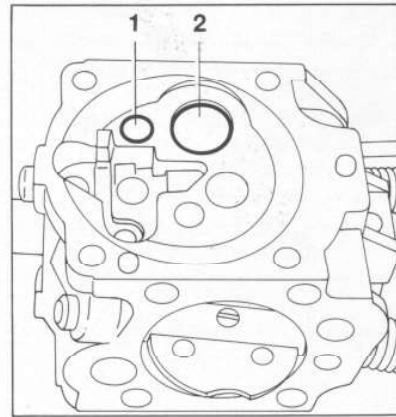
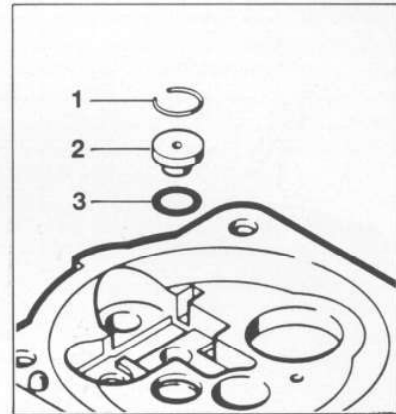

**Caution:** The sealing plug is destroyed during removal. It should, therefore, only be removed if a replacement is available.

Wash the carburetor body and all serviceable parts in fresh white spirit and blow clear with compressed air, paying special attention to the bores and ports.

The carburetor in the 066 is equipped with a semi-fixed jet which cannot be removed. Blow it clear with compressed air.

1 = Valve jet  
2 = Fixed jet (066)

Correct position of inlet control lever

Locating pegs on body

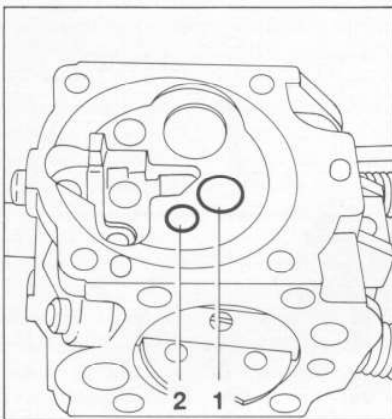

- When inserting the valve jet and fixed jet, make sure they are exactly vertical in their bores. Press the jets home until they are flush with the metering chamber.
- On the 064, fit a new O-ring in the bore for the fixed jet. Press home the fixed jet, small diameter first, and secure it with the retaining ring.

**Note:** The fixed jet "68" (with 0.68 mm orifice) installed in model 064 saws enables the engine to be tuned for optimum performance up to an altitude of approx. 2,000 m (6,500 ft) above sea level. A smaller fixed jet "64" (high altitude jet) can be installed for operation at higher altitudes.

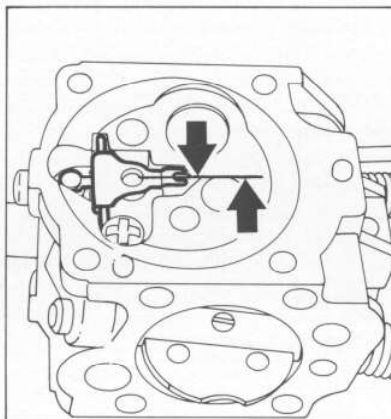

- Fit the inlet needle and the helical spring in their respective bores. Insert spindle in the inlet control lever, engage clevis in annular groove on the head of the inlet needle and tighten down the round head screw. Make sure that the helical spring locates on the control lever's nipple.

**Important:** The upper edge of the inlet control lever must be flush with the metering diaphragm seating face. If necessary, use suitable pliers to carefully bend the lever.

- Check easy action of the inlet control lever.

-

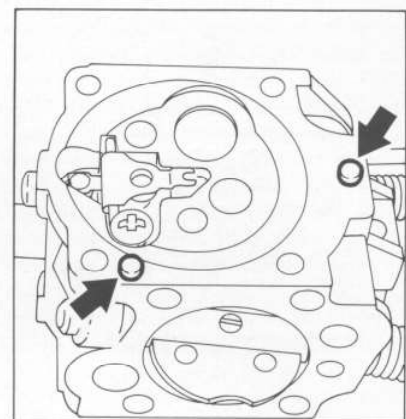

- Fit the gasket, metering diaphragm and end cover. The metering diaphragm and gasket are held in position by the integrally cast pegs on the carburetor body.

**Note:** An end cover with compensator can be installed in place of the normal end cover if the connector stub on the inner filter element is opened up and carefully deburred.

- Insert the fuel strainer at the pump side. Fit the pump diaphragm, gasket and end cover and tighten down securely. The pump diaphragm and gasket are held in position by the integrally cast pegs on the end cover.

- Refit the carburetor adjusting screws.

- Carry out leakage test, see 11.3, after installing the carburetor.

Top:  
Throttle shutter fastening screw

Bottom:  
Withdrawing throttle shaft with pliers

Top:  
Cross recess screw (1) and clip (2)  
on throttle shaft

Bottom:  
Retaining ring on choke shaft

Round notch in choke shutter

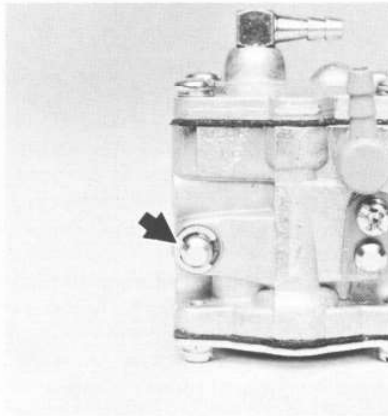
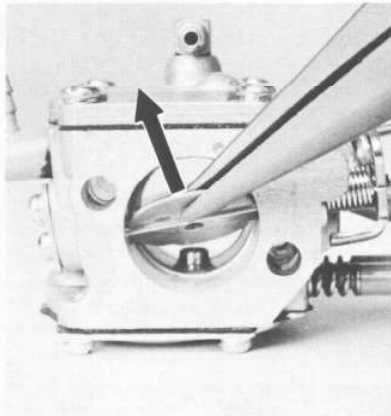
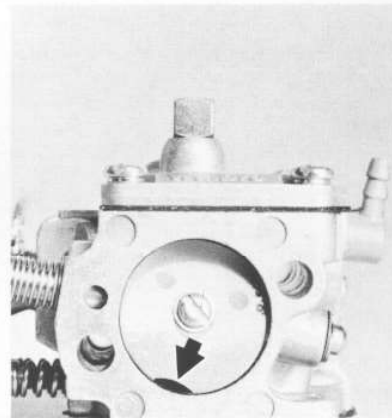
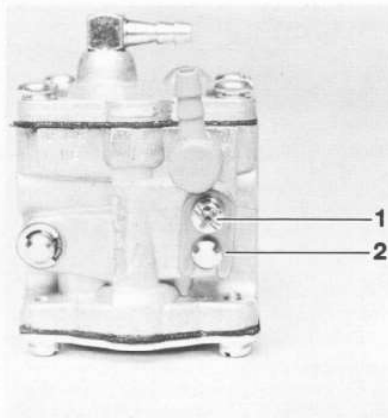
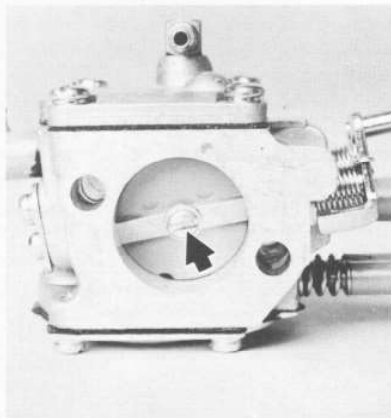

- Pull the throttle shaft or choke shaft out of the carburetor and take off the torsion spring.

Installation is a reversal of the removal sequence.

**Note:** After installing the throttle shaft or choke shaft, check that torsion springs are correctly positioned. The round notch in the throttle and choke shutters must face the metering chamber.

Coat fastening screws of choke and throttle shutters with Loctite, see 12.2, and tighten down securely.

- Install the carburetor - see 11.4.

**Removing the throttle and choke shafts:**

- Take out the fastening screw.
- Use suitable pliers to withdraw the throttle shutter, or take away the choke shutter.

- Unscrew the cross recess screw and remove the clip on the throttle shaft.
- Pry the retaining ring off the choke shaft.

## 11.6 Carburetor Adjustment (Analog Ignition)

Adjusting screws on carburetor  
1 = High speed adjusting screw  
2 = Low speed adjusting screw  
3 = Idle speed adjusting screw

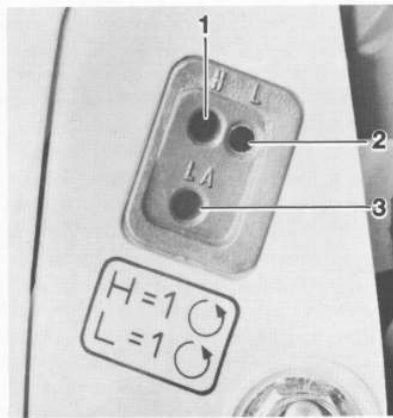

When the engine is tested at the factory the carburetor is set to obtain a slightly richer mixture to provide the cylinder bore and bearings with additional lubricant during the break-in period. This setting should be left as it is for the first three tank fillings. The high speed adjusting screw may then be turned up to 1/4 turn clockwise to obtain a leaner mixture.

**Caution:** The engine's maximum permissible speed with bar and chain must not be exceeded.

If the saw is used at high altitudes (mountains) or near sea level, it may be necessary to alter the carburetor setting slightly. This correction is made at the two adjusting screws (H and L) as follows:

- Turn clockwise for a leaner mixture (at high altitudes).

- Turn counterclockwise for a richer mixture (at sea level).

**Important:** Note that even very slight variations at the adjusting screws produce a noticeable change in engine running behavior.

**Note:** Always make sure that the engine is warm and the air filter clean before carrying out carburetor adjustments.

**Caution:** The setting of the high speed adjusting screw not only affects the engine's performance but also its maximum off-load speed. If the setting is too lean (adjusting screw turned too far clockwise), the maximum permissible engine speed will be exceeded. This can result in damage to the engine being caused by a lack of lubricant and overheating.

Corrections to the high speed adjusting screw may only be carried out if the maximum permissible engine speed of 12,000 rpm (with bar and properly tensioned chain) can be checked with an accurate tachometer.

### Basic setting

If the carburetor has to be adjusted from scratch, carefully screw both adjusting screws clockwise down onto their seats to obtain a starting point for fine tuning.

Then make the following adjustments:

**High speed adjusting screw H:**  
back off 1 full turn

**Low speed adjusting screw L:**  
back off 1 full turn

The saw must be run with the basic carburetor setting (H = 1, L = 1) if an accurate tachometer is not available for checking the engine's maximum speed.

### Notes for adjustment of idle speed

#### Engine stops while idling:

- Turn idle speed adjusting screw clockwise until the chain begins to run.
- Then turn it back one quarter turn.

#### Chain runs while engine is idling

- Turn the idle speed adjusting screw counterclockwise until the chain stops running.
- Then turn it about another quarter turn in the same direction.

## 11.7 Carburetor Adjustment (Digital Ignition)

Regulating low speed adjusting screw

- 1 = High speed adjusting screw
- 2 = LED (066 only)
- 3 = Low speed adjusting screw
- 4 = Idle speed adjusting screw

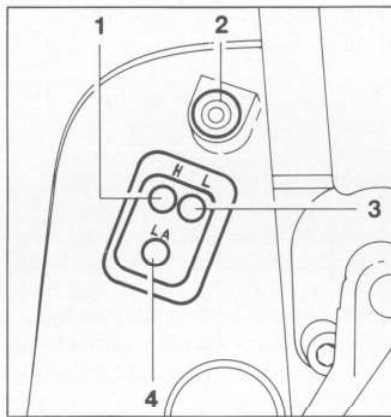
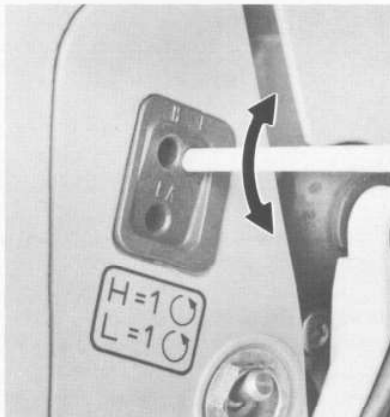

### Erratic idling behavior, poor acceleration

- Idle setting too lean.
- Turn the low speed adjusting screw counterclockwise until the engine runs and accelerates smoothly.

### Exhaust smokes at idle speed

- Idle setting too rich.
- Turn the low speed adjusting screw clockwise until the engine speed drops.
- Turn screw back one quarter turn.
- Check that the engine accelerates smoothly when the throttle is opened.

**Note:** A correction at the low speed adjusting screw usually necessitates a change in the setting of the idle speed adjusting screw.

Machines with digital ignition have an electronic maximum speed governor. Adjustment of the engine's maximum speed is possible, but not beyond the preset limit.

An excessively lean mixture does not produce an increase in power - it only increases the risk of engine damage.

The light emitting diode (LED) aids carburetor adjustment.

### Standard setting

To adjust the carburetor without a tachometer or if the LED fails, carefully screw both adjusting screws down onto their seats.

Then make the following adjustments:

**High speed adjusting screw H:**  
back off 1 full turn

**Low speed adjusting screw L:**  
back off 1 full turn

**Note:** This is the optimum setting of the adjusting screws for normal operation at an altitude of about 300 m (1,000 ft) above sea level.

If the LED has failed and the adjustment has to be made without a tachometer, do not turn the high speed adjusting screw beyond this standard setting, i.e. leaner.

### Corrections to high speed adjusting screw with tachometer (064)

If it is necessary to alter the setting of the high speed adjusting screw, carry out the adjustment as follows using an accurate tachometer:

- Carefully screw the high speed adjusting screw down onto its seat.
- From this position, back off the high speed adjusting screw exactly two full turns.
- Start the engine and allow it to warm up.
- Adjust idle speed correctly.

## 11.8 Tank Vent

- Run engine at a full throttle and slowly rotate high speed adjusting clockwise until tachometer indicates 12,000 rpm.
- Allow engine to return to idle speed.
- Rotate high speed adjusting screw another half turn clockwise.

**Note:** This is the optimum setting of the high speed adjusting screw under the barometric pressure and climatic conditions at the operating site.

With the carburetor adjusted in this way the engine speed at full throttle may reach the cut-off range of the governor. As the tachometer uses the firing pulse to measure engine speed, it can, at full throttle, indicate a speed which is much lower than the true maximum rpm. This is due to the fact that the engine does not fire on every revolution when it is running within the operating range of the electronic speed governor.

**Note (064 only):** If the amount of adjustment travel left on the high speed adjusting screw, after setting it to 12,000 rpm, is much less than one half turn, the fixed jet "64" can be installed in place of fixed jet "68" - see 11.5.

#### Corrections to high speed adjusting screw with LED (066)

- Adjust idle speed correctly.
- Carefully screw the high speed adjusting screw down onto its seat.
- From this position, back off the high speed adjusting screw exactly two full turns.
- Start the engine and allow it to warm up.
- Run engine at a full throttle and slowly rotate high speed adjusting clockwise until the LED lights up.
- Allow engine to return to idle speed.
- Rotate high speed adjusting screw another half turn clockwise.

**Note:** This adjustment can be carried out with a tachometer if the LED fails.

Prying vent connector off stub

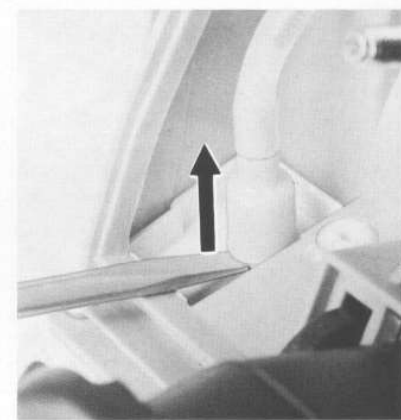

Correct operation of the carburetor is only possible if atmospheric pressure and internal fuel tank pressure are equal at all times. This is ensured by the tank vent.

**Important:** In the event of trouble with the carburetor or the fuel supply system, always check and clean the tank vent.

- Remove the air filter - see 11.1.
- Remove the vent connector from the stub on the tank housing.
- Pull the vent hose out of the bore in the carburetor box.

11.9 Fuel Filter and Fuel Hose

Top:  
 1 = Grub screw  
 2 = Vent hose  
 3 = Vent connector

Bottom:  
 Correctly positioned grub screws  
 a = 12-15 mm (approx. 1/2")

Fuel filler cap

Top:  
 Assembly hook 5910 893 8800

Bottom:  
 Withdrawing the pickup body

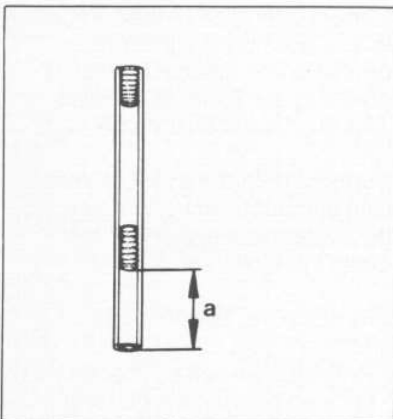
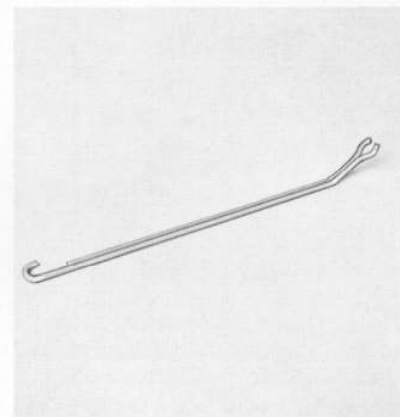
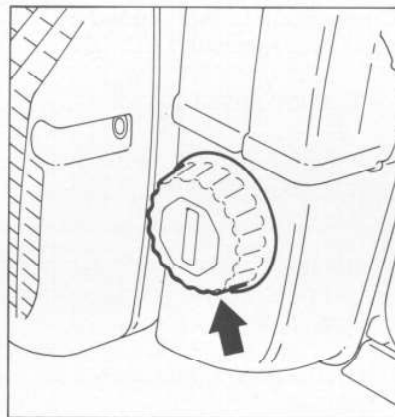
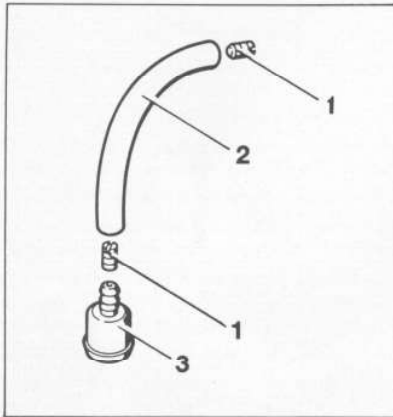

The diaphragm pump draws fuel out of the tank and into the carburetor via the fuel hose. Any impurities mixed with the fuel are retained by the pickup body (filter). The fine pores of the filter eventually become clogged with minute particles of dirt. This restricts the passage of fuel and results in fuel starvation.

**Important:** In the event of trouble with the fuel supply system, always check the fuel tank and the pickup body first. Clean the fuel tank if necessary.

**To clean the fuel tank:**

- Unscrew the filler cap and drain the tank.
- Pour a small amount of clean gasoline into the tank.
- Close the tank and shake the saw vigorously.
- Open the tank again and drain it.

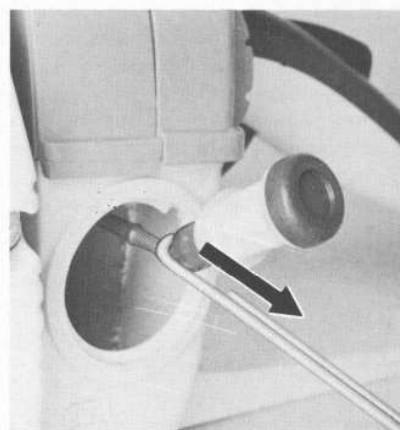

**To remove and install the pickup body:**

- Use the assembly hook to pull the pickup body out through the filler opening.

**Note:** Do not stretch the intake hose too much while pulling out the pickup body.

- Pull the pickup body off the fuel hose.
- Remove cap from pickup body and take out the weight.

- Pull the vent hose off the vent connector.
- Use a drift to push the grub screws out of the hose.
- Wash all parts in fresh white spirit and blow out with compressed air.

Install the tank vent by reversing the disassembly sequence.

**Note:** Use a drift to position the grub screws in the vent hose as shown in the drawing.

11.10 Tank Housing

Top:  
Removing pickup body

Bottom:  
1 = Cap  
2 = Weight  
3 = Filter  
4 = Pickup body  
5 = Intake hose

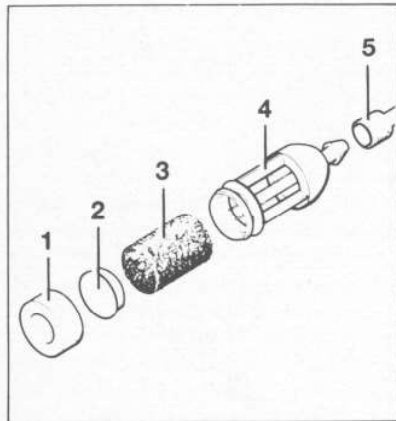
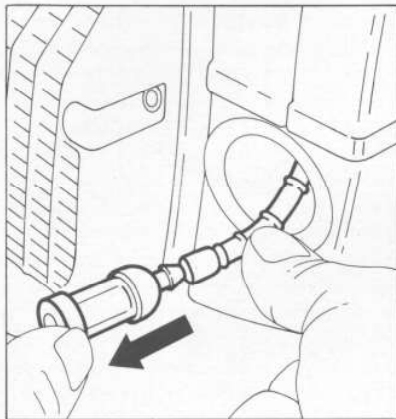

Removing intake hose from tank housing

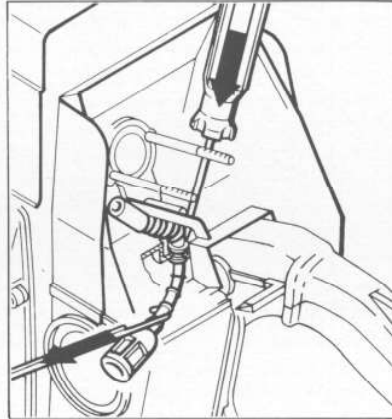

To remove the intake hose:

- Remove the carburetor - see 1 1.4.
- Coat the flange of the intake hose with a little oil.
- Use the assembly hook to reach through the filler opening and catch the intake hose above the pickup body and, at the same time, use a blunt screwdriver carefully push the hose into the tank housing.
- Remove the intake hose and pickup body from the tank housing.
- Pull the pickup body off the intake hose.

Installation is a reversal of the removal sequence.

**Note:** Coat the hose flange with a little oil to simplify installation.

Top:  
Front handle mounting screws on side of tank housing

Bottom:  
1 = Washer  
2 = Sleeve

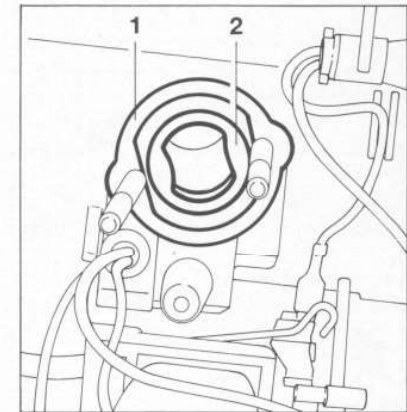
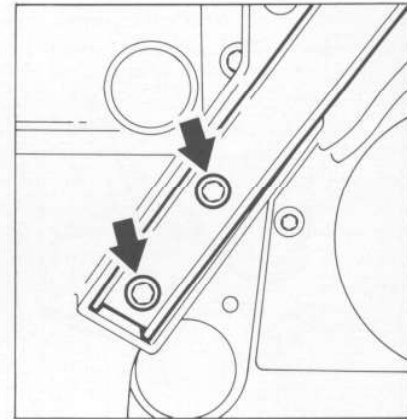

- Drain the tank housing.
- Remove the shroud - see 3.2.
- Remove the fan housing - see 5.1.5.
- Remove mounting screws at side and underside of front handle. Lift away the handle.
- Note:** To remove front handle on machines with handle heating see 9.4.
- Remove the carburetor - see 11.4.
- Pull the washer off the studs and remove the sleeve from the manifold.

**Caution:** The fine mesh strainer on the pickup body must not be damaged. It can be washed in white spirit.

**Note:** It is not advisable to clean the filter - always fit a new one.

Installation is a reversal of the removal sequence.

**Important:** The foam filter must be fitted without being creased or twisted in any way.

Top:  
 1 = Connector for LED  
 2 = Ground wire  
 3 = Short circuit wire

Bottom:  
 Plugs in annular buffers

Top:  
 1 = Mounting screw on upper annular buffer  
 2 = Inner side plate  
 3 = Chain catcher  
 4 = Plug

Bottom:  
 Pushing out manifold flange

Top:  
 1 = Grommet  
 2 = Ground, short circuit and LED wires  
 3 = Nipple  
 4 = Impulse hose

Bottom:  
 Ring

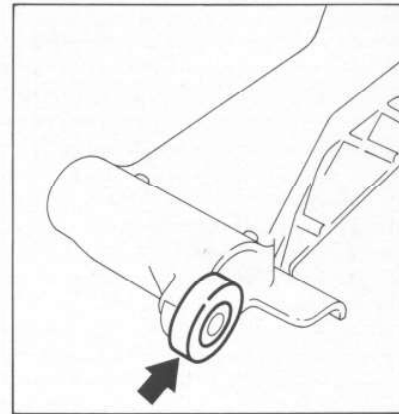
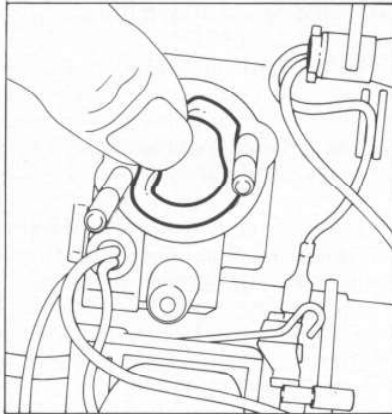
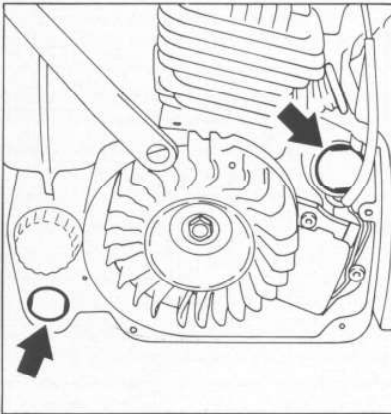
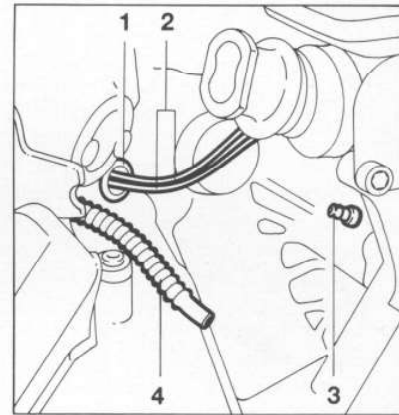
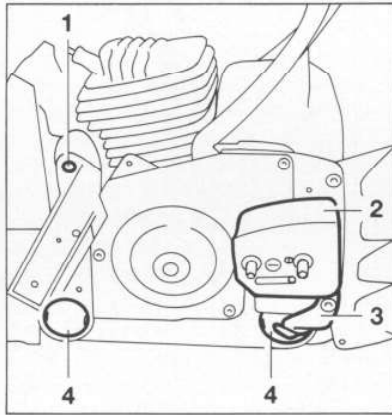
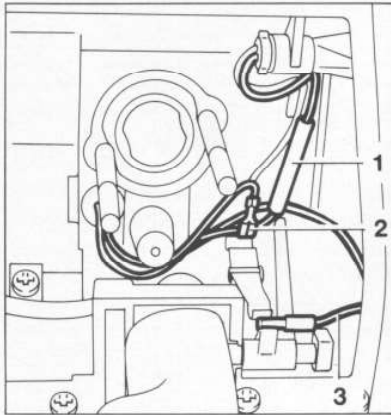

- Disconnect ground wire from contact spring and pry contact sleeve of short circuit out of its seat.

**Note:** On 066, disconnect wire to LED at connector.

- Pry the plugs out of the annular buffers at the ignition side.
- Remove mounting screws from annular buffers.

- Remove the inner side plate and chain catcher.

- Pry the plugs out of the annular buffers and remove the mounting screws.

- Remove screw from the upper annular buffer.

- Pull the tank housing forward and push the manifold flange out of the tank housing intake opening at the same time.

- Pull the impulse hose off the nipple. Pry the grommet out of the housing and pull out the short circuit and ground wires.

- Remove the ring from the tank housing.

**Note:** If a screw thread is stripped in one of the mounting holes for special self-threading screws, the tank housing can be repaired by installing a thread insert. The stripped thread must be drilled out to a diameter of 8.5 mm and a depth of 15 mm (approx. 9/16").

11.11 Carburetor Box

Top:  
Hole size  
a = 8.5 mm dia.  
b = 15 mm (approx. 9/16")

Bottom:  
Installing thread insert 9799 543 0900

Carburetor box mounting screws

Top:  
Modified seat for manifold on  
carburetor box

Bottom:  
Groove in tank housing

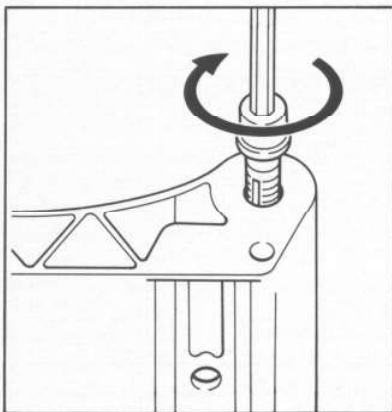
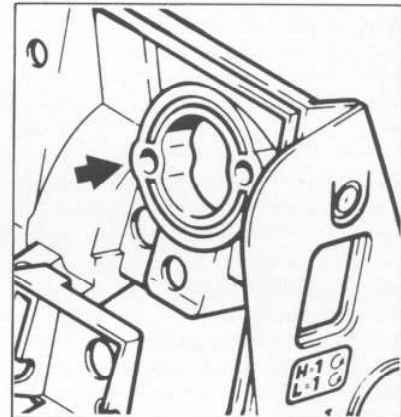
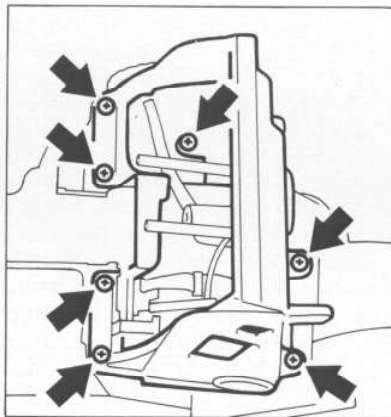
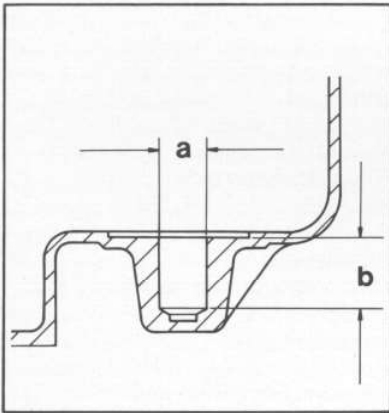

Tank housings and carburetor boxes from machine number X 17 861 749 are screwed together instead of welded. This enables the carburetor box to be replaced as a separate unit.

- Remove the tank housing - see 11.10.
- Take out the carburetor box mounting screws.
- Carefully heat the carburetor box mating surface (e.g. with a hair dryer) and then pull the carburetor box off the tank housing.

**Note:** The carburetor box has been modified in the manifold seating area. For this reason the manifold, the sleeve in the manifold and the washer have to be replaced along with the carburetor box - see 4.2 and 4.3.2.

**Important:** Do not exceed the specified hole depth of 15 mm.

Fit M6 x 10 screw with washer in the thread insert.

Screw the thread insert into the tank housing. An M6 x 18 pan head screw must then be used in place of the special self-threading screw.

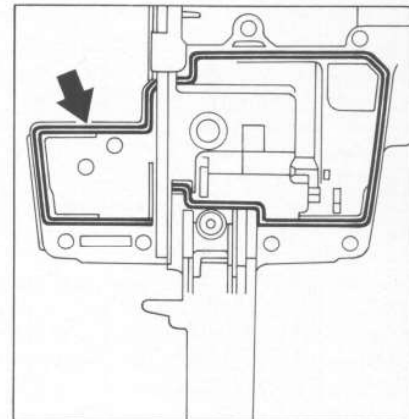

- Thoroughly clean the groove in the tank housing and fill it with insulating paste - see 12.2.
- Fit the carburetor box in position, insert screws and tighten them down firmly.
- If insulating paste oozes out of the joint, wait a few minutes and then remove the excess.
- Fit the tank housing - see 11.10.

## 12. Special Servicing Tools and Aids

## 12.1 Special Servicing Tools

No.	Part Name	Part No.	Application
1	Locking strip	0000 893 5902	Blocking crankshaft
2	Press sleeve	1119 893 2401	Fitting oil seal (clutch side)
3	Press sleeve	1128 890 3900	Fitting oil seal (ignition side)
4	Assembly sleeve	1122 893 4600	Protects oil seal at clutch side
5	Puller	0000 890 4400	Removing oil seals
6	- Jaws (No. 6)	0000 893 3711	
7	Puller	1110 890 4500	Removing flywheel
8	Crimping tool	5910 890 8210	Attaching connectors to electric wires
9	Assembly drift	1108 893 4700	Fitting piston pin
10	Clamping strap	0000 893 2600	Compressing piston rings
11	Wooden assembly block	1108 893 4800	Fitting piston
12	Carburetor and crankcase tester	1106 850 2905	Testing carburetor and crankcase for leaks
13	Vacuum pump	0000 850 3500	Testing crankcase for leaks
14	- Nipple	0000 855 9200	
15	- Fuel line	1110 141 8600	
16	Sealing plate	0000 855 8106	Sealing exhaust port for leakage test
17	Test flange	1113 850 4200	For leakage test
18	Setting gauge	1111 890 6400	Setting air gap between ignition module and flywheel
19	Socket, 13 mm	5910 893 5608	Crankshaft nut
20	Socket, 19 mm	5910 893 5612	
21	Torque wrench	5910 890 0300	
22	Torque wrench	5910 890 0310	
23	Screwdriver bit I-5x150	0812 542 2104	For spline screws
24	Assembly hook	5910 893 8800	Removing pickup bodies
25	Installing tool	5910 890 2212	Fitting hookless snap rings in piston
26	Press arbor	1122 893 7200	Removing crankshaft bearing at ignition side
27	Press arbor	1119 893 7200	Removing and installing crankshaft bearings
28	Assembly hook	5910 890 2800	Detaching springs from clutch shoes
29	Installing tool	0000 890 2201	Flaring rope guide bush
30	Assembly tube	1117 890 0900	Attaching the brake spring
31	Centering tool	1118 893 3500	Centering heating generator
32	Service tool AS	5910 007 2205	Removing crankshaft (clutch side)
33	Service tool ZS	5910 007 2220	Removing crankshaft (ignition side)
34	T-handle screwdriver QI-5 x 150	5910 890 2400	For all IS screws
35	Stud puller MS	5910 893 0501	Removing bar mounting studs
36	Puller	1107 890 4500	Removing generator centering tool
37	Press disk	5910 893 5100	Installing rewind spring

## 12.2 Servicing Aids

No.	Part Name	Part No.	Application
1	Lubricating grease	0781 120 1111	Oil seals, oil pump drive, chain sprocket bearing
2	Medium-strength threadlocking fluid (Loctite 242)	0786 111 1101	Securing screws, see 1.5. Anchor pin for brake spring
3	High-strength threadlocking fluid (Loctite 270)	0786 111 1109	Fastening screws on choke and throttle shutters
4	High-strength threadlocking fluid (Loctite 648)	0786 111 1117	Securing screws, see 1.5.
5	Standard commercial, solvent-based degreasant containing no CFCs		Cleaning crankshaft stub
6	Sealant	0783 810 1101	Manifold, crankcase gasket
7	STIHL special lubricant	0781 417 1315	Bearing bore in rope rotor, rewind spring in starter
8	Ignition lead HTR, 10 m (33')	0000 930 2251	
9	Molykote grease		Sliding and bearing points of brake band
10	Graphite grease		Pawl guide pegs
11	Electrician's repair kit	0000 007 1013	
12	Insulating paste (Elastosil)	0783 820 0110	Sealing joint between carburetor